



# MANUEL D'INSTRUCTIONS INSTRUCTION MANUAL

---

**Florence Solarium 12 Pl. X 12 Pl. - Toit d'Acier**  
**Florence Solarium 12 FT. X 12 FT. - Metal Roof**

---

sku: 41212MR-GP-12		
sku: 41212MR-GP-32		
sku: 41212MR-GP-42		

---

**DE NE PAS DÉTRUIRE LES BOITES AVANT FINIR L'INSTALLATION AU COMPLET  
POUR LA RÉFÉRENCE FUTURE, PRENEZ DES PHOTOS DE TOUS LES SIX COTÉS DE  
CHACUNI DES BOITES À LA RÉCEPTION DU PRODUIT.**

**SVP, VÉRIFIEZ LE CONTENU DE CHAQUE BOITE VS LA LISTE DES PIÈCES DÉTAILLÉE**

**12pi x 12pi / 3.66m x 3.66m Meters Solarium**

**LES INSTRUCTIONS D'INSTALLATION**

**IMPORTANT: RETENIR POUR LA FUTURE RÉFÉRENCE, LIRE ATTENTIVEMENT**

Consultez votre autorité locale / les codes municipaux locaux concernant l'installation de structures temporaires avant l'achat ou l'assemblage. Certaines juridictions peuvent exiger des permis pour, ou réglementer autrement, l'installation et l'utilisation.

Pour l'assistance de l'assemblage, d'installation, des pièces en particulier, ou service à la clientèle, veuillez contacter Gazebo Penguin au numéro de téléphone mentionné mi-bas : (français, anglais, lun. à ven. de 8 du matin à 4 après-midi est) :

**Montréal: (514) 276-3485**

**Canada et États-Unis: 1-800-737-7174**

**ATTENTION:**

- Pour une utilisation à l'extérieur.
- La neige doit être nettoyée en tout le temps, de ne pas laisser s'accumuler.
- Retenir votre **preuve d'achat** pour la garantie. Veuillez **garder les boîtes** jusqu'à d'avoir fini l'installation correctement au complet.
- D'assemblage peut durer plus que 4 heures et l'exige d'avoir au moins 3 personnes.



**AVANT ASSEMBLAGE:**

- Veuillez ne pas détruire les boîtes avant d'avoir fini complètement assemblage.
- La fondation doit être sous le niveau de sol, plat et solide, comme du béton ou de l'asphalte.
- Tenez à l'écart des lignes électriques aériennes, des branches d'arbres et d'autres structures.
- Vérifiez s'il y a des tuyaux ou des fils souterrains si le creusement ou le forage est nécessaire.
- Ne pas installer à proximité des lignes de toit ou d'autres structures qui pourraient jeter de la neige, de la glace ou une pluie excessive sur le toit.
- Assemblez la structure près du point final d'utilisation la plus proche possible.
- Il est recommandé de porter des gants de sécurité, des lunettes de sécurité et des casques de protection pour l'installation.
- Ne vous suspendez pas, ne grimpez pas et ne vous tenez pas debout sur la structure ou le toit.
- Avant le montage, lisez les instructions et vérifiez que toutes les pièces sont présentes dans les boîtes. S'il manque des pièces, svp, contactez notre département de garantie.
- Un escabeau de 6 pieds (1,8 m), un tournevis Phillips, un ruban à mesurer, un niveau, un maillet et une bâche sur laquelle placer les pièces seront nécessaires pour l'assemblage (non inclus).
- Enlevez le film protecteur supérieur des panneaux de toit avant l'assemblage; NE PAS retirer le film protecteur inférieur avant d'être prêt à insérer les panneaux de toit, afin d'identifier le côté supérieur.

**INSTRUCTION D'ANCRAGE:**

- Un ancrage adéquat du cadre à la base et au mur est nécessaire pour la sécurité.
- Une structure non solidement ancrée a un risque de s'envoler lors de vents violents causant des dommages et des risques pour la sécurité.
- Le matériel et les outils requis pour l'ancrage varient en fonction de l'emplacement d'installation et ne sont pas fournis.
- Veuillez vérifier auprès de votre quincaillerie locale les ancrages appropriés à votre surface.
- Ne pas ancrer aux pavés / dalles de chaussée car ils ne constituent pas une fondation solide.

**SOIN ET MAINTENANCE:**

- En cas de pièce défectueuse ou endommagée, ou pour toute autre question concernant le produit, veuillez contacter directement le fabricant.
- Veuillez avoir la liste des pièces et les numéros de pièces à portée de main lors de la commande ou de la demande de pièces de rechange.









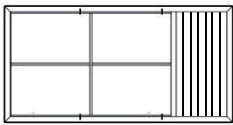

**PANNEAUX DE TOIT:**

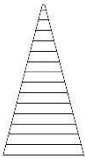
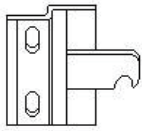
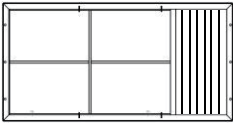
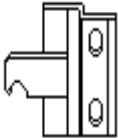

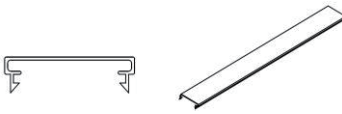





- Nettoyez doucement avec une solution savonneuse écologique et de l'eau à l'aide d'une éponge.
- N'utilisez pas de matériaux abrasifs, de brosses métalliques, de produits chimiques, de nettoyeurs puissants ou d'eau de javel.
- Rincer à l'aide d'un tuyau d'arrosage et sécher à l'air. S'il est retiré, assurez-vous qu'il est complètement sec avant le stockage.
- N'utilisez pas de nettoyeur haute pression.

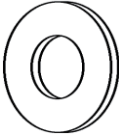
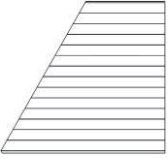
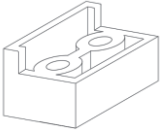

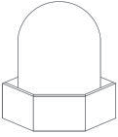
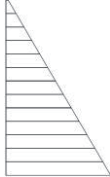

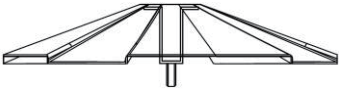

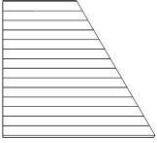

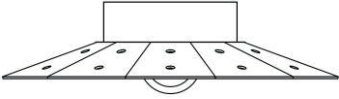
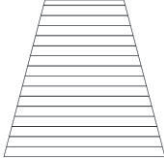
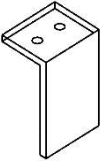

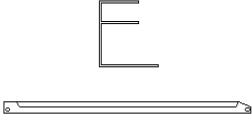
**STRUCTURE:**

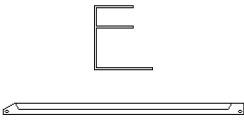
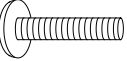
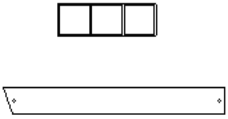

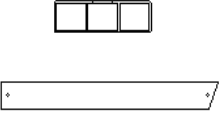

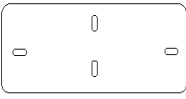
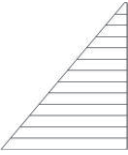

- Nettoyez doucement avec une solution savonneuse écologique et de l'eau à l'aide d'une éponge.
- N'utilisez pas de matériaux abrasifs, de brosses métalliques, de produits chimiques, de nettoyeurs puissants ou d'eau de javel.
- Rincer à l'aide d'un tuyau d'arrosage et sécher à l'air. N'utilisez pas de nettoyeur haute pression.
- S'il y a des imperfections voir le numéro de pièce de la peinture dans la liste des pièces pour obtenir une peinture de retouche correspondante.

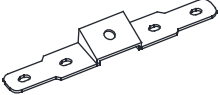
## 12 x 12 Solarium

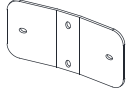
DESCRIPTION	EMBALLE DANS LA BOITE	QUANTITE	SCHEMA	DESCRIPTION	EMBALLE DANS LA BOITE	QUANTITE	SCHEMA
23-086 CADRE REGULIER A	3	4		08-132 CADRE DE PORTE D	3	1	
	4	4			4	1	
17-054 PANNEAU DE TOIT Aa	1	4		08-165 LOQUET DE PORTE Dd-R	5	2	
23-087 CADRE ADJACENT (trous additionnels) B	3	1		08-169 LOQUET DE PORTE Dd-L	5	2	
	4	1					
25-114 VIS M6*16 Bb	5	108		08-133 PIECE DE CONNEXION 78.9" E	5	8	
23-309 PORTE COULISSANTE C	3	1		17-043 CHEVRON 89.9" K	5	8	
	4	1					
25-115 VIS M6*73 Cc	5	12		08-136 RAIL DE PORTE 81.1" F	5	2	
25-117 ECROU M5*60 Cc-2	5	12		08-137 RAIL DE PORTE 81.1" G	5	2	

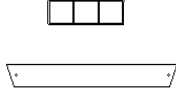

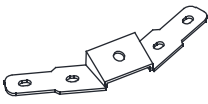





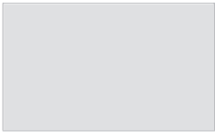
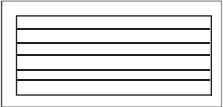

DESCRIPTION	EMBALLÉ DANS LA BOÎTE	QUANTITÉ	SCHEMA	DESCRIPTION	EMBALLÉ DANS LA BOÎTE	QUANTITÉ	SCHEMA
08-187 RONDELLE Gg	5	57		17-061 PANNEAU DE TOIT Kk	2	4	
08-138 BUTOIR PORTE H	5	4		17-044 CHEVRON 78.9" L	5	4	
08-189 ECROU Hh	5	1		17-057 PANNEAU DE TOIT LI	2	4	
08-139 PIECE DE CONNEXION 78.9" I	5	8		08-143 CAPUCHON EXTERIEUR M	5	1	
17-049 BARRE DE TOIT 89.9" O	5	8		17-058 PANNEAU DE TOIT Mm	2	4	
08-140 PIECE DE CONNEXION 78.9" J	5	8		08-144 CAPUCHON INTERIEUR N	5	1	
17-055 PANNEAU DE TOIT Jj	1	4		08-134 CAPUCHON RAIL DE PORTE SUPERIEUR Nn	5	4	

DESCRIPTION	EMBALLÉ DANS LA BOÎTE	QUANTITÉ	SCHEMA	DESCRIPTION	EMBALLÉ DANS LA BOÎTE	QUANTITÉ	SCHEMA
17-050 BARRE DE TOIT 78.5" O1	5	4		17-045 BARRE DE FINITION 45.2" U	5	4	
08-135 VIS Oo	5	4		17-071 BARRE DE FINITION 45.2" U1	5	4	
25-116 VIS M6X36 Oo1	5	50		17-047 BARRE DE SOLIDIFICATION 20.8" V	5	4	
17-051 BARRE DE RECOUVREMENT P	5	8		17-071 BARRE DE SOLIDIFICATION 20.8" V1	5	4	
23-003 BARRE DE RECOUVREMENT P-1	5	4		25-118 VIS M5x15 Ww	5	12	
18-067 SUPPORT DE BARRE SOLIDIFIANTE Pp	5	4		17-060 PANNEAU DE TOIT Y	2	4	
17-053 EMBOUT R	5	4		08-156 VIS M5*20 Z	5	48	
17-046 BARRE DE FINITION S	5	4		15-125 ANGLE EN ACIER Z2	5	4	

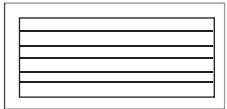
DESCRIPTION	EMBALLÉ DANS LA BOÎTE	QUANTITÉ	SCHEMA	DESCRIPTION	EMBALLÉ DANS LA BOÎTE	QUANTITÉ	SCHEMA
23-004 SUPPORT DE BARRE SOLIDIFIANTE Pp-1	5	8		23-005 EMBOUT R1	5	8	
17-048 BARRE DE SOLIDIFICATION T	5	4		23-215 Clé Hexagonale QQ	5	1	
15-124 ANGLE EN ACIER Z1	5	8		23-223 Clé Hexagonale RR	5	1	

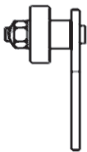
**\* PAS INCLUS DANS LA BOITE**

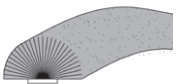
DESCRIPTION	COLOUR	# DE PIÈCE
PEINTURE À SPRAY	SABLE	11-699
STYLO À PEINTURE		18-245

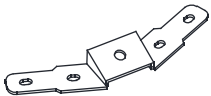
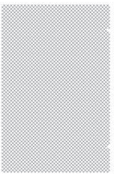
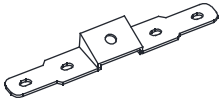
<b>PIÈCES DE REMPLACEMENT DISPONIBLES</b>			
DESCRIPTION	DESSIN	DESCRIPTION	DESSIN
08-219 FENÊTRE PVC (avec cadre)		85-417-S ÉCLISSE POUR MOUSTIQUAIRE	
10-493 FENÊTRE PVC (matériel seulement)		23-090 PANNEAU ACIER DU BAS (pour murs)	
85-417-P ÉCLISSE POUR FENÊTRE PVC		23-091 PANNEAU ACIER DU BAS (pour portes)	
15-123 GOUPILLE POUR FENÊTRE PVC		15-097 ROULEAU DE PORTE	
13-033 FENÊTRE PC (pour porte)		10-458 COUPE-FROID DE REPLACEMENT	
12-046 MOUSTIQUAIRE (avec cadre)		15-124 ANGLE EN ACIER Z1	
85-014 MOUSTIQUAIRE (sans cadre)		15-125 ANGLE EN ACIER Z2	
<b>*PAS INCLUS DANS LA BOITE</b>			
<b>DESCRIPTION</b>	<b>COULEUR</b>	<b># DE PIÈCE</b>	
PEINTURE À SPRAY	SABLE	11-699	
STYLO À PEINTURE		18-245	

**Les dimensions sont approximatives.**

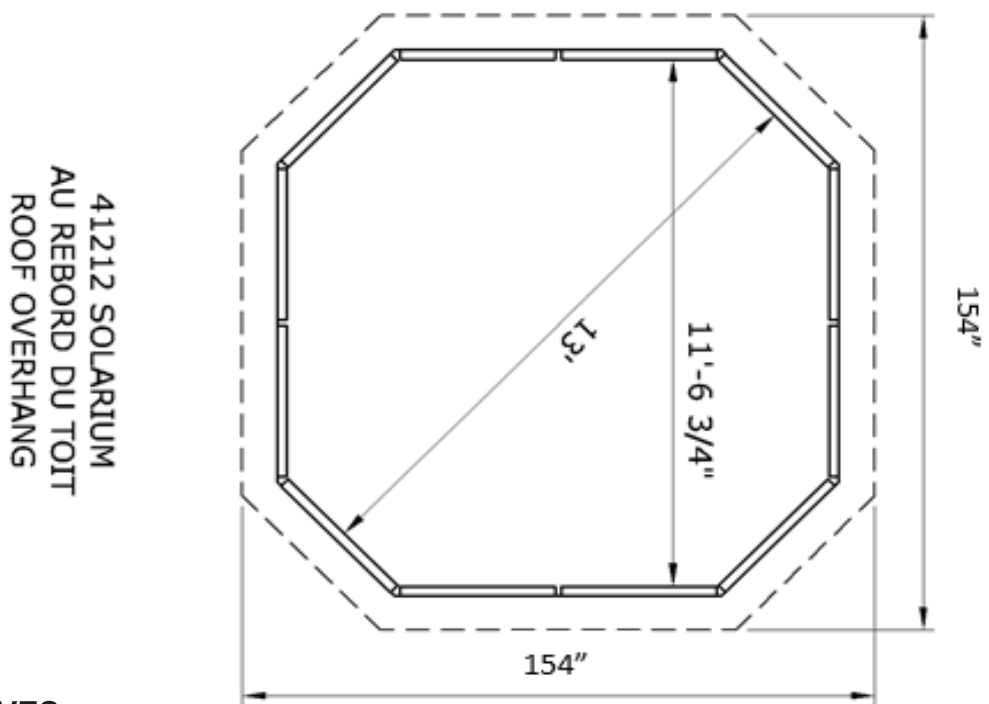
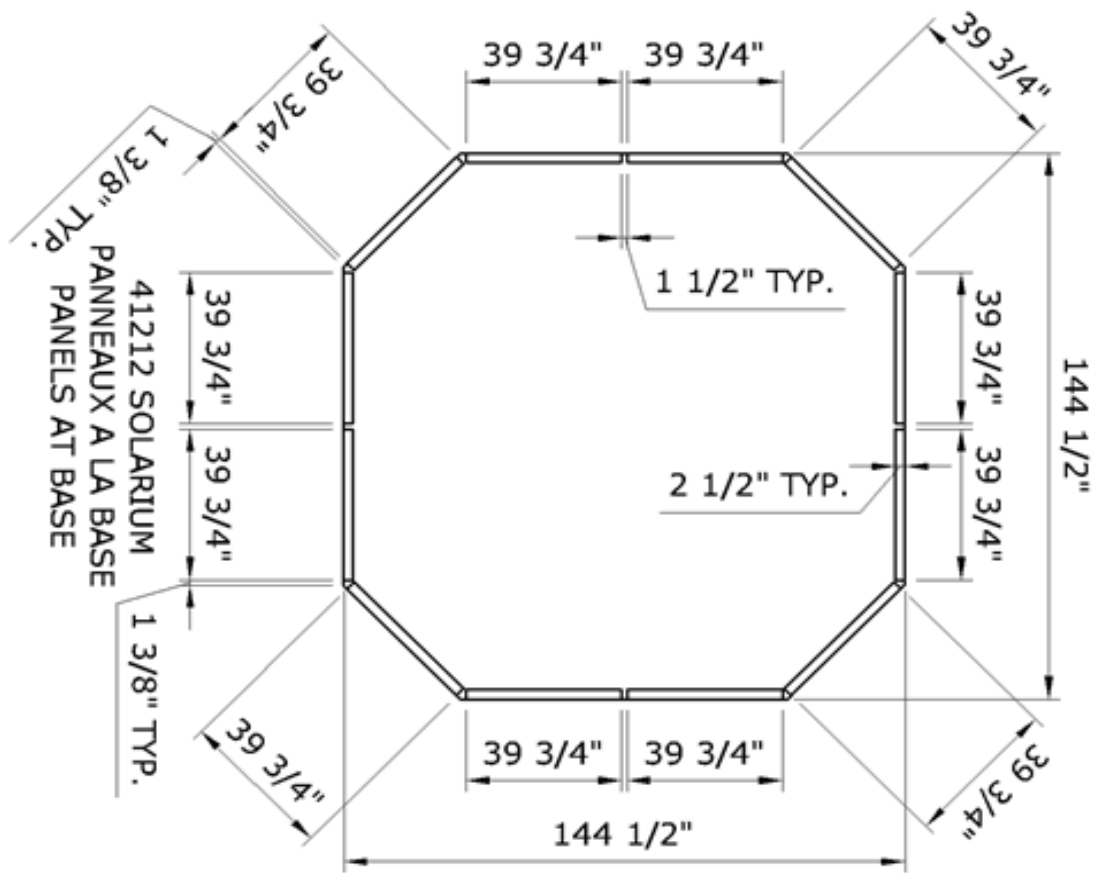

**APPROXIMATIVES.**

## Avant d'assembler le Solarium

- Ne détruisez pas les boîtes tant qu'elles ne sont pas complètement assemblées.
- Pour référence future, prenez des photos des six côtés de chaque boîte dès réception.
- Veuillez comparer chaque boîte à la liste des pièces.

Outils nécessaires :

- Escabeau 6'-8
- Tournevis Phillips #2, Tournevis Robertson #2 (non fourni)
- Maillet en caoutchouc
- Diverses limes
- Perceuse
- Mèche 1/8" pour les trous pilotes

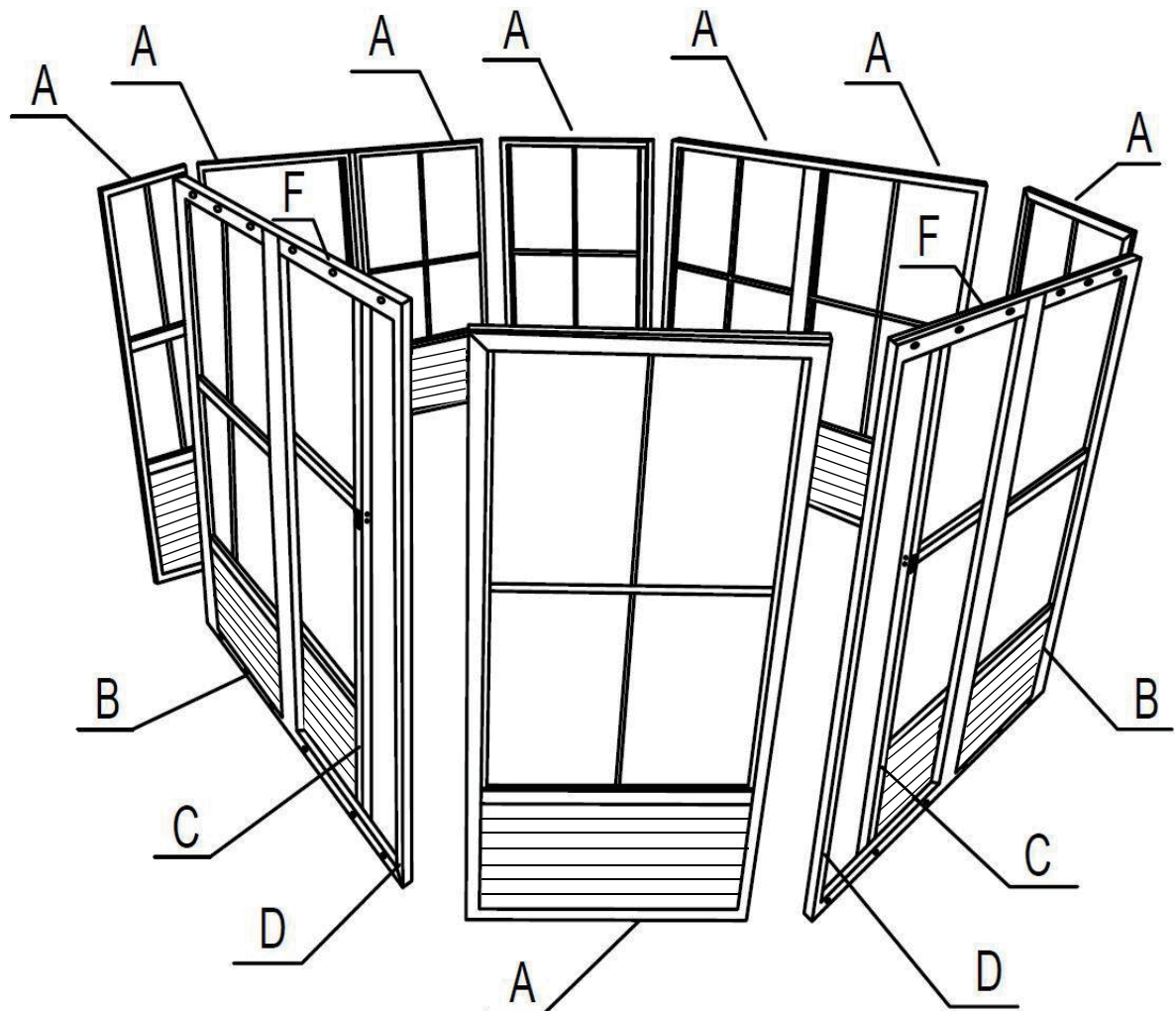

Selon l'emplacement, décidez où vous souhaitez placer les deux (2) panneaux de portes qui peuvent coulisser vers la gauche ou la droite, selon votre choix.

## Étape 1:

1. Levez deux cadres (A), glissez de haut en bas et fixez les panneaux ensemble à l'aide de deux pièces de connexion (I, J).
2. Montez ensuite le cadre à côté de la porte (B) et à l'aide de la pièce de raccordement (E), connectez-le au cadre de porte A précédemment défini, comme illustré ci-dessous. De même, installez un cadre de porte (D) en plaçant le cadre de porte à gauche ou à droite, à l'aide de la pièce de connexion (E).
3. Lors de l'assemblage des panneaux inclinés (A), vous devez placer les deux panneaux à un angle de 135 degrés, puis utiliser les pièces de connexion inclinées (I) et (J) glisser de haut en bas pour fixer les panneaux ensemble.
4. La partie moustiquaire du cadre doit faire face à l'extérieur de l'unité.
5. Les rails du cadre de porte se trouvent à l'intérieur de l'unité.
6. Lorsque vous faites glisser la partie I, J et E dans les cadres, secouez les cadres pour qu'ils glissent également. N'appliquez pas de force excessive. Assurez-vous que les bords sont propres de toute peinture supplémentaire si nécessaire, utilisez une lime fine.

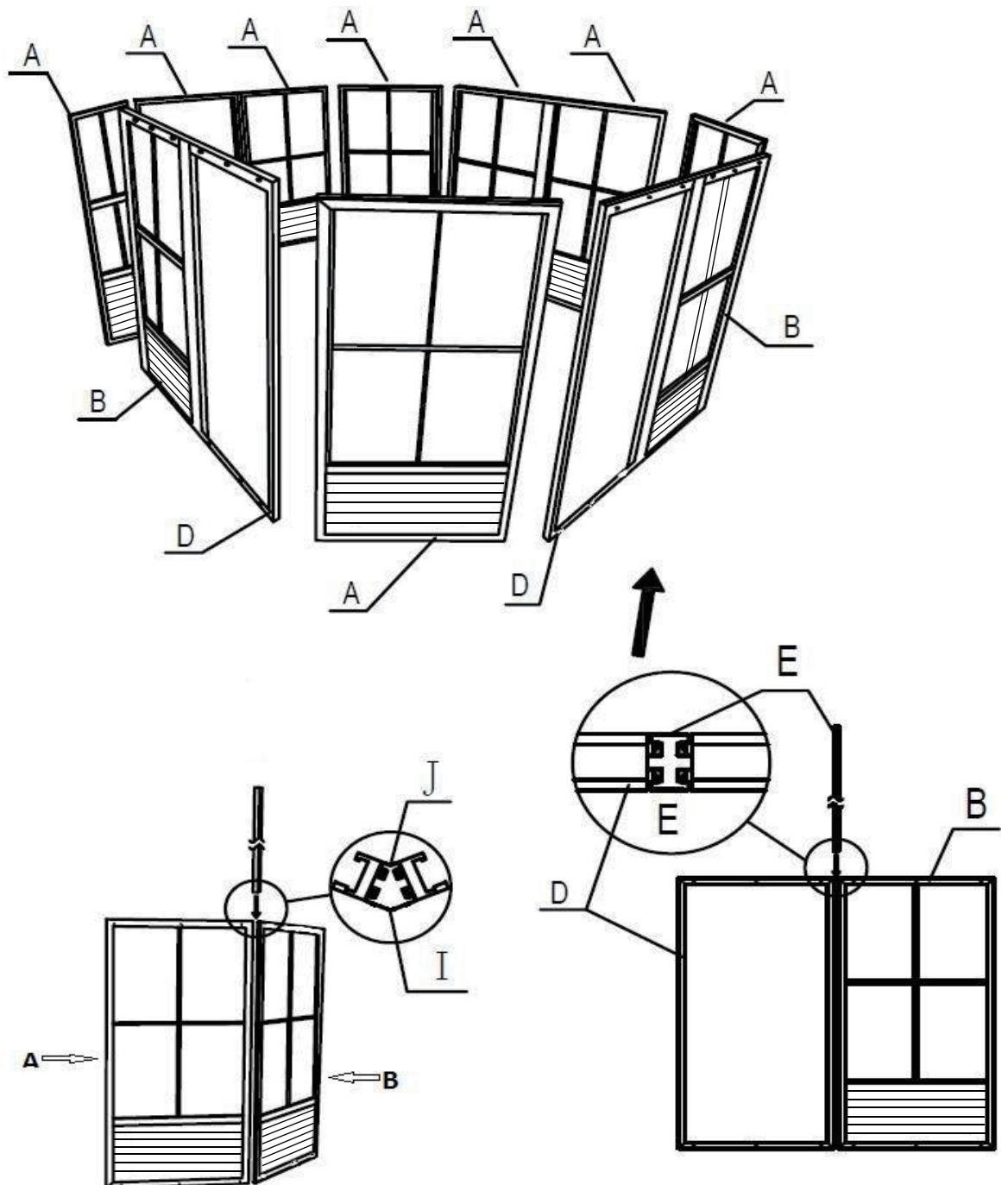

Étape 2:

1. Attachez les barres de recouvrement (P/P-1) en les faisant glisser sur le dessus de la rainure extérieure des cadres (A, B, D).

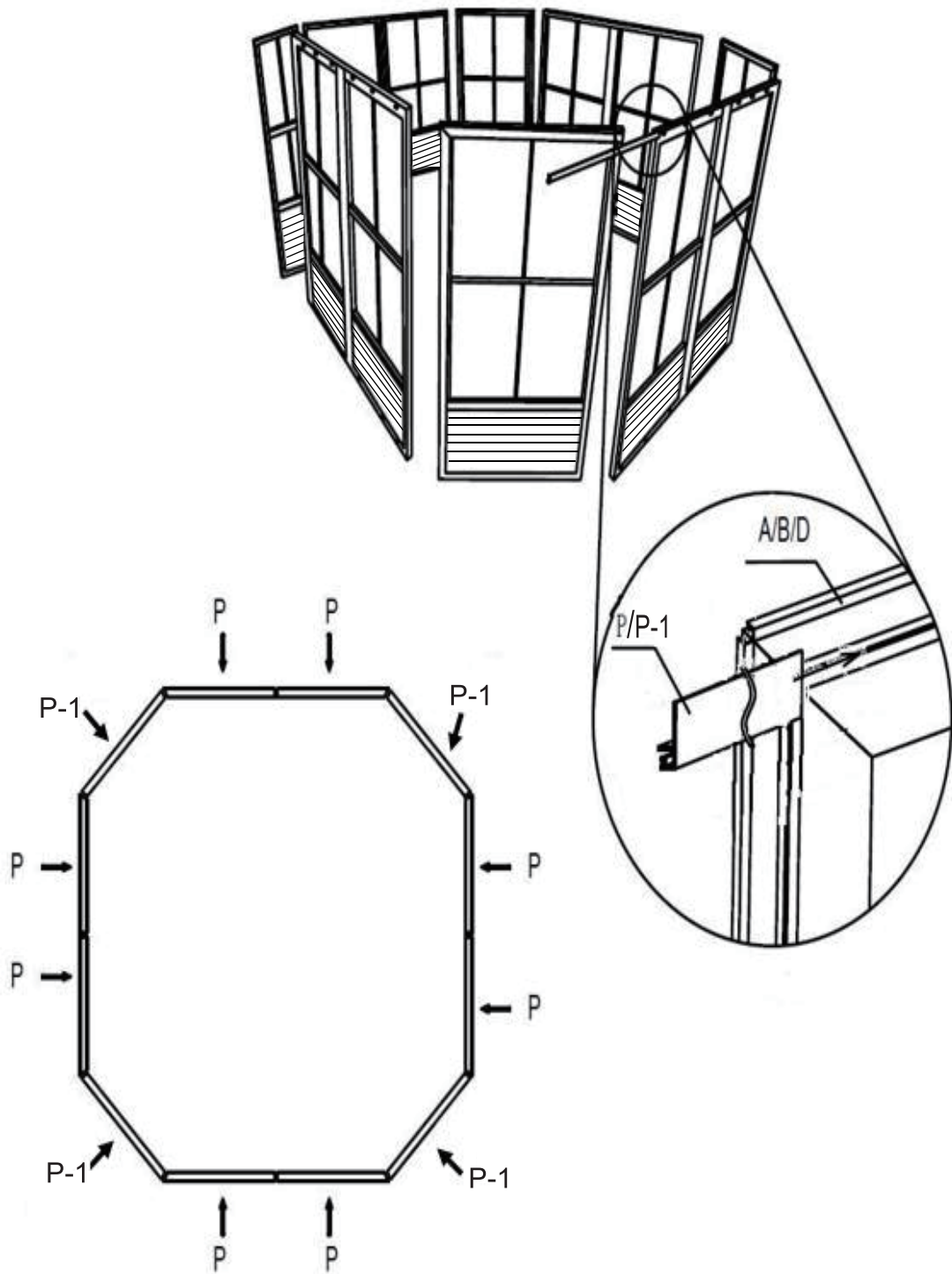

Étape 3:

1. Faites glisser le rail supérieur de la porte (F) dans les roues de la porte coulissante (C).
2. Faites glisser le rail inférieur de la porte (G) dans le guide en plastique de la porte coulissante (C).
3. Utilisez des boulons (Bb) pour attacher les bouchons en plastique (H), un à chaque extrémité du rail supérieur de la porte (F).
4. À l'aide d'une vis (Oo), attachez les capuchons d'extrémité (Nn), un à chaque côté du rail supérieur de porte (F).

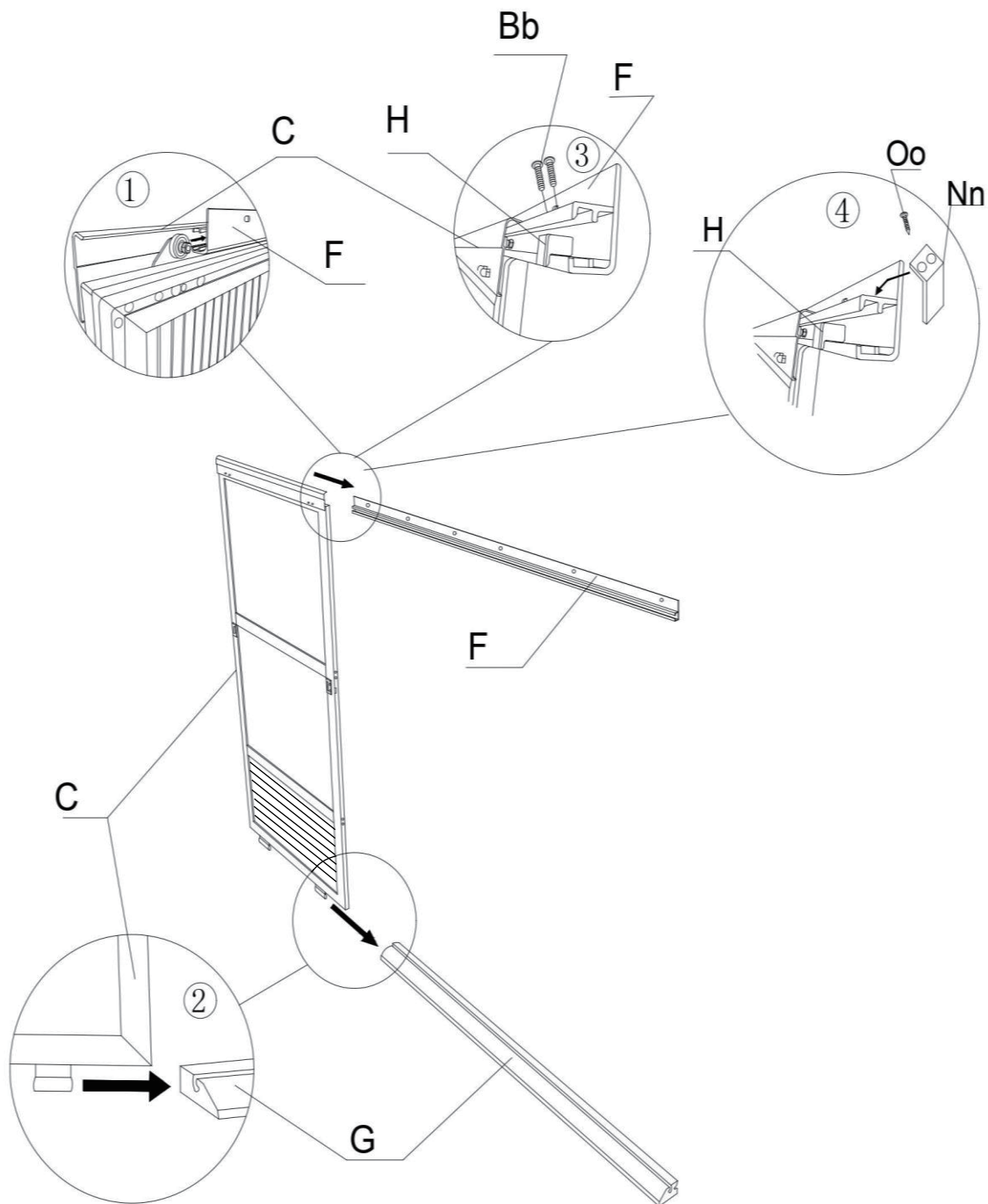

#### Étape 4:

Veillez noter qu'il est recommandé d'installer la porte vers l'intérieur du solarium.

1. Placez un boulon (Ww) à travers le cadre supérieur de porte (D) et le rail supérieur de porte (F), et placez un boulon femelle (Cc-2) de l'autre côté. Une fois tous insérés, serrez-les fermement.
2. Sécurisez le rail inférieur de la porte (G) à l'aide d'un boulon (Cc).
3. Utilisez le boulon (Bb) pour fixer le loquet de porte (Dd-R, Dd-L) sur le cadre.

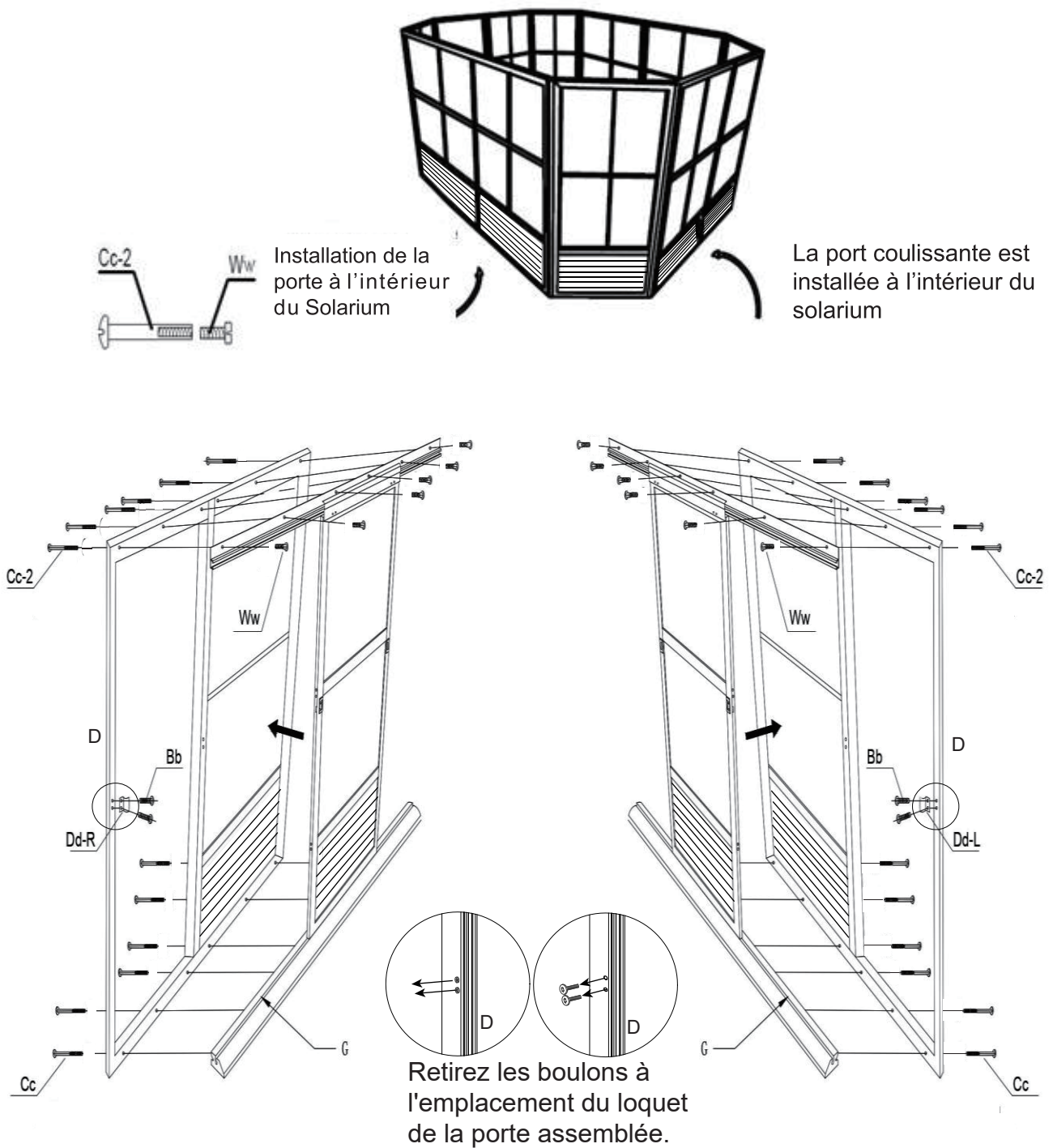

## Étape 5:

- 5.1. Attachez les chevrons de toit (K) au moyeu central (N) à l'aide des boulons (Bb).
- 5.2. Fixez les chevrons du toit (K) au moyeu central (N) à l'aide des boulons (Bb).
- 5.3. Utilisez les vis (Z) pour fixer les chevrons (K) sur le dessus des panneaux passant par la pièce de métal (Z1) attachée au chevron (K).

### Note:

1. Les chevrons doivent être attachés là où les panneaux se connectent les uns aux autres.
2. Attachez le chevron (K) de telle sorte que les trous supplémentaires sur le support (Z1) se font face comme illustré ci-dessous.

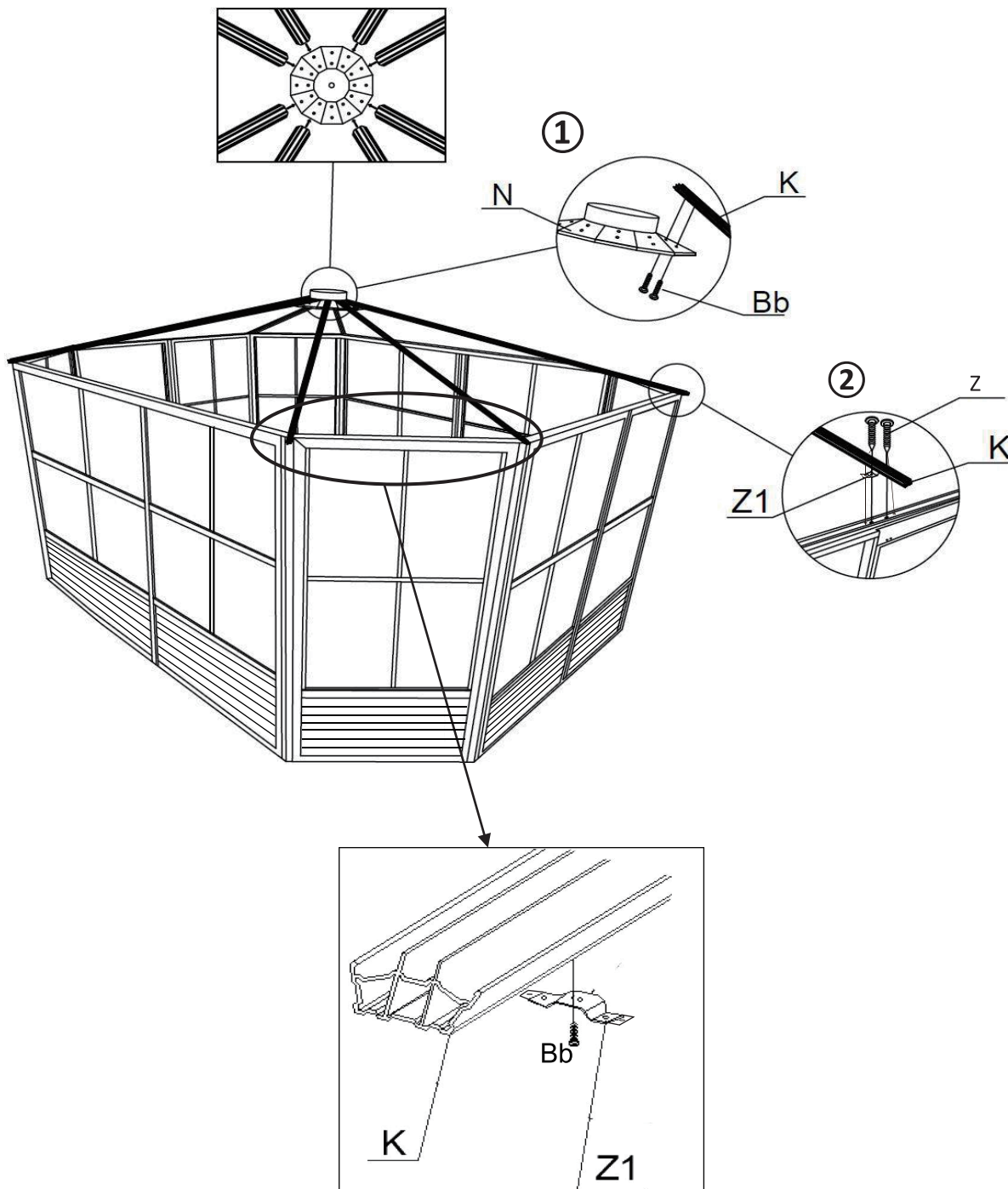

## Étape 6:

1. Assembler l'angle en acier (Z2) aux supports de toit (L) à l'aide de boulons (Bb).
2. Suivez la même procédure que celle du chevron (K) pour assembler les chevrons de toit (L) sur les panneaux restants.

Note: Ne serrez pas les boulons tout de suite car vous devrez peut-être ajuster l'angle lors de l'insertion des panneaux de toit.

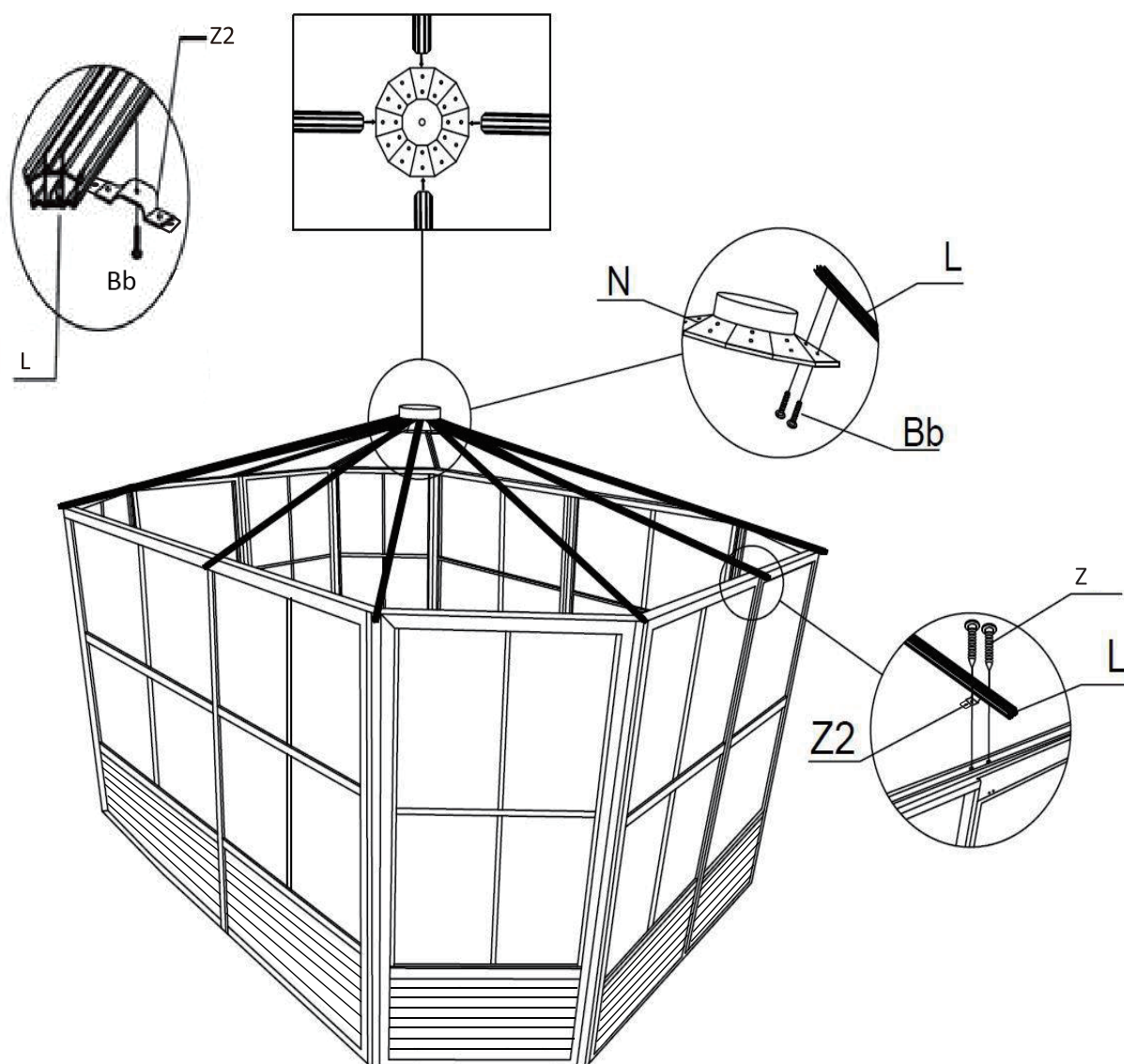

## Étape 7:

1. Attachez les côtés du toit avec la barre de finition (S, U et U1) avec les boulons (Bb) et les supports R.
2. Connectez les barres de finition du toit (S, U, et U1) les unes aux autres en alignant les trous. Placez les capuchons d'extrémité (R) sous les trous alignés et fixez-les avec des boulons (Bb).
3. Répétez le processus avec les barres de finition restantes comme illustré.
4. Pour terminer l'installation de la dernière barre de finition (S, U et U1), vous devez dévisser les premiers boulons (Bb) à votre point de départ et placer un capuchon d'extrémité (R), puis réinstaller les boulons (Bb).

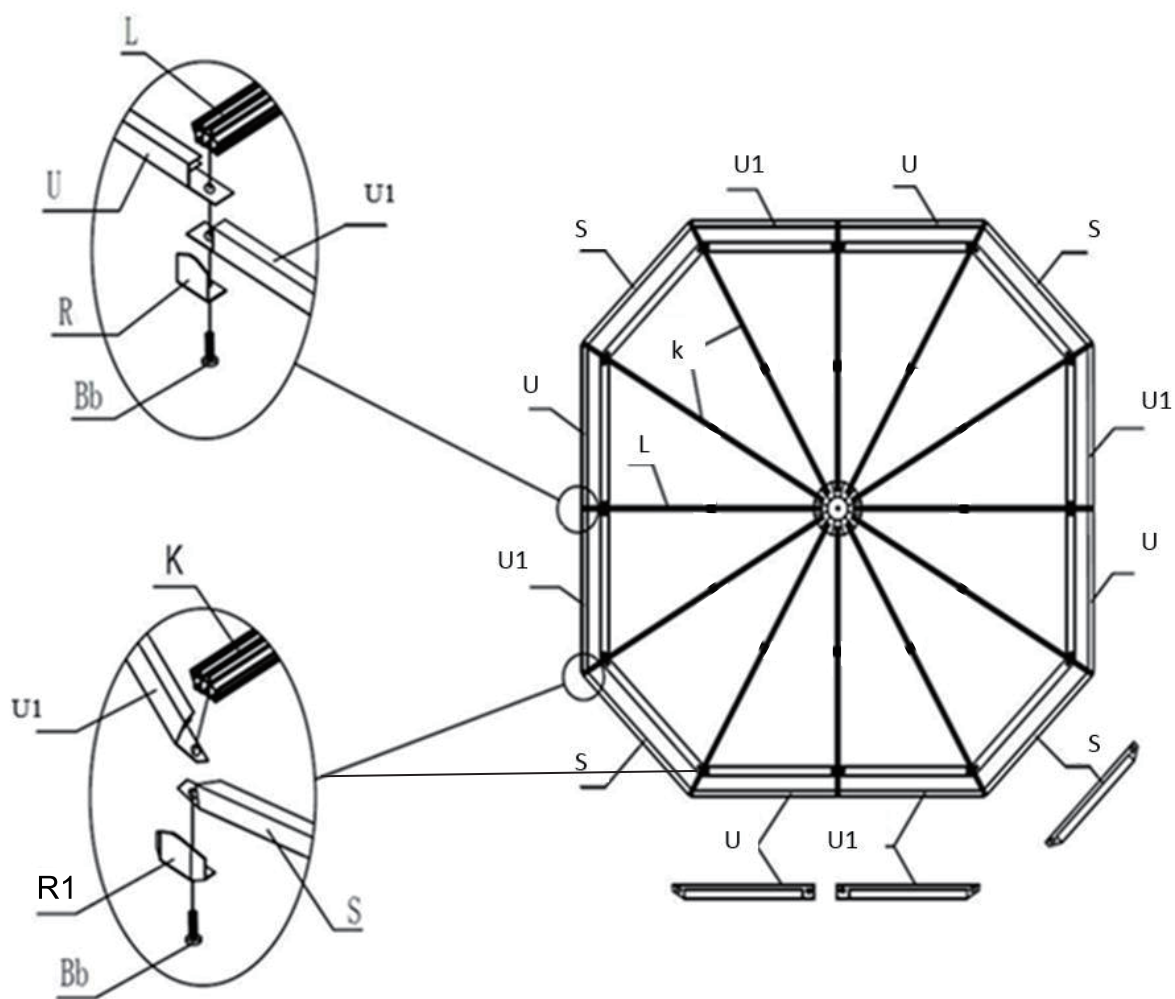

**Vue de dessus**

Étape 8:

1. De l'intérieur du solarium, installez tous les supports (Pp) à l'aide des boulons (Bb) sur les chevrons L.
2. De l'intérieur du solarium, installez tous les supports (Pp-1) à l'aide des boulons (Bb) sur les chevrons K.
3. De l'intérieur du solarium, installez la barre de solidification (T, V et V1) comme illustré à l'aide des boulons (Bb).

NOTE : Assurez-vous que toutes les vis / boulons sont serrés.

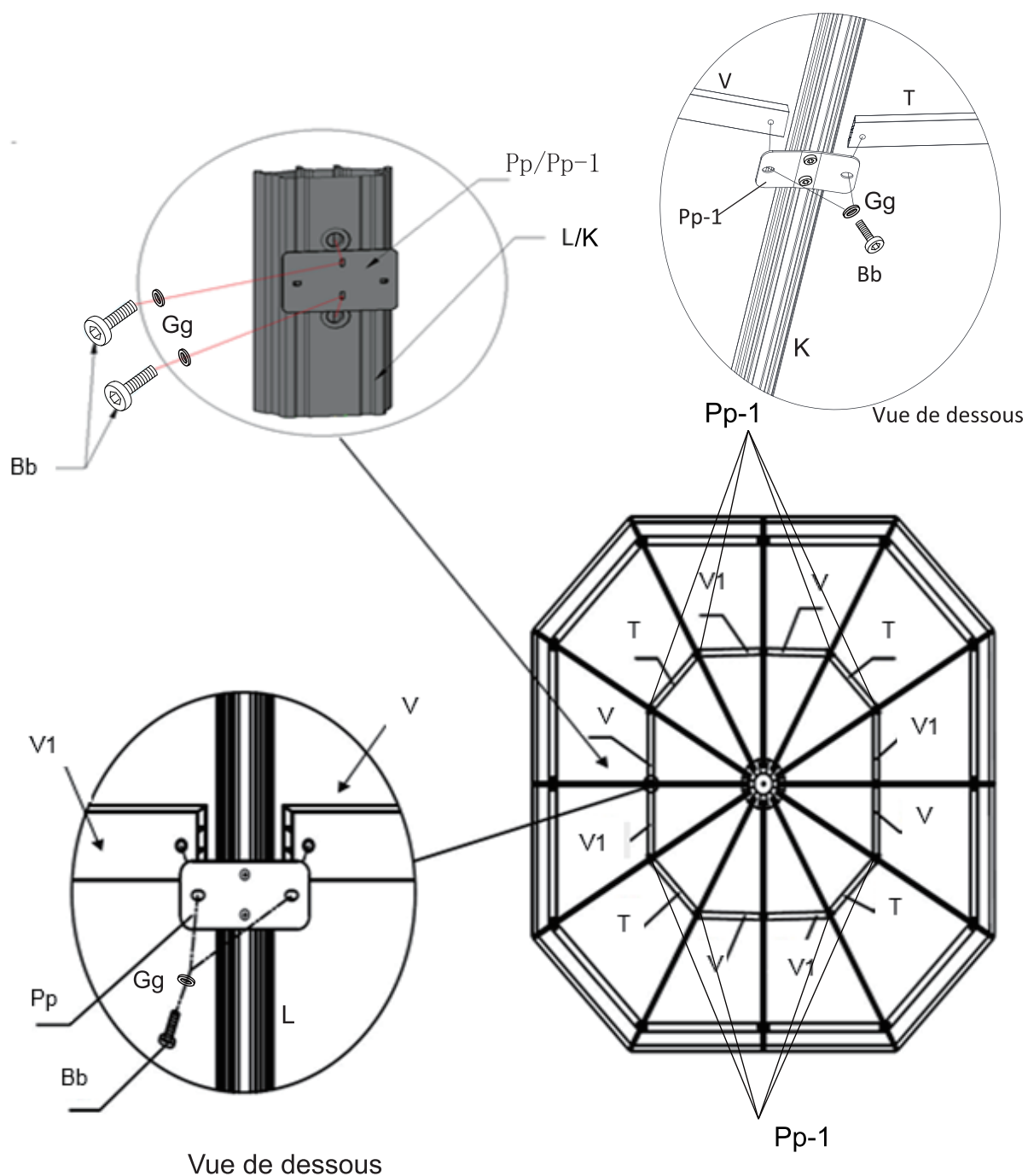

Étape 9:

1. Installez les panneaux de toit inférieurs (Jj, Kk et Mm) en les faisant glisser dans la barre de finition (S, U, U1).

NOTE:

1. Veuillez-vous référer aux autocollants pour savoir comment placer les panneaux de toit.

2. Assurez-vous que toutes les vis / boulons sont serrés.

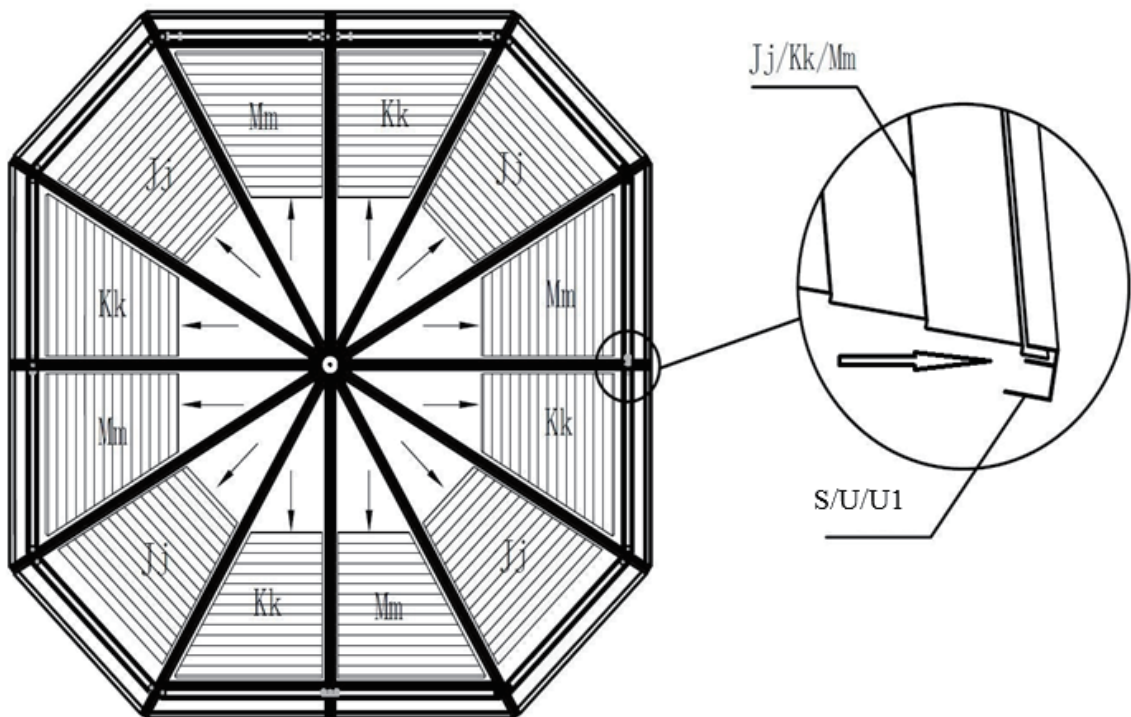

**Vue de dessus**

Étape 10:

1. Installez le panneau de toit supérieur (Aa) en le faisant glisser sur les chevrons de toit (K).

**NOTE:** Veuillez-vous référer aux autocollants pour savoir comment placer les panneaux de toit.

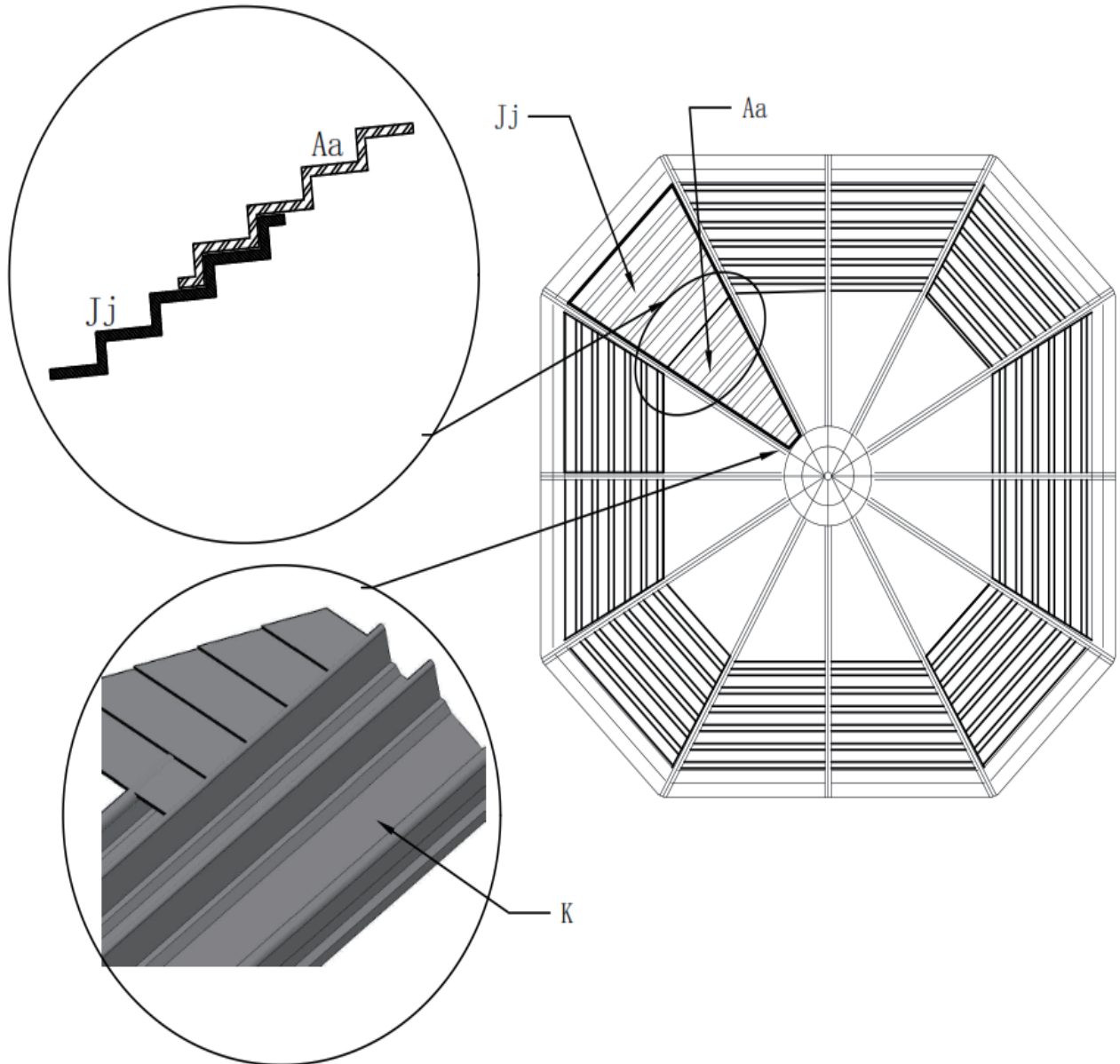

Étape 11:

1. Une fois l'installation du panneau de toit (Aa) terminée, sécurisez-le sur le chevron d'un côté de votre choix à l'aide du couvercle de chevron (0) et des vis (Oo1), puis placez un autre panneau de toit et répétez cette étape.

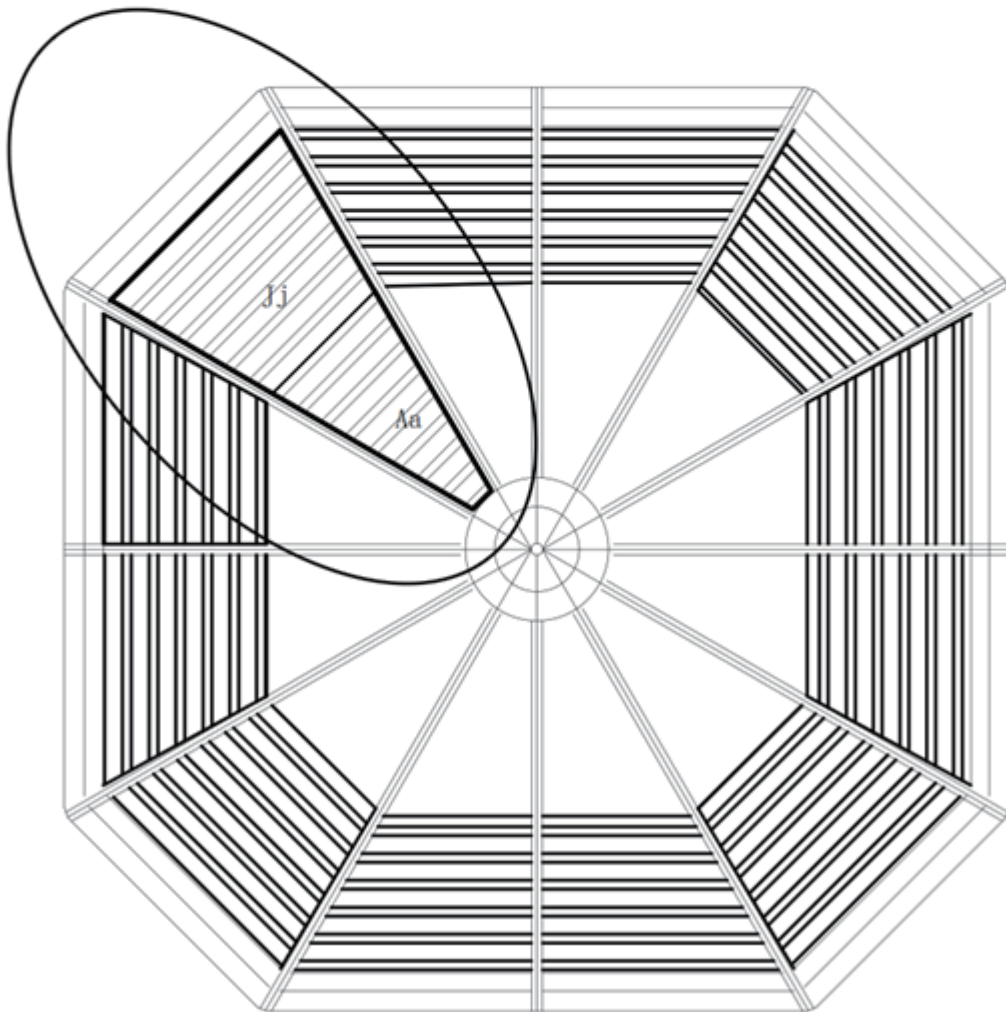
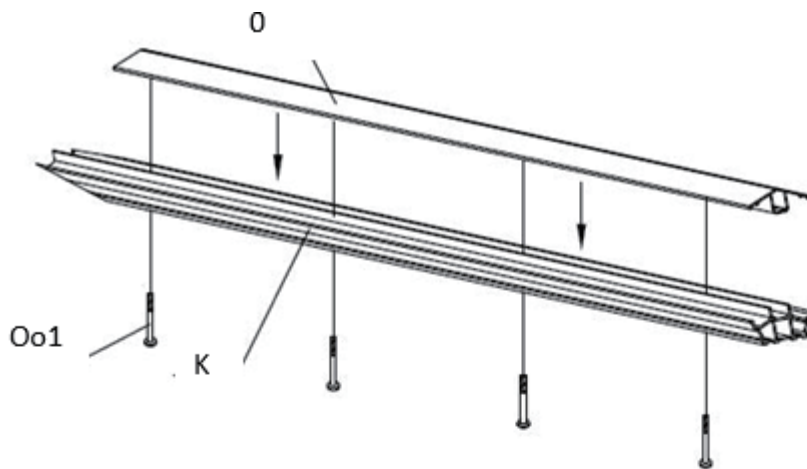

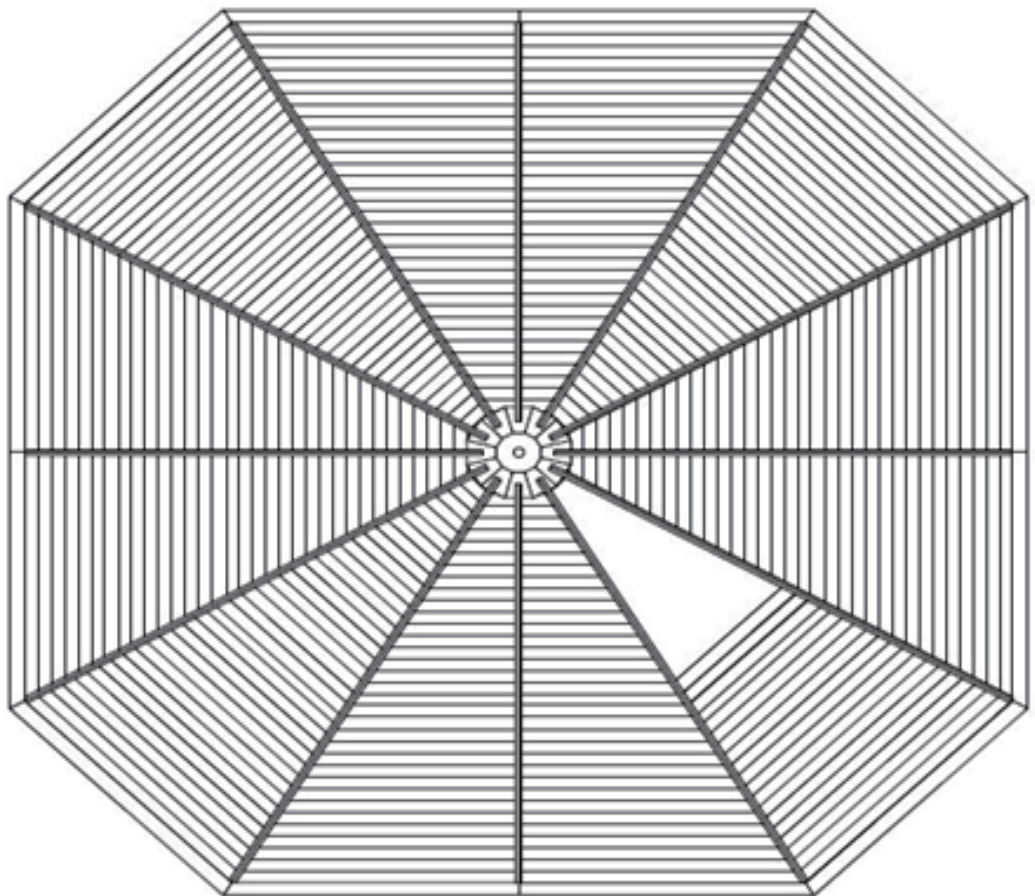
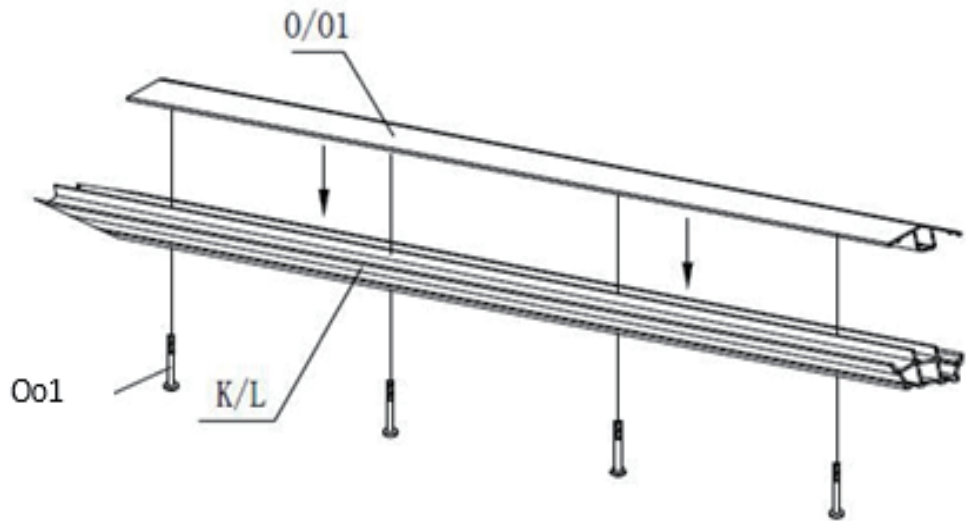

Étape 12:

1. Placez le capuchon supérieur (M) sur le dessus du moyeu central (N).

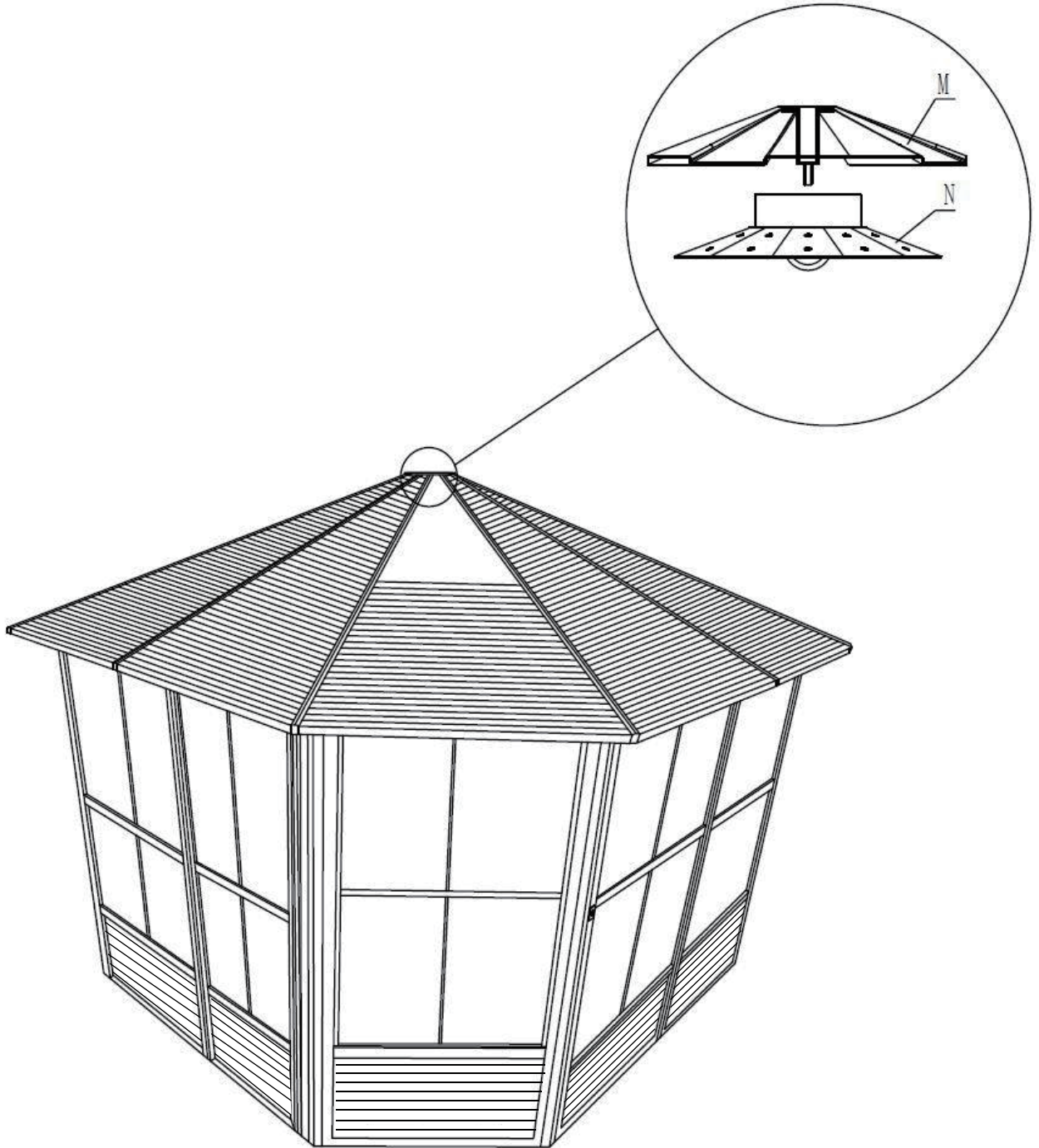

Étape 13:

1. Installez le dernier panneau de toit (Aa).

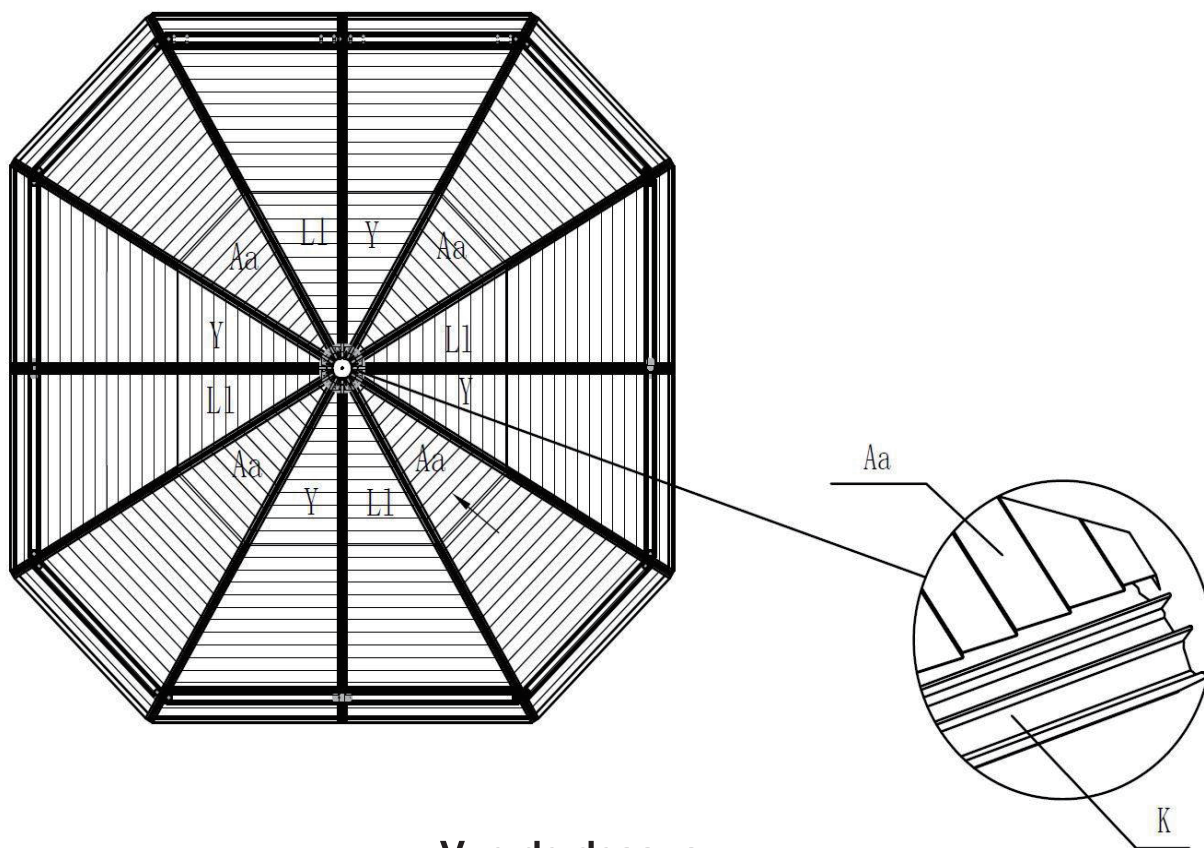

Étape 14:

1. Une fois le dernier panneau de toit installé, vissez la dernière couverture pour chevrons (O) au chevron (K) avec les boulons (Oo1).

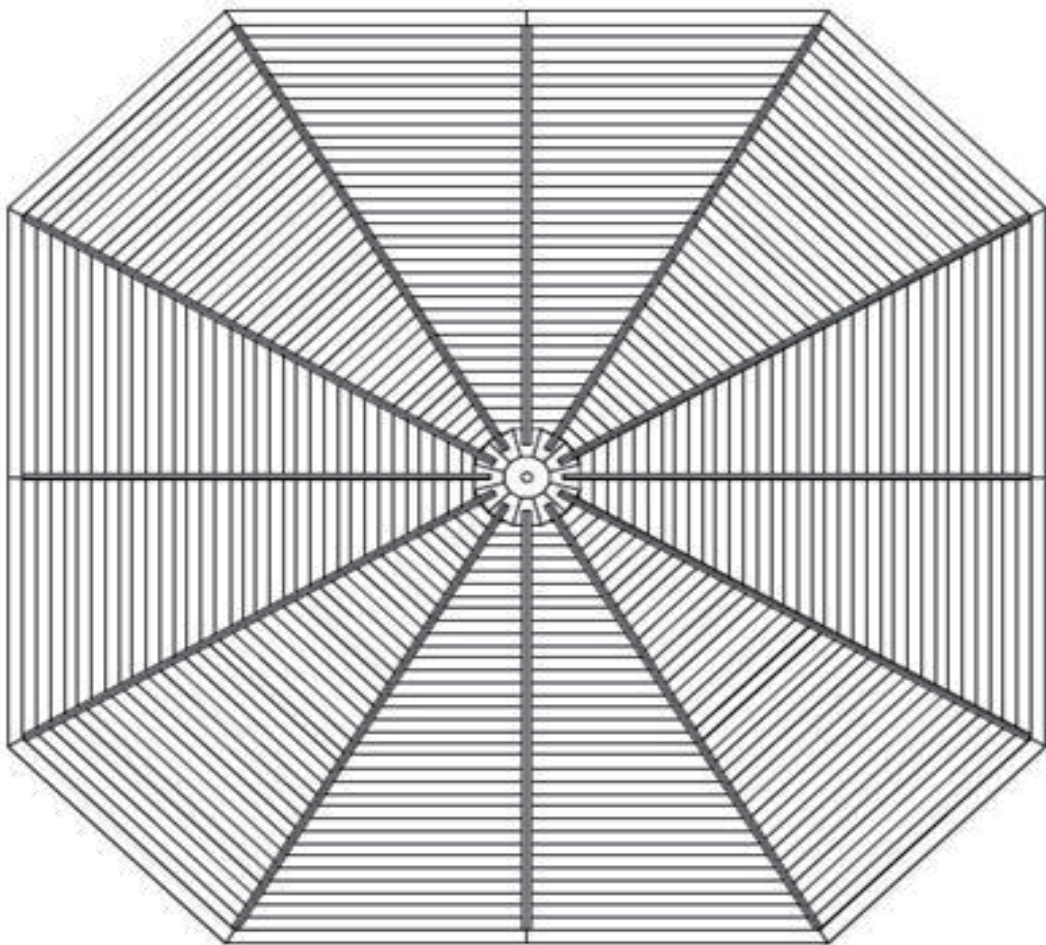
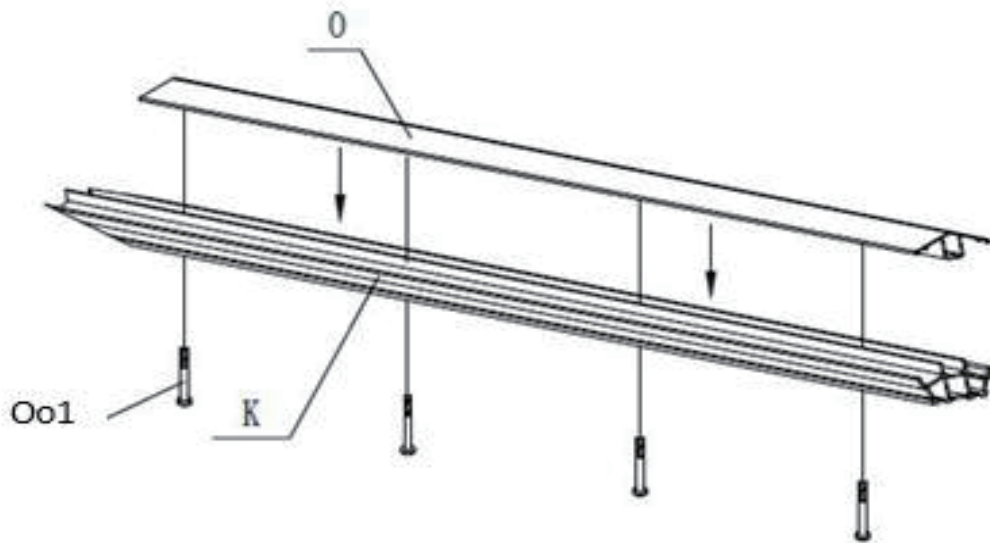

Étape 15:

1. Utilisez un écrou borgne (Hh) et une rondelle (Gg) pour attacher le capuchon supérieur (M) sur le moyeu central (N).

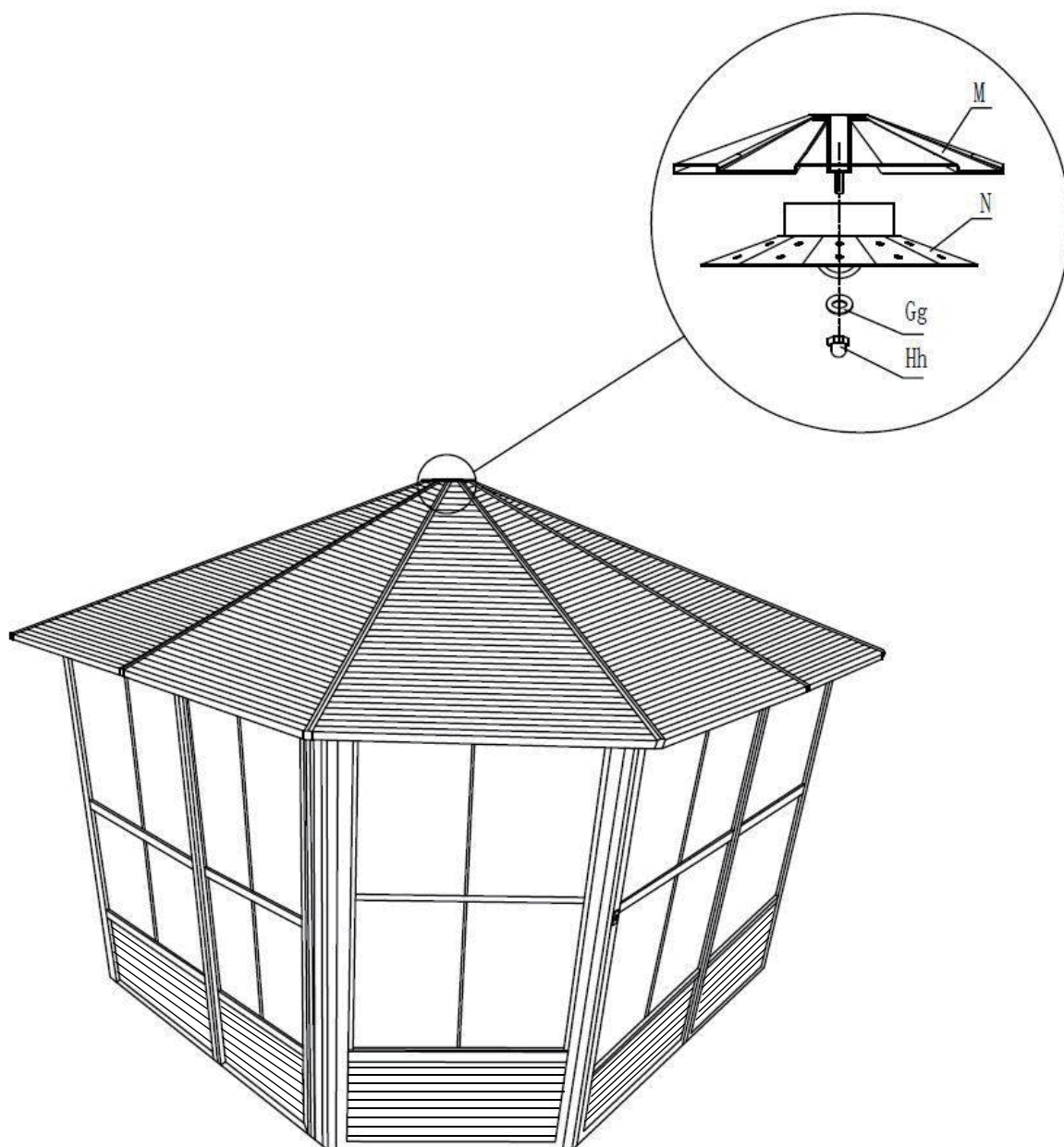

## **\*Suggestions**

Les éléments mentionnés ci-dessous ne sont que des suggestions afin de permettre le drainage, elles varieront en fonction de votre revêtement de sol - matériel, platitude et pente.

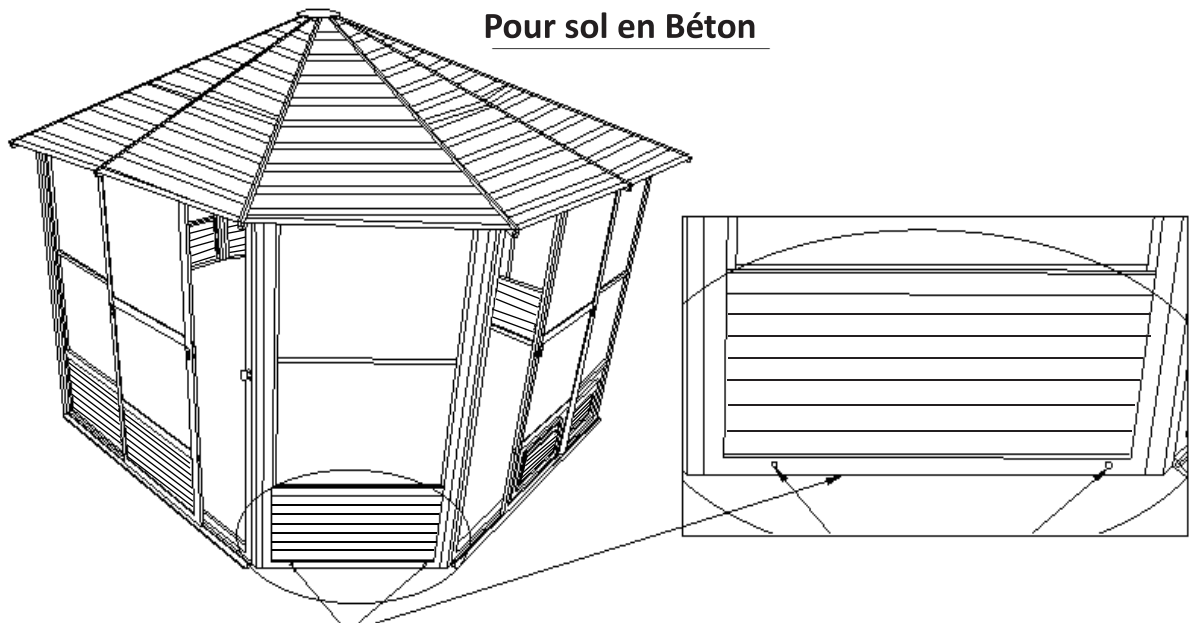

Sur la face extérieure, il est suggéré de percer de trous à l'extrémité inférieure des panneaux pour permettre le drainage

## **Pour Deck en bois**

Forez les ponts où se trouvent les trous de drainage pour permettre de l'eau passer à travers.

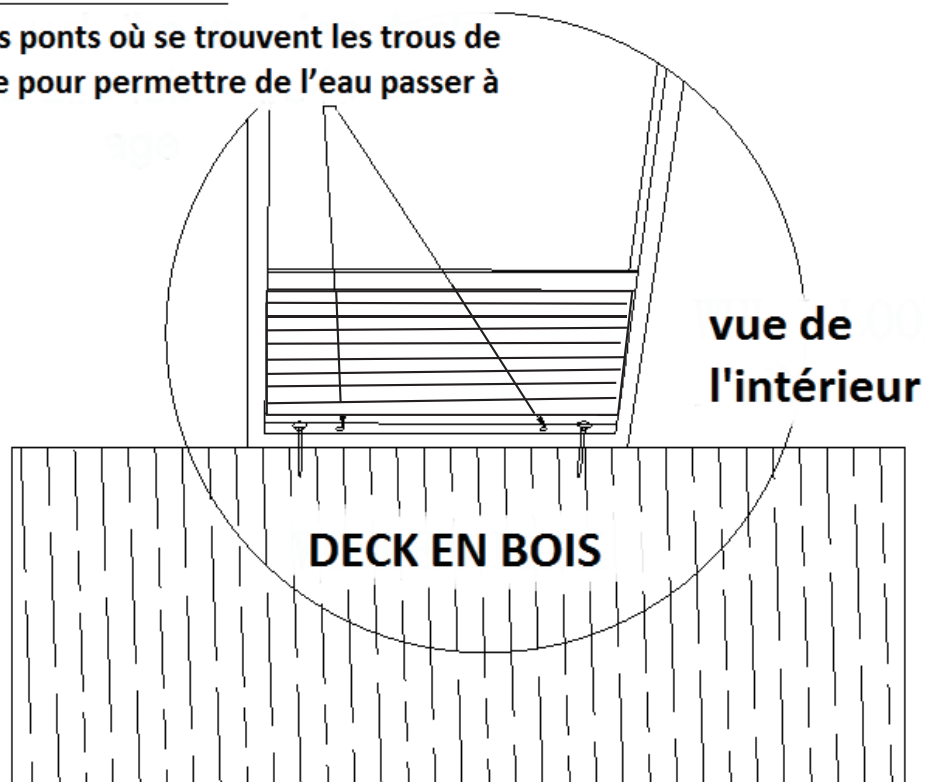

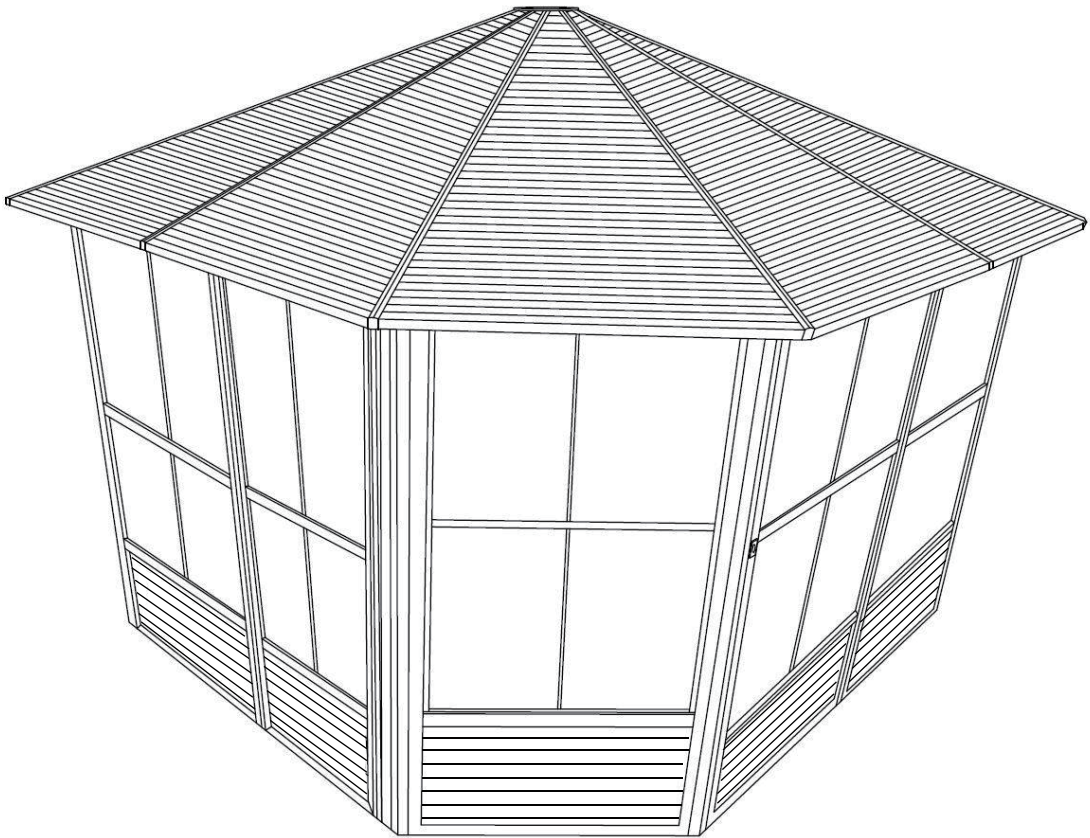
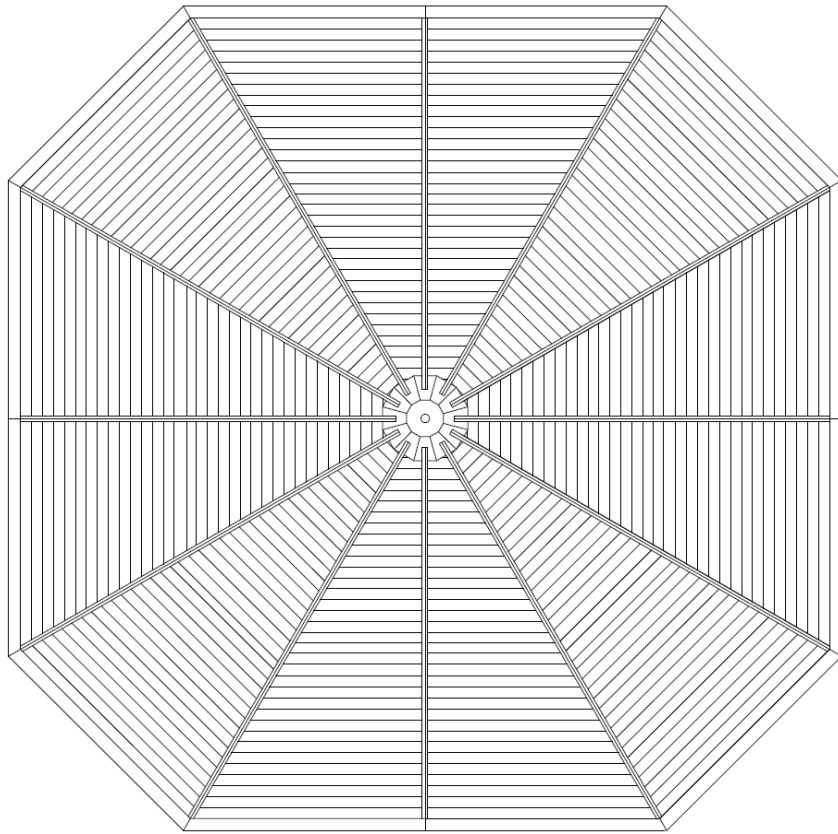

# GARANTIE

Inspectez soigneusement le contenu de l'emballage afin de vérifier si certaines composantes sont manquantes ou endommagées. Advenant que certaines pièces soient manquantes ou endommagées, **ne retournez pas le produit à l'endroit où vous l'avez acheté**; contactez plutôt le département d'expérience client de Gazebo Penguin

Montréal : (514) 276-3485

Ailleurs au Canada et États-Unis : 1-800-737-7174

info@gazebopenguin.com

Ce produit a été conçu et fabriqué afin de répondre aux normes les plus exigeantes en matière de qualité et de durabilité.

Sous réserve de la section « limitations et exclusions à la garantie » ci-dessous, il est garanti contre les défauts matériels ou de fabrication:

- **1 AN SUR LES DÉFAUTS MANUFACTURIERS**

Advenant que le produit soit endommagé ou que la période de garantie soit expirée, veuillez contacter le département d'expérience client de Gazebo Penguin afin d'obtenir une liste complète des pièces de remplacement et des prix.

## LIMITATIONS ET EXCLUSIONS À LA GARANTIE

- 1. Dommages non couverts:** Cette garantie ne couvre pas les dommages causés par le vent, la chute d'objets, le feu, les animaux, la végétation, le vandalisme, les conditions climatiques extrêmes, ni les effondrements dus à l'accumulation de neige et de glace.
- 2. Entretien du toit:** Le toit doit rester libre de toute accumulation de neige ou de glace. Ces accumulations doivent être retirées en sections de cinq pieds (5) à la fois, de droite à gauche. Les dommages causés par un défaut d'entretien du toit ne sont pas couverts par la garantie.
- 3. Retrait de neige et de glace:** Le retrait de neige ou de glace depuis l'intérieur du produit est interdit, car il peut causer des dommages au produit.
- 4. Positionnement:** Il est déconseillé de placer le produit à proximité d'immeubles ou d'arbres, car la neige ou la glace peut glisser et s'accumuler sur le toit, provoquant un poids excessif.
- 5. Installation:** La garantie est valide uniquement si le produit est installé conformément aux instructions fournies par Gazebo Penguin. Une installation incorrecte, notamment un ancrage inadéquat, annule la garantie.
- 6. Infiltration d'eau:** Des infiltrations d'eau peuvent survenir en cas de fortes pluies. Consultez le manuel d'instructions pour les positions des fenêtres et les informations sur l'évacuation de l'eau.
- 7. Clause de remplacement:** Nous nous réservons le droit de réparer ou remplacer tout produit ou pièce défectueuse, à notre seule discrétion.
- 8. Modifications:** Toute modification ou ajout au produit annule la garantie.



# MANUEL D'INSTRUCTIONS INSTRUCTION MANUAL

---

**Florence Solarium 12 PI. X 12 PI. - Toit d'Acier**  
**Florence Solarium 12 FT. X 12 FT. - Metal Roof**

---

sku: 41212MR-GP-12		
sku: 41212MR-GP-32		
sku: 41212MR-GP-42		

---

**DO NOT DESTROY THE BOXES UNTIL COMPLETELY ASSEMBLED  
FOR FUTURE REFERENCE,  
TAKE PICTURES OF ALL SIX SIDES OF EACH OF THE BOXES UPON RECEIPT.  
PLEASE VERIFY THE CONTENT OF EACH BOX AGAINST THE LIST OF PARTS**

**12ft x 12ft / 3.66m x 3.66m Meters Solarium**

**Instruction Manual**

**IMPORTANT: RETAIN FOR FUTURE REFERENCE, READ CAREFULLY**

**Consult with your local governing authority / local municipal codes regarding installation of temporary structures before purchase or assembly. Some jurisdictions may require permits for, or otherwise regulate, installation and use.**

For assistance with assembly, installation, parts, or customer service, contact Gazebo Penguin Customer Service Department at the numbers listed below (English & French, Mon-Fri 8:00 AM to 4:00 PM EST):

**Montreal:** (514) 276-3485

**Elsewhere in Canada and the US:** 1-800-737-7174

**WARNING:**

- For outdoor use.
- Snow should be regularly cleared from the roof and not allowed to accumulate.
- Retain your **proof of purchase** for warranty purposes. Also keep the **original boxes** until the installation is complete and correct.
- The unit may take more than 4 hours and 3 people are required for this assembly.



**PRIOR TO ASSEMBLY:**

- Please don't destroy boxes until completely assembled.
- The foundation must be level, flat, and solid, such as concrete or asphalt.
- Keep away from overhead utility lines, tree branches, and other structures.
- Check for underground pipes or wires if digging or drilling is required.
- Do not install near roof lines or other structures that could shed snow, ice, or excessive rain run-off onto the roof top.
- Assemble the structure as close to its final location as possible.
- It is recommended to wear safety gloves, safety glasses, and hard hats for installation.
- Do not hang from, climb on, or stand on the structure or roof.
- Before assembly, read instructions and check that all parts are present in the boxes. If any parts are missing, refer to warranty information.
- A 6ft (1.8m) stepladder, Phillips screwdriver, tape measure, level, mallet, and a tarp to place parts on will be required for assembly (not included).
- Remove top protective film from roof panels prior to assembly; **DO NOT** remove bottom protective film until ready to insert roof panels, so as to identify which side is on top.

**ANCHORING INSTRUCTIONS:**

- Proper anchoring of the frame to the base and the wall is required for safety.
- Any structure not anchored securely has the potential to fly away during high wind causing damage and safety hazard.
- How the item is anchored, and the hardware and tools required, will vary based upon the set up location and are not provided.
- Please check with your local hardware store if for the appropriate anchors for your surface.
- Do not anchor to pavers / pavement slabs because they are not a solid foundation.
- Periodically check the anchors to ensure they remain secure

**CARE AND MAINTENANCE:**

- In case of a defective or damaged part, or for any other questions concerning the product, please contact the manufacturer directly.
- Please have the parts list and part numbers on hand when ordering or requesting replacement parts.











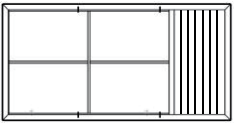

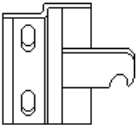
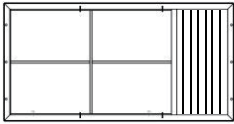
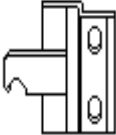

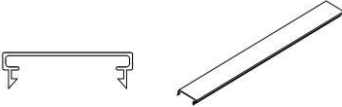
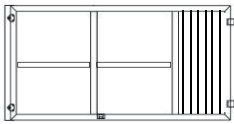





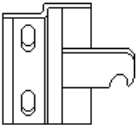
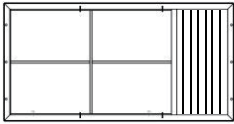
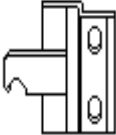

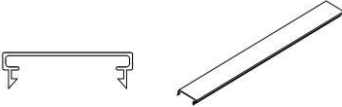
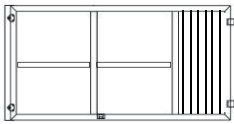

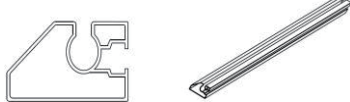

**ROOF PANELS:**

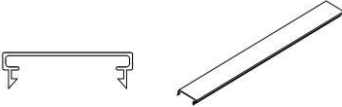
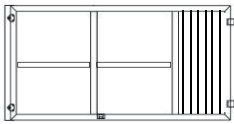



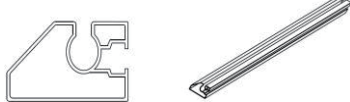

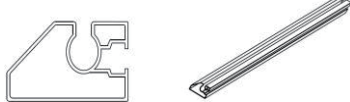

- Gently clean with an environmentally-friendly soap solution and water using a sponge or washcloth.
- Do not use abrasive materials, wire brushes, chemicals, harsh cleaners, or bleach.
- Rinse using a garden hose and air dry. If removed, ensure thoroughly dry prior to storage.
- Do not use pressure washer.

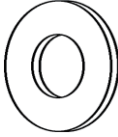
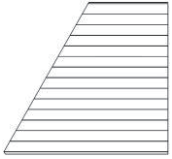
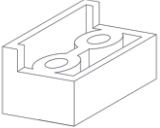

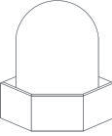
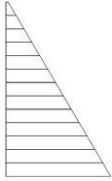

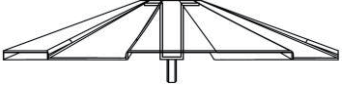

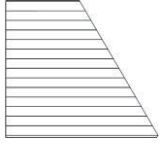

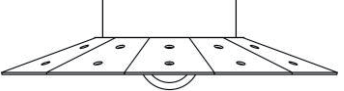
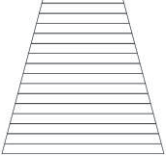
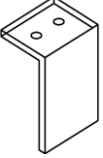
**STRUCTURE:**

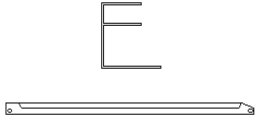

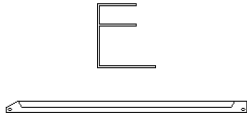
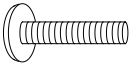
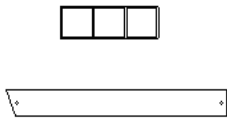

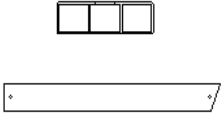

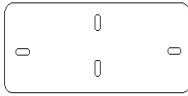
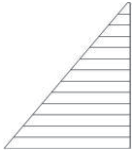
- Gently clean with an environmentally-friendly soap solution and water using a sponge or washcloth.
- Do not use abrasive materials, wire brushes, chemicals, harsh cleaners, or bleach.
- Rinse using a garden hose and air dry.
- Do not use pressure washer.
- If there are nicks, chips, and/or scratches see the part # of the paint in the parts list to obtain a matching touch-up paint.

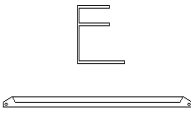
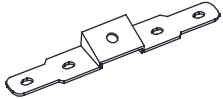
## 12 x 12 Solarium

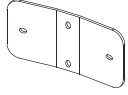
DESCRIPTION	PACKED IN BOX	QTY	DRAWING	DESCRIPTION	PACKED IN BOX	QTY	DRAWING																																																
23-086 REGULAR FRAME A	3	4		08-132 SLIDING DOOR FRAME D	3	1																																																	
	4	4			4	1		17-054 ROOF PANEL Aa	1	4		08-165 DOOR LATCH Dd-R	5	2		23-087 FRAME NEXT TO DOORS (extra holes) B	3	1		08-169 DOOR LATCH Dd-L	5	2		4	1	25-114 SCREW M6*16 Bb	5	108		08-133 CONNECTING PIECE 78.9" E	5	8		23-309 SLIDING DOOR C	3	1		17-043 RAFTER 89.9" K	5	8		4	1	25-115 SCREW M6X73 Cc	5	12		08-136 TOP DOOR RAIL 81.1" F	5	2		25-117 CAPNUT M5X60 Cc-2	5	12	
17-054 ROOF PANEL Aa	1	4		08-165 DOOR LATCH Dd-R	5	2																																																	
23-087 FRAME NEXT TO DOORS (extra holes) B	3	1		08-169 DOOR LATCH Dd-L	5	2																																																	
	4	1						25-114 SCREW M6*16 Bb	5	108		08-133 CONNECTING PIECE 78.9" E	5	8		23-309 SLIDING DOOR C	3	1		17-043 RAFTER 89.9" K	5	8		4	1	25-115 SCREW M6X73 Cc	5	12		08-136 TOP DOOR RAIL 81.1" F	5	2		25-117 CAPNUT M5X60 Cc-2	5	12		08-137 BOTTOM DOOR RAIL 81.1" G	5	2															
25-114 SCREW M6*16 Bb	5	108		08-133 CONNECTING PIECE 78.9" E	5	8																																																	
23-309 SLIDING DOOR C	3	1		17-043 RAFTER 89.9" K	5	8																																																	
	4	1						25-115 SCREW M6X73 Cc	5	12		08-136 TOP DOOR RAIL 81.1" F	5	2		25-117 CAPNUT M5X60 Cc-2	5	12		08-137 BOTTOM DOOR RAIL 81.1" G	5	2																																	
25-115 SCREW M6X73 Cc	5	12		08-136 TOP DOOR RAIL 81.1" F	5	2																																																	
25-117 CAPNUT M5X60 Cc-2	5	12		08-137 BOTTOM DOOR RAIL 81.1" G	5	2																																																	

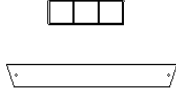

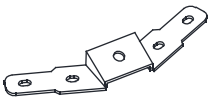



DESCRIPTION	PACKED IN BOX	QTY	DRAWING	DESCRIPTION	PACKED IN BOX	QTY	DRAWING
08-187 WASHER Gg	5	57		17-061 ROOF PANEL Kk	2	4	
08-138 DOOR STOPPER H	5	4		17-044 RAFTER 78.9" L	5	4	
08-189 ACORN NUT Hh	5	1		17-057 ROOF PANEL LI	2	4	
08-139 CONNECTING PIECE 78.9" I	5	8		08-143 Top Cap M	5	1	
17-049 COVER FOR RAFTERS 88.9" O	5	8		17-058 ROOF PANEL Mm	2	4	
08-140 CONNECTING PIECE 78.9" J	5	8		08-144 CENTRAL HUB N	5	1	
17-055 ROOF PANEL Jj	1	4		08-134 UPPER DOOR RAIL END CAP Nn	5	4	

DESCRIPTION	PACKED IN BOX	QTY	DRAWING	DESCRIPTION	PACKED IN BOX	QTY	DRAWING
17-050 COVER FOR RAFTERS 78.5" O1	5	4		17-045 FINISHING BAR 45.2" U	5	4	
08-135 SCREW Oo	5	4		17-071 FINISHING BAR 45.2" U1	5	4	
25-116 SCREW M6X36 Oo1	5	50		17-047 SOLIDIFYING BAR 20.8" V	5	4	
17-051 GAP COVER BAR 39.7" P	5	8		17-070 SOLIDIFYING BAR 20.8" V1	5	4	
23-003 GAP COVER BAR 40.3" P-1	5	4		25-118 SCREW M5X15 Ww	5	12	
18-067 SOLIDIFYING BAR BRACKET Pp	5	4		17-060 ROOF PANEL Y	2	4	
17-053 END CAP R	5	4		08-156 SCREW M5*20 Z	5	48	
17-046 FINISHING BAR 45.3" S	5	4		15-125 STEEL ANGLE Z2	5	4	

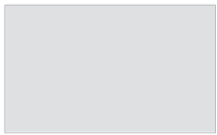
DESCRIPTION	PACKED IN BOX	QTY	DRAWING	DESCRIPTION	PACKED IN BOX	QTY	DRAWING
23-004 SOLIDIFYING BAR BRACKET Pp-1	5	8		23-005 END CAP R1	5	8	
17-048 SOLIDIFYING BAR 20.8" T	5	4		23-215 Allen wrench QQ	5	1	
15-124 STEEL ANGLE Z1	5	8		23-223 Allen wrench RR	5	1	

**\*NOT INCLUDED IN THE BOX**

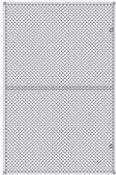
DESCRIPTION	COLOUR	PART #
SPRAY PAINT	SAND	11-699
PAINT PEN		18-245

AVAILABLE REPLACEMENT PARTS			
DESCRIPTION	DRAWING		DRAWING
08-219 PVC WINDOW (in frame)			85-417-S ROUND SPLINE FOR SCREENING
10-493 PVC WINDOW (replacement material only)			23-090 BOTTOM STEEL PANEL (for wall panels)
85-417-P ROUND SPLINE FOR PVC WINDOW			23-091 BOTTOM STEEL PANEL (for doors)
15-123 PIN FOR PVC WINDOW			15-097 DOOR WHEEL ASSEMBLY
13-033 PC WINDOW (for sliding door)			10-458 REPLACEMENT WEATHERSTRIP
12-046 MOSQUITO SCREEN (in frame)			15-124 STEEL ANGLE Z1
85-014 REPLACEMENT SCREENING (no frame)			15-125 STEEL ANGLE Z2
<b>DESCRIPTION</b>	<b>COLOUR</b>	<b>PART #</b>	
SPRAY PAINT	SAND	11-699	
PAINT PEN		18-245	

NOTE: The dimensions are approximate.

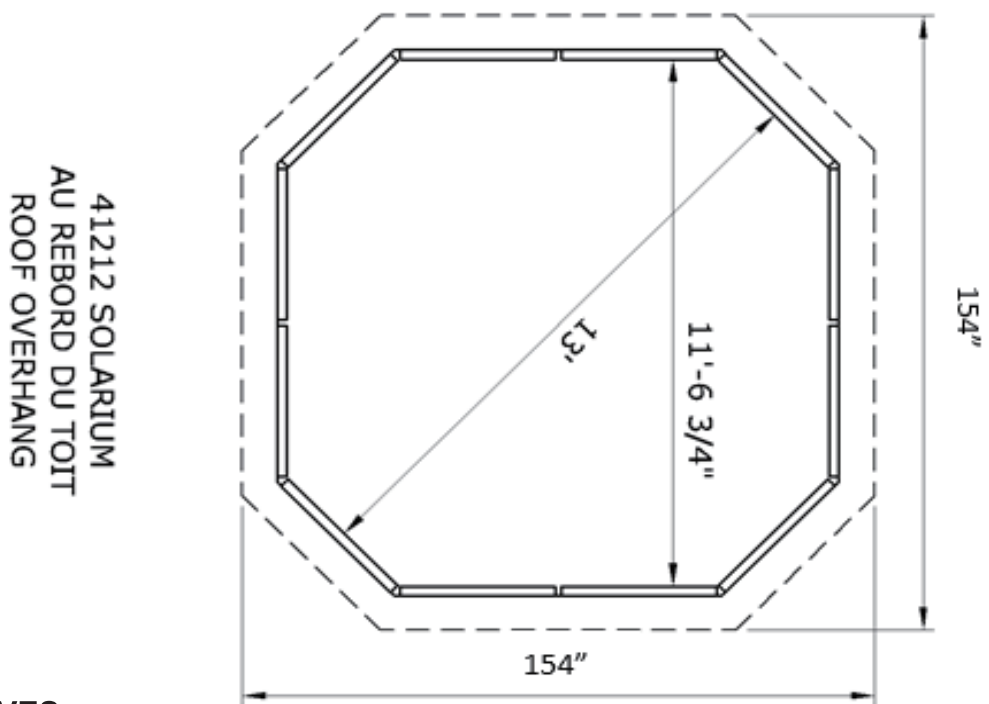
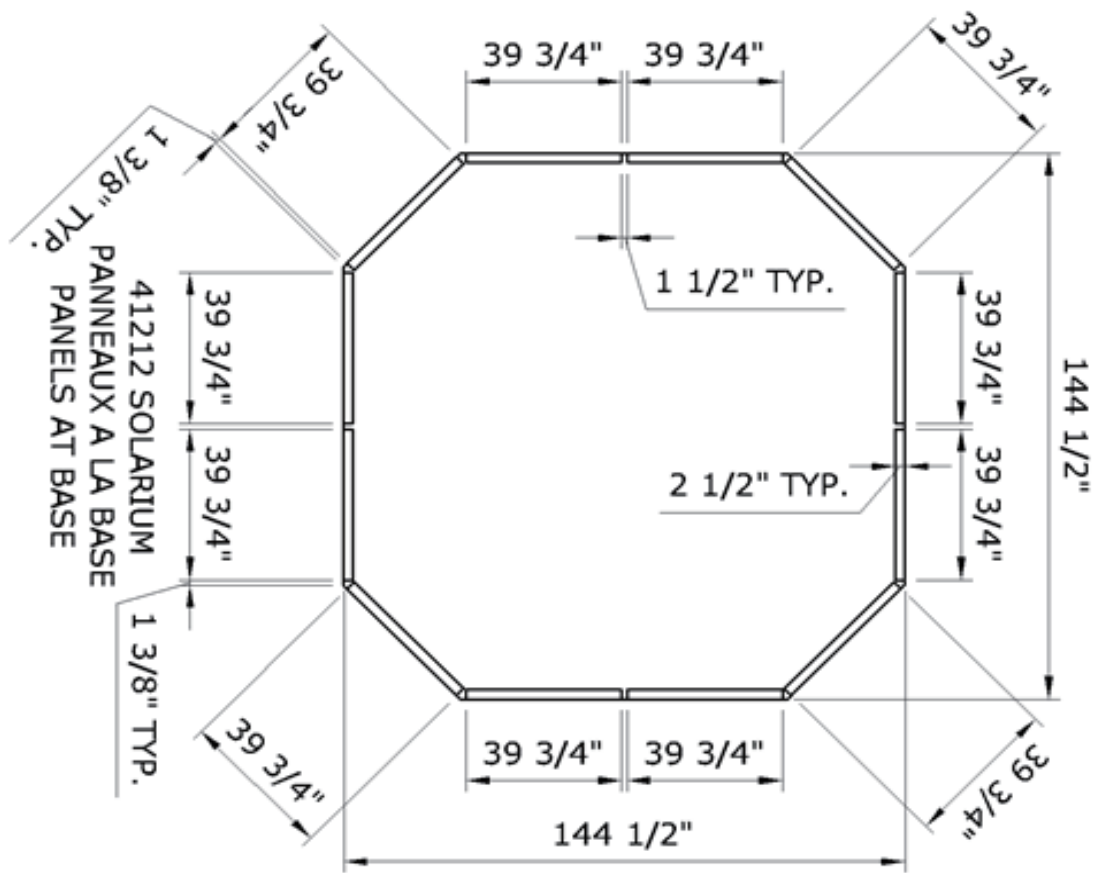

APPROXIMATIVES.

## Before you assemble the Solarium

- Please don't destroy boxes until completely assembled.
- For future reference, take pictures of all six sides of each of the boxes upon receipt.
- Please verify the content of each box against the list of parts.

### Tools needed:

- Step Ladder 6'-8'
- #2 Phillips, #2 Robertson Screwdriver (not supplied)
- Rubber Mallet
- Various Files
- Drill Machine
- Drill bit 1/8" for Pilot holes

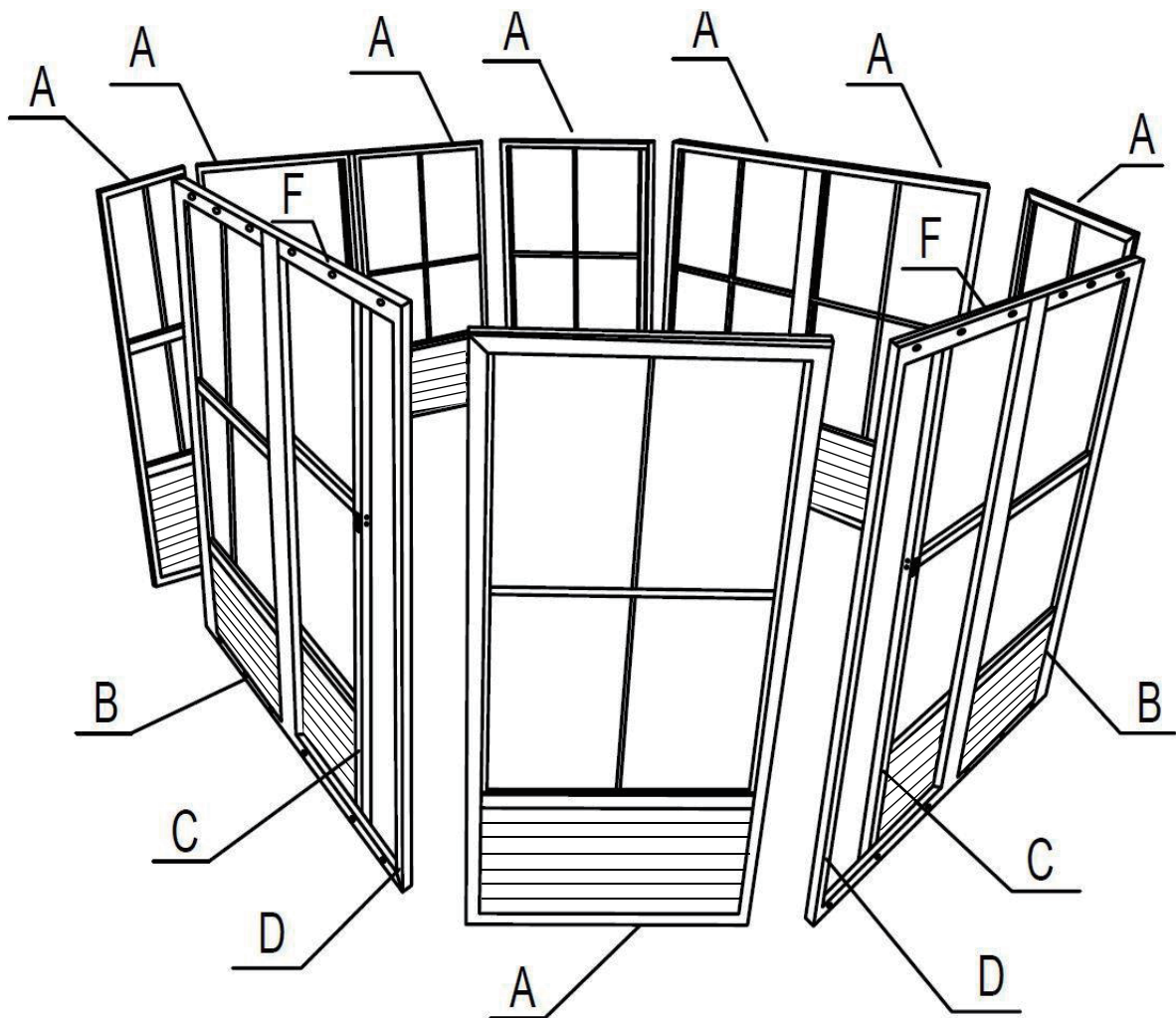

Based on the location, decide where you would like to position the two (2) doors panels which can slide open to the left or the right, your choice.

### Step 1:

1. Stand up two Frames (A), using two Connecting Pieces (I, J) slide from top to bottom and affix the panels together.
2. Stand up a frame meant to be next to the Door (B) and a Door Frame (D), placing the door frame either on the left or right, then use two Connecting Pieces (E) slide from top to bottom to affix the Panel B and Door Frame D.
3. When assembling Angled Panels (A), you should put the two panels at 135 degree angle then use the angled Connecting Pieces (I) and (J) slide from top to bottom to affix the panels together.
4. Frame screening should be facing the outside of the unit.
5. Door frame step down is on the inside of the unit.
6. When sliding the part I, J and E into the frames shake the frames for it too slide. Do not apply excess force. Make sure the edges are clean from any extra paint if necessary use a fine file.

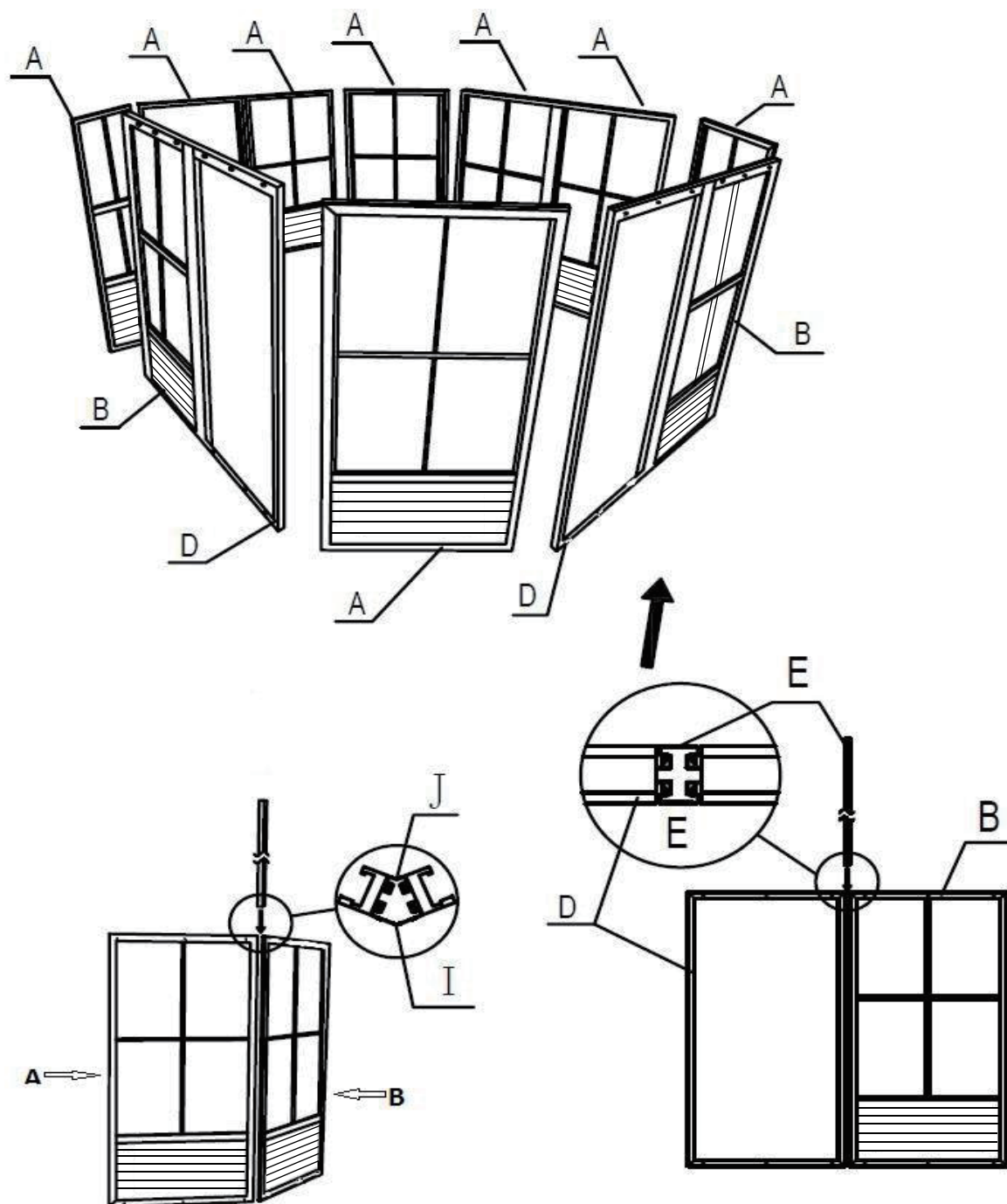

**Step 2:**

1. Affix Gap Cover Bars (P/P-1) by sliding them on top of the exterior groove of the Frames (A, B, D)

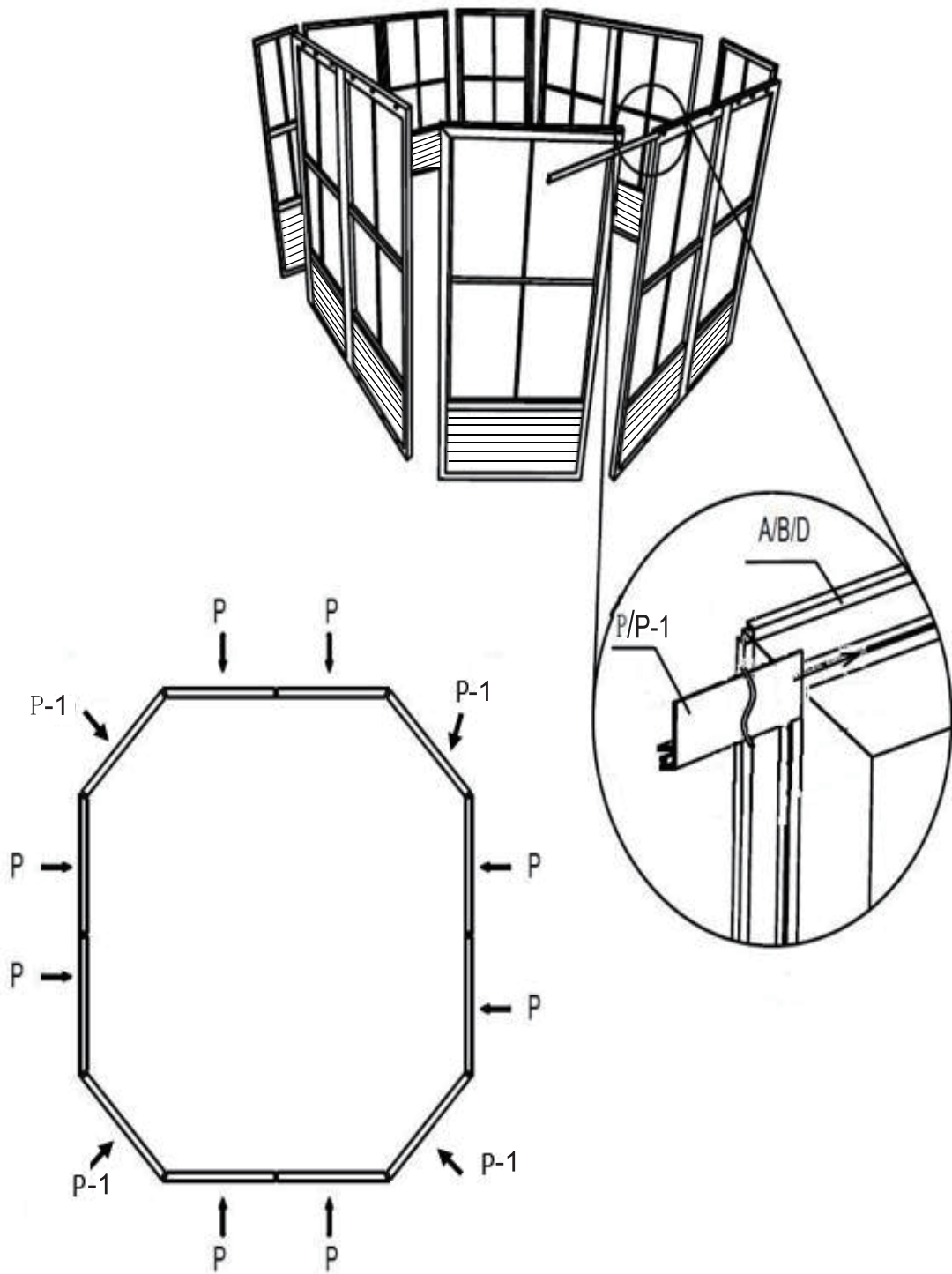

**Step 3:**

1. Slide Top Door Rail (F) into wheels of Sliding Door (C).
2. Slide Lower Door Rail (G) into the plastic guide of the Sliding Door (C).
3. Use Bolts (Bb) to affix the plastic Stoppers (H) one on each end of Top Door Rail (F).
4. Using a Screw (Oo) affix the upper door rail End Caps (Nn) one on each end of Top Door Rail (F).

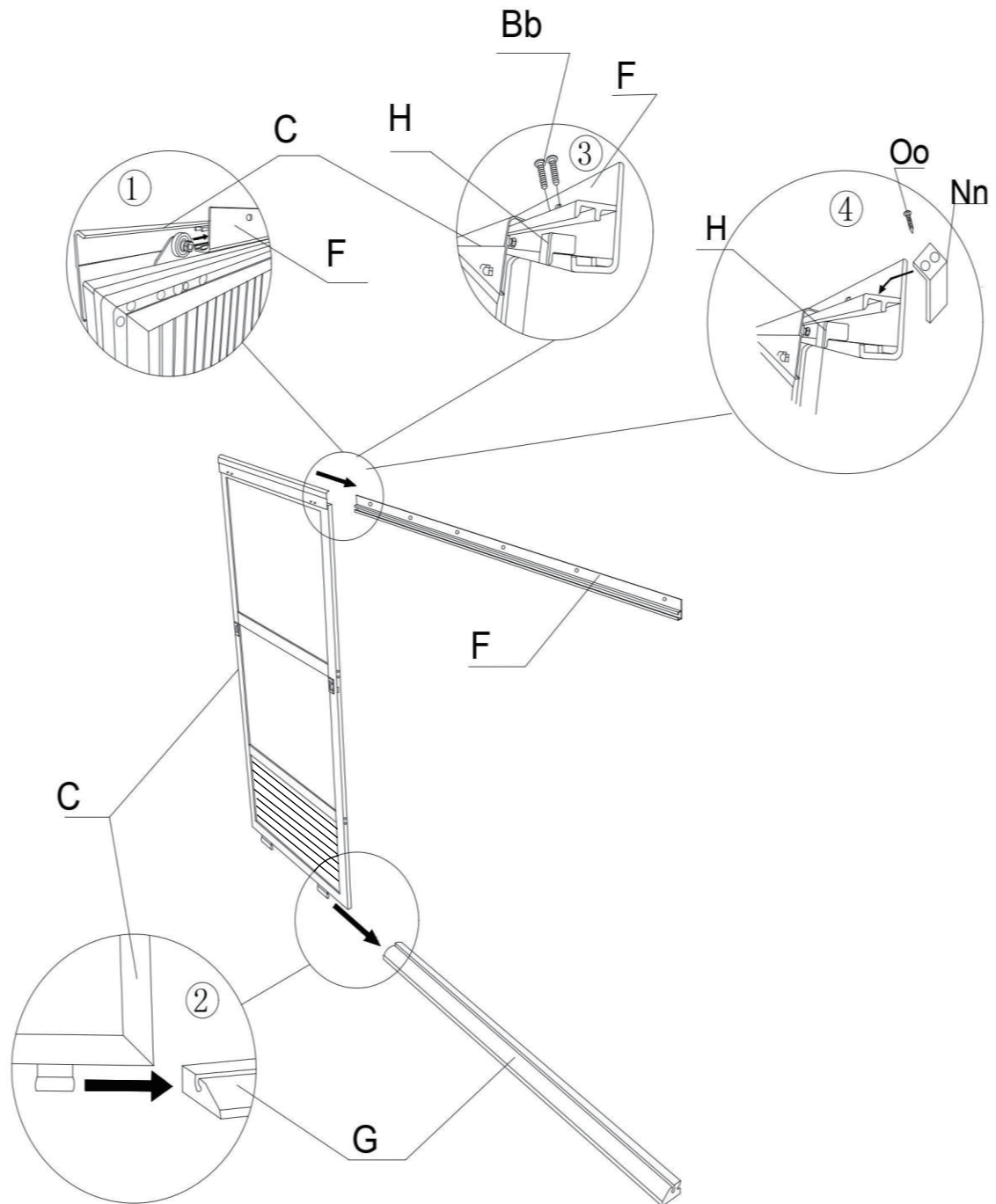

**Step 4:**

**Please note the sliding door is suggested to be installed from the inside of the solarium**

1. Place a Bolt (Ww) through the Top Door Frame (D) and Door Top Rail (F), and place a Female Bolt (Cc-2) from the other side. Once all are inserted, tighten them all securely.
2. Secure the Bottom Door Rail (G), using a Bolt (Cc) .
3. Use Bolt (Bb) to affix the Door Latch (Dd-R, Dd-L) onto the frame.

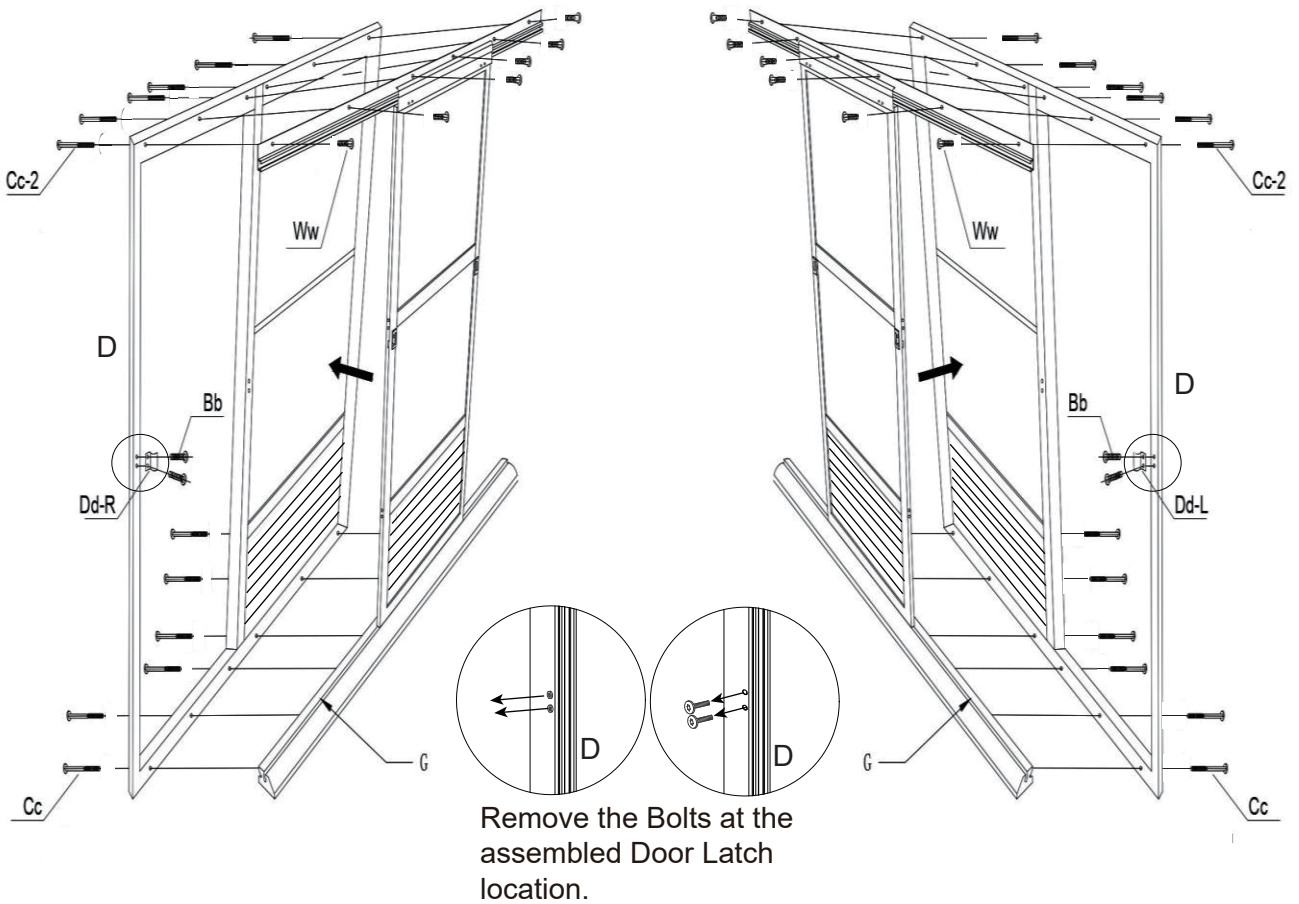
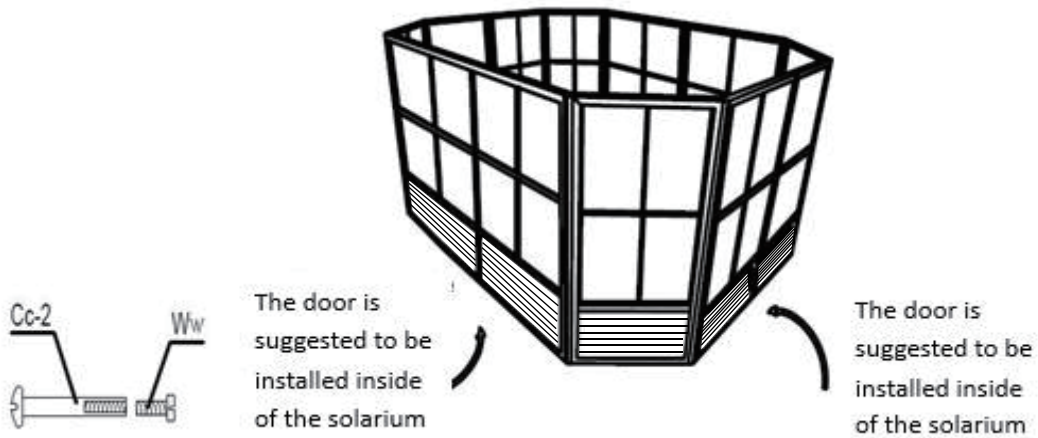

**Step 5:**

1. Assemble steel angle (Z1) to roof Rafters (K) using Bolts (Bb).
2. Attach roof Rafters (K) to the Central Hub (N) using Bolts (Bb).
3. Use Screws (Z) to affix the Rafters (K) onto the top of panels going through the Metal Piece (Z1) attached to the Rafter (K).

**Note:**

1. Rafters must be affixed where panels connect to each other.
2. Affix the Rafter (K) such that, the extra hole on the bracket (Z1) are facing each other as shown below.

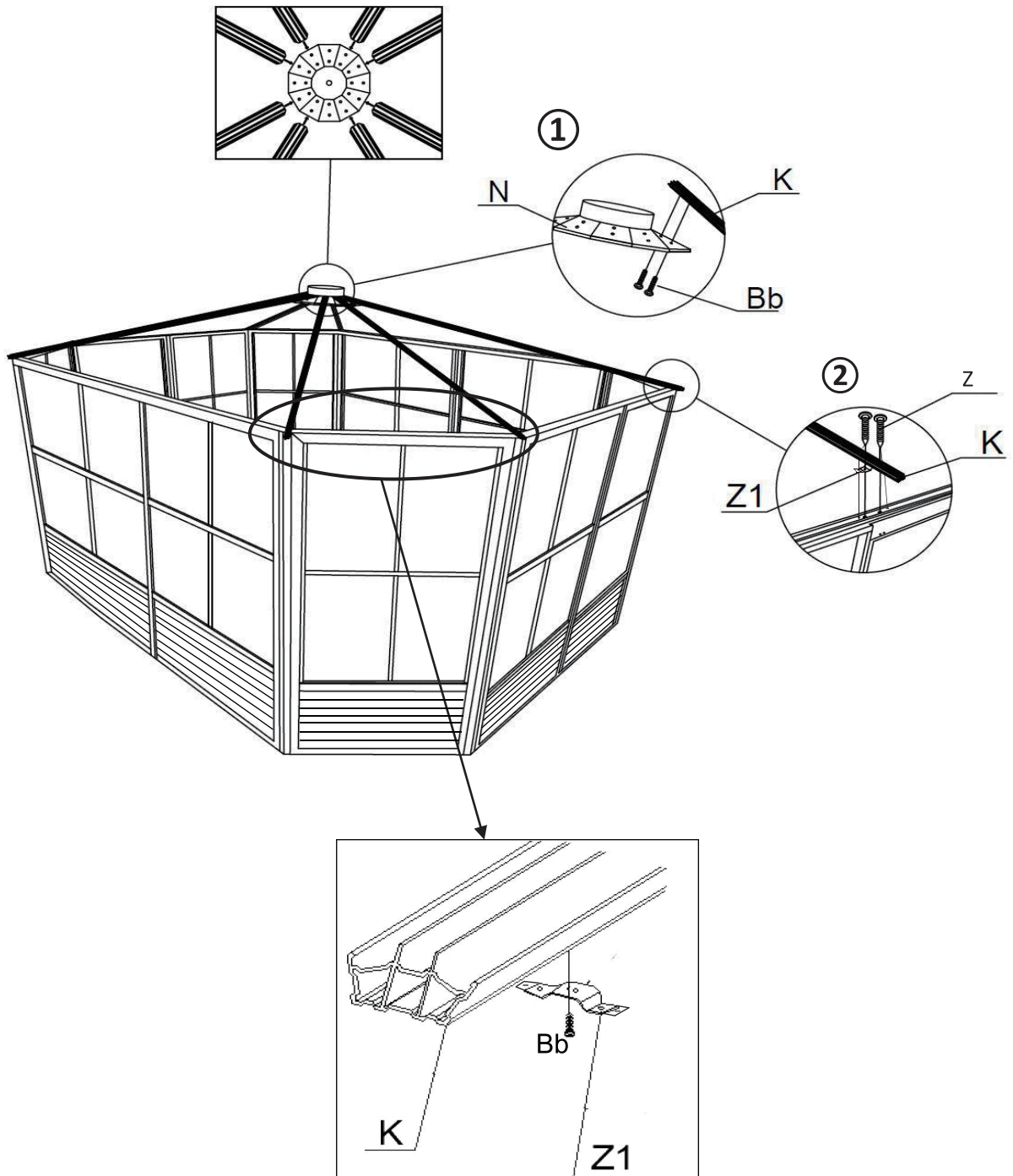

**Step 6:**

1. Assemble steel angle (Z2) to roof Raers (L) using Bolts (Bb).
2. Follow the same procedure of Rafter (K) to assemble roof Rafters (L) onto the remaining panels.

**Note: Do not tighten the bolts right away as you may have to adjust the angle when inserting the roof panels. Then tighten all screws.**

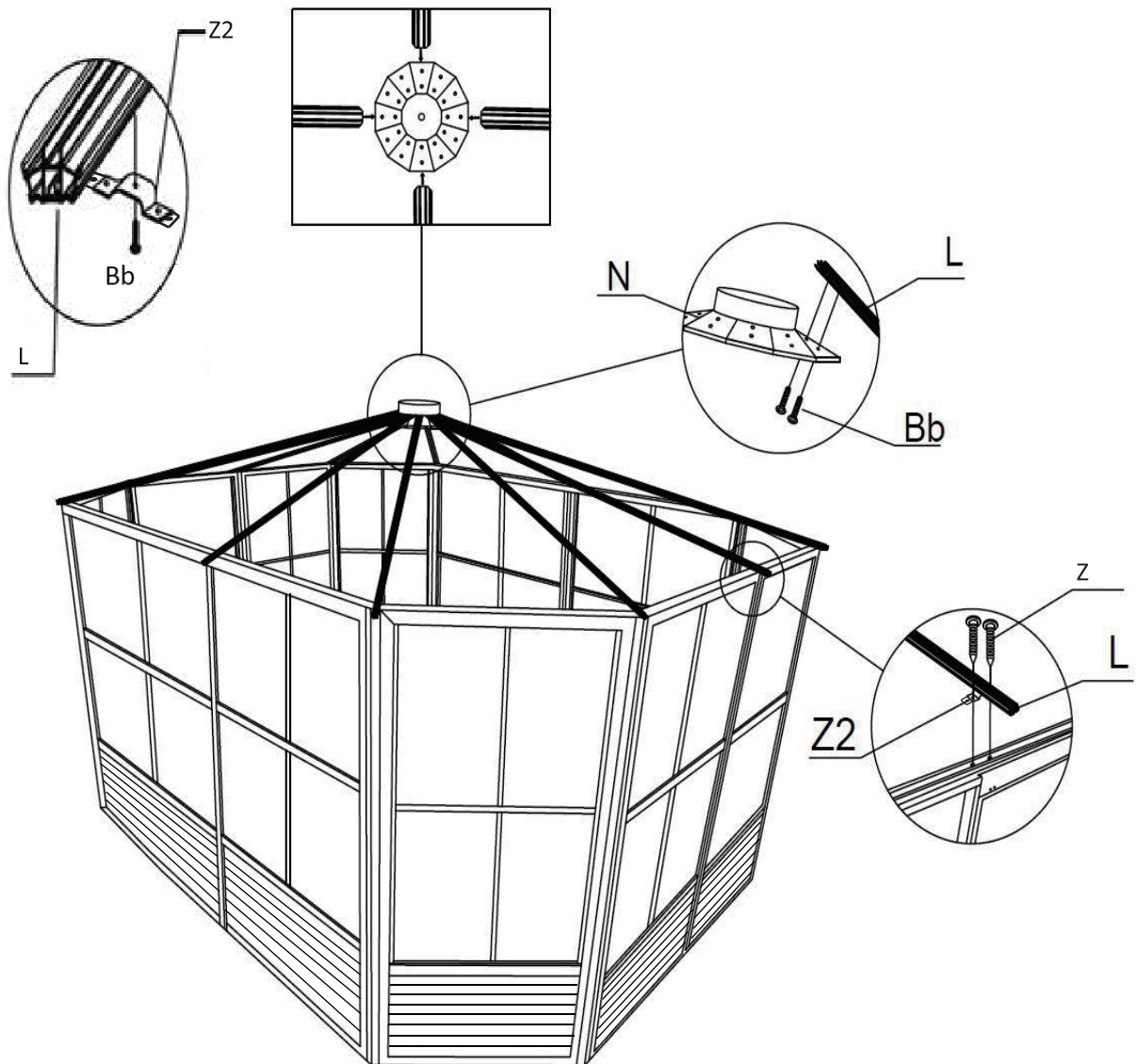

**Step 7:**

1. Now secure the sides of the roof with Finishing Bar (S, U, and U1) with Bolts (Bb) and Brackets R.
2. Place roof Finishing Bars (S, U, and U1) on the right of the Roof Finishing Bar (S, U, and U1) and align the holes in each bar one on top of the other. Place End Caps (R) under the aligned holes and secure with Bolts (Bb).
3. Repeat the process with the remaining finishing bars as illustrated.
4. In order to finish the installation of the last Finishing Bar (S, U, and U1) you have to unscrew the first Bolts (Bb) at your starting point and place an End Cap (R) then re-install the Bolts (Bb).

**NOTE : Make sure all screws/ bolts are tight, when finished assembling.**

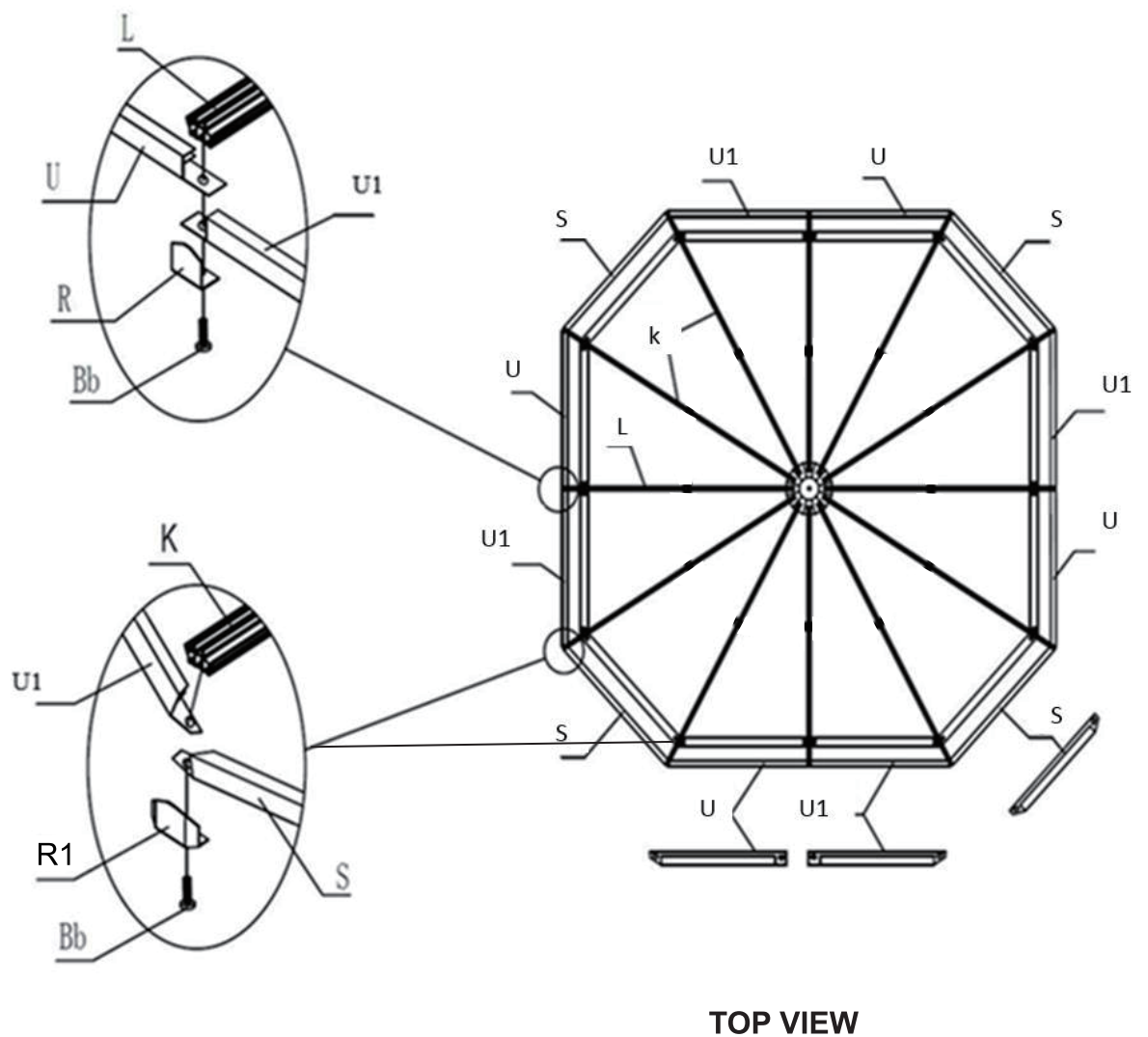

**Step 8:**

1. From the inside of the solarium, install all the Brackets (Pp) using Bolts (Bb) on the Rafters L.
2. From the inside of the solarium, install all the Brackets (Pp-1) using Bolts (Bb) on the Rafters K.
3. From the inside of the solarium, install the Solidifying Bar (T, V, and V1) as illustrated using the Bolts (Bb).

**NOTE :** Make sure all screws/ bolts are tight.

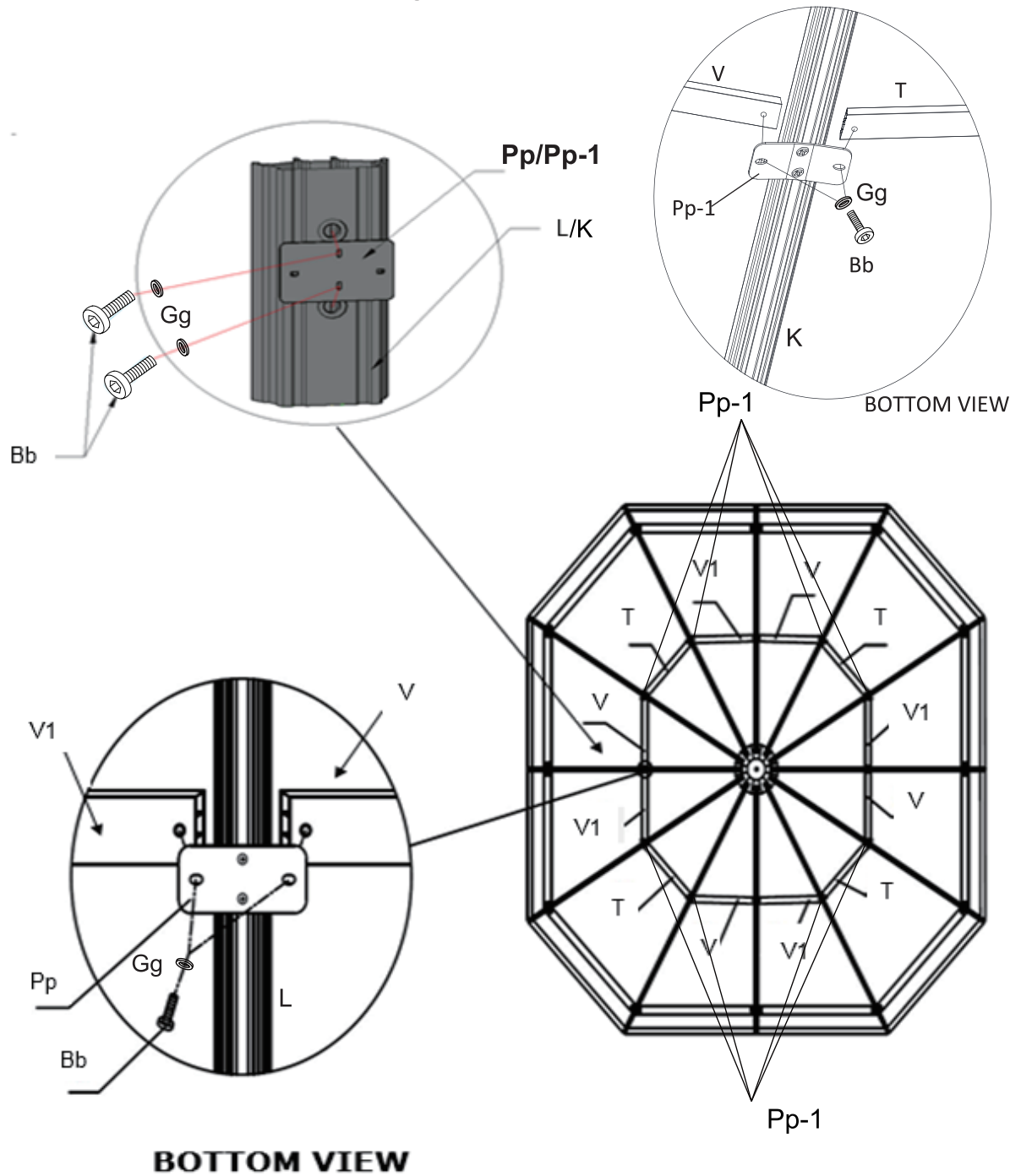

**Step 9:**

1. Install the bottom Roof Panels (Jj, Kk, and Mm) by sliding them onto Finishing Bar (S, U, U1).

**NOTE:**

1. Please refer to the stickers on how to place the roof panels.
2. Make sure all screws/ bolts are tight.

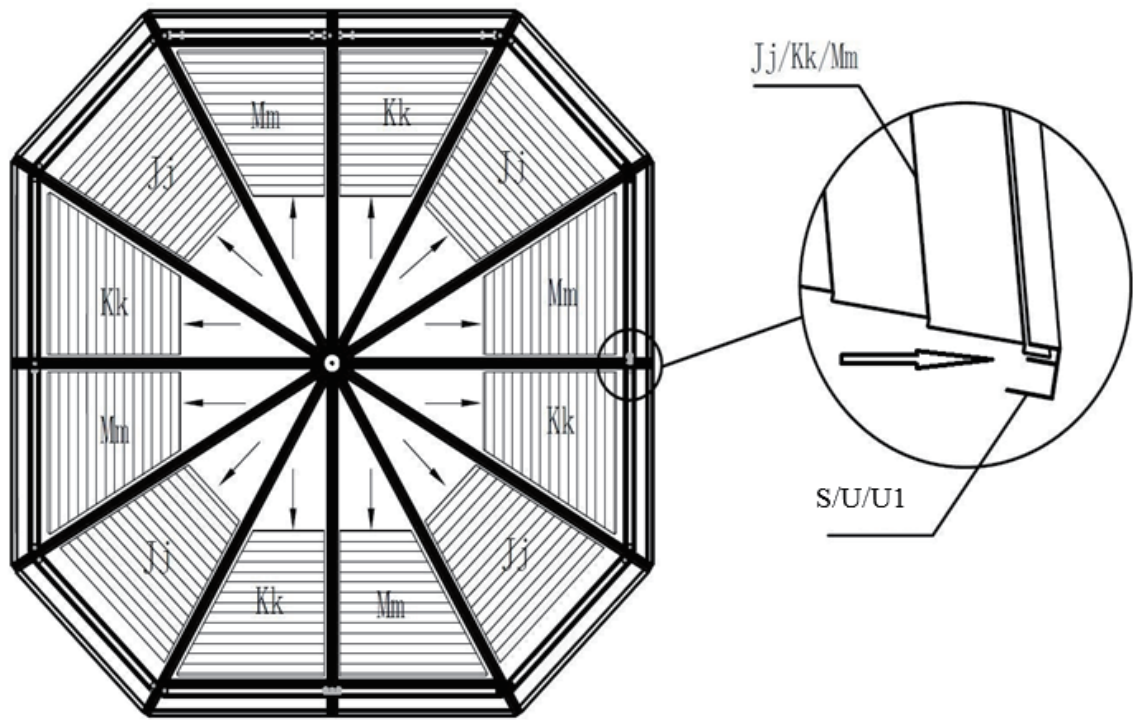

**TOP VIEW**

**Step 10:**

1. Install the upper Roof Panel (Aa) by sliding them on top of roof Rafters (K).

**NOTE:** Please refer to the stickers on how to place the roof panels.

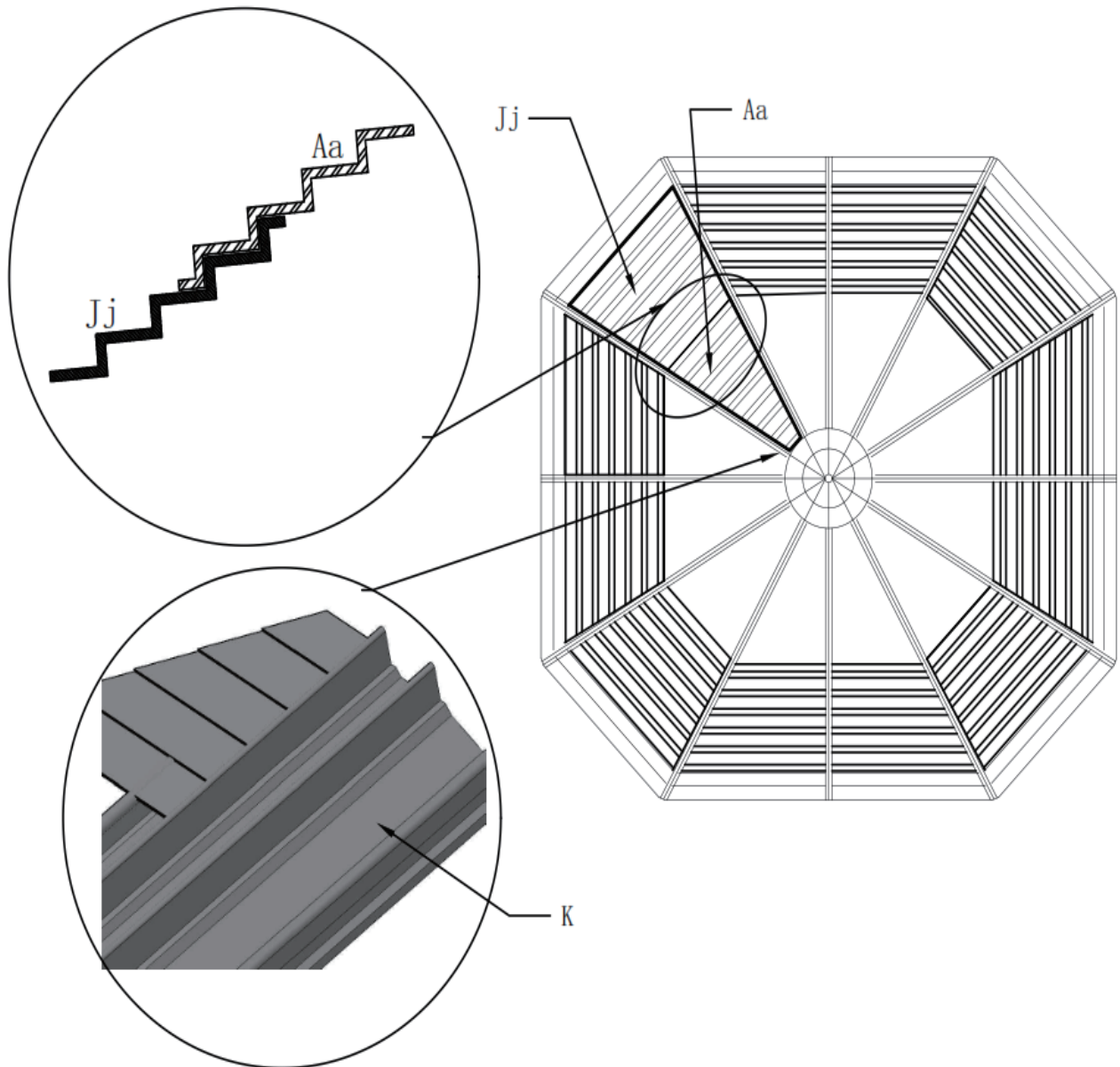

**Step 11:**

1. Once installation of the Roof Panel (Aa) is complete, affix it using the Cover for Rafters(0) using the Screws (Oo1) on one side only, then place another roof panel and repeat step until last roof panel is installed using all Cover for Rafters (0 & 01).

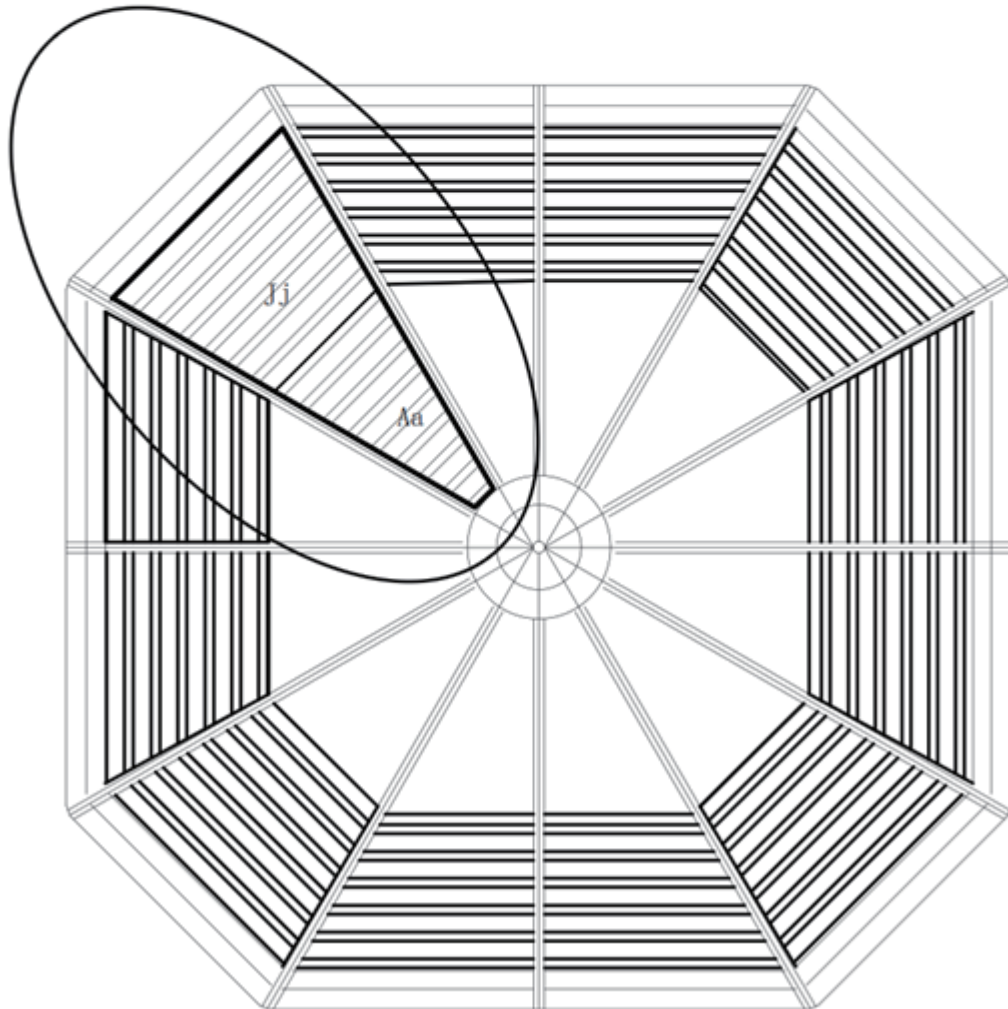
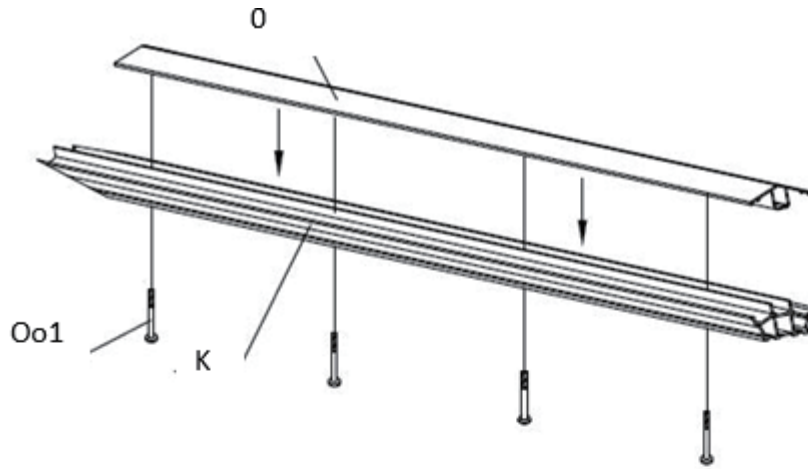

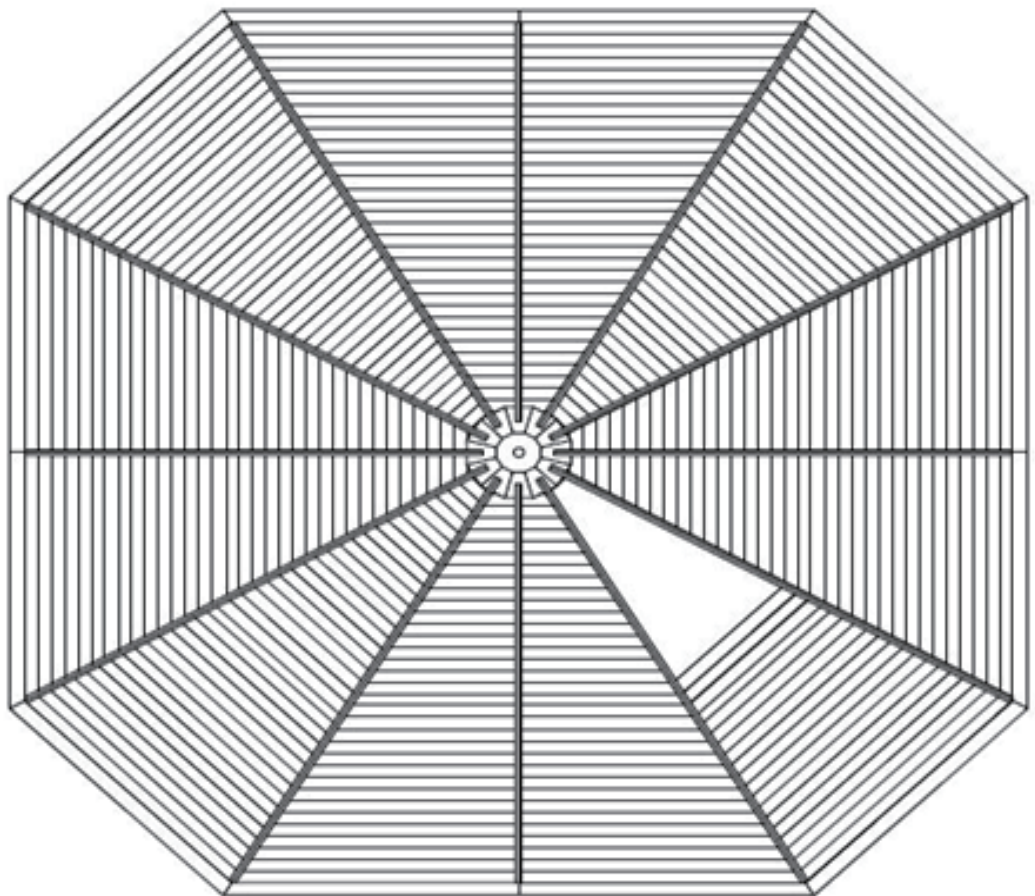
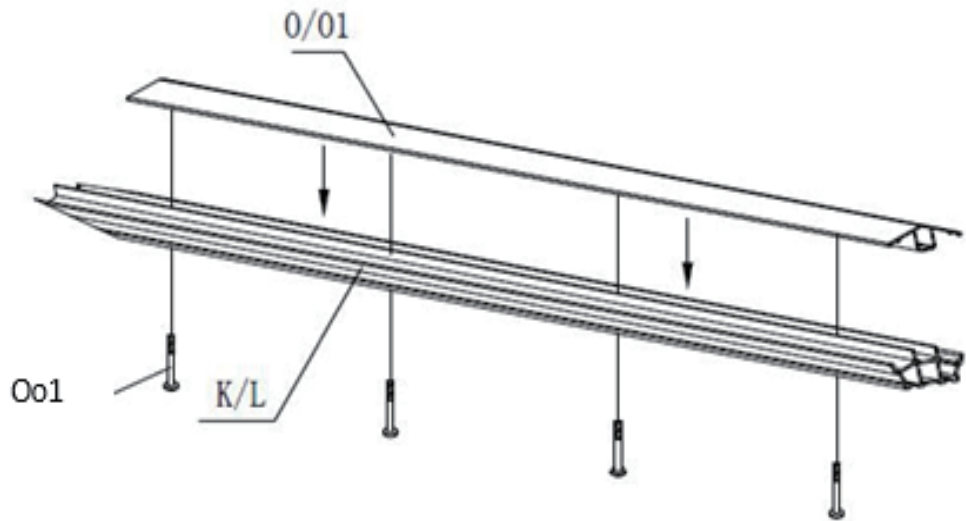

**Step 12:**

1. Put Top Cap (M) on top of the Central Hub (N).

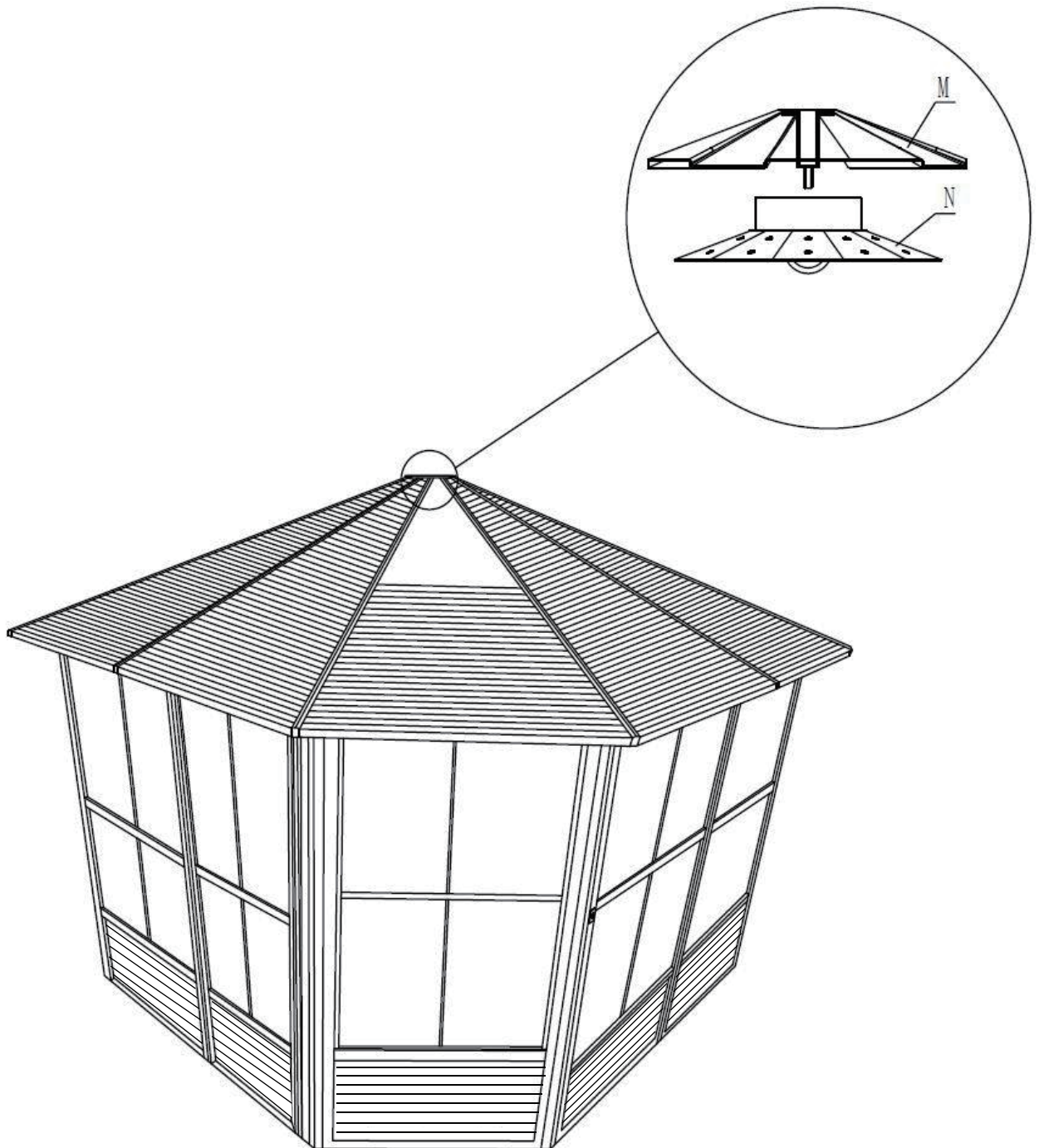

**Step 13:**

1. Install the last Roof Panel (Aa).

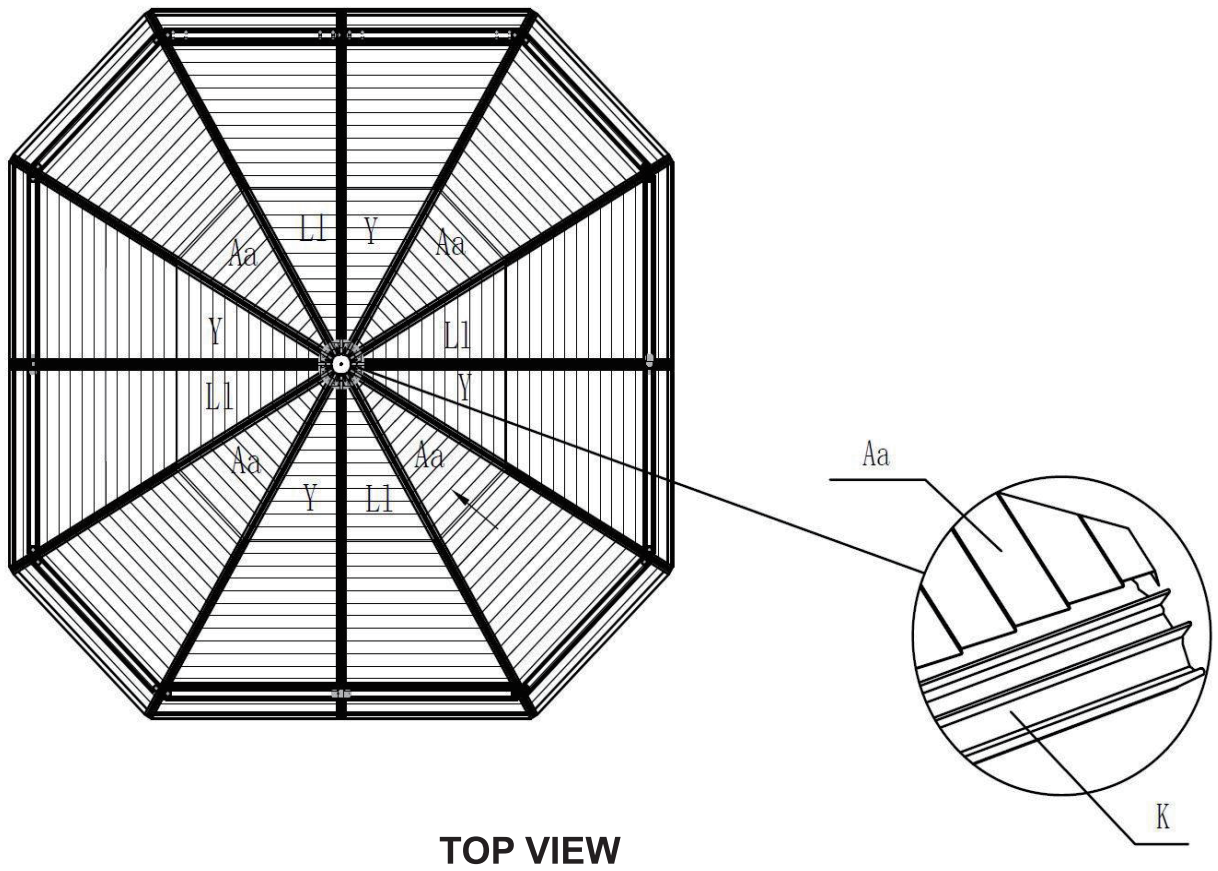

**Step 14:**

1. Once the last roof panel is installed, screw last Cover for Rafters (O) to the Rafter (K) with bolts (Oo1).

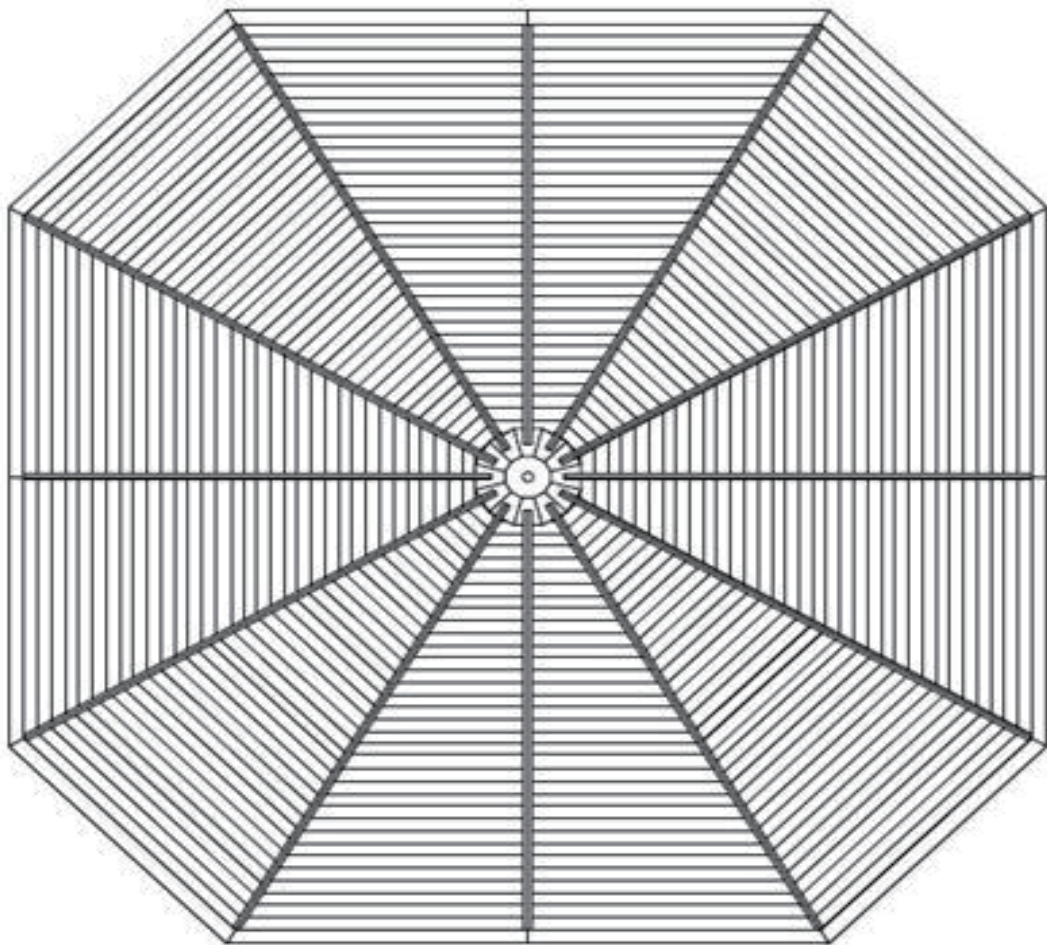
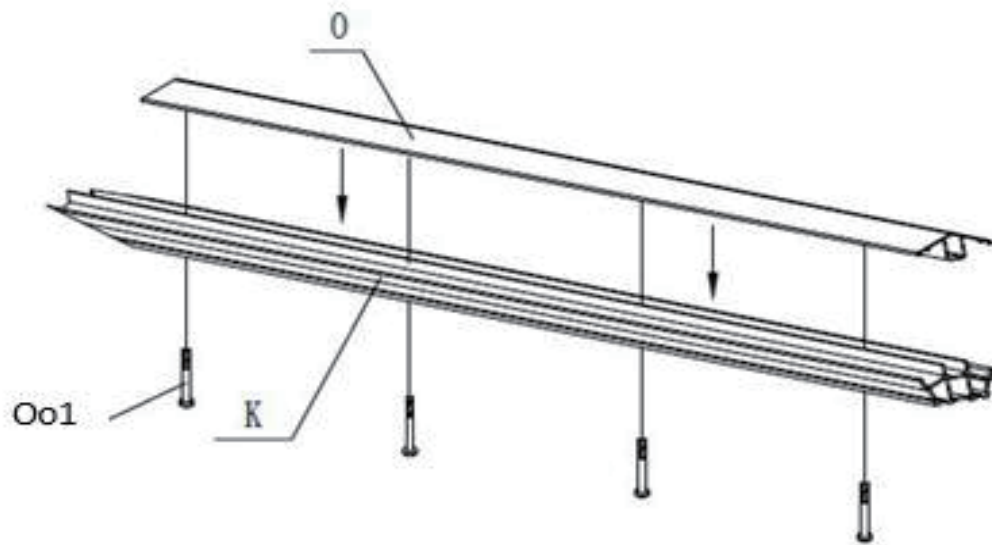

**Step 15:**

1. Use Acorn Nut (Hh) and Washer (Gg) to affix the Top Cap (M) to the Central Hub (N).

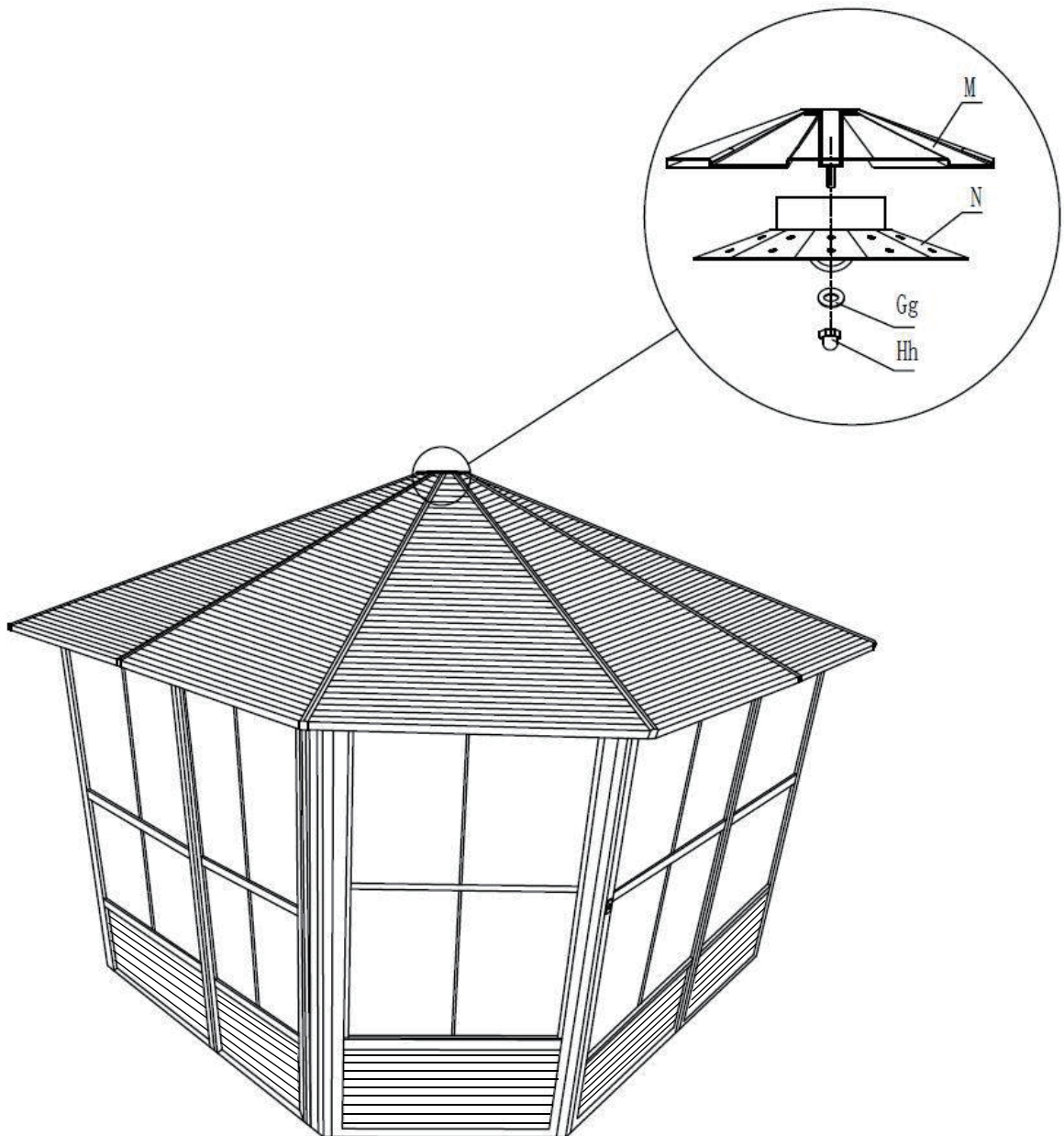

## **\*Suggestions**

The below mentioned are only suggestions in order to permit drainage, these will vary depending on your flooring – material, flatness and slope.

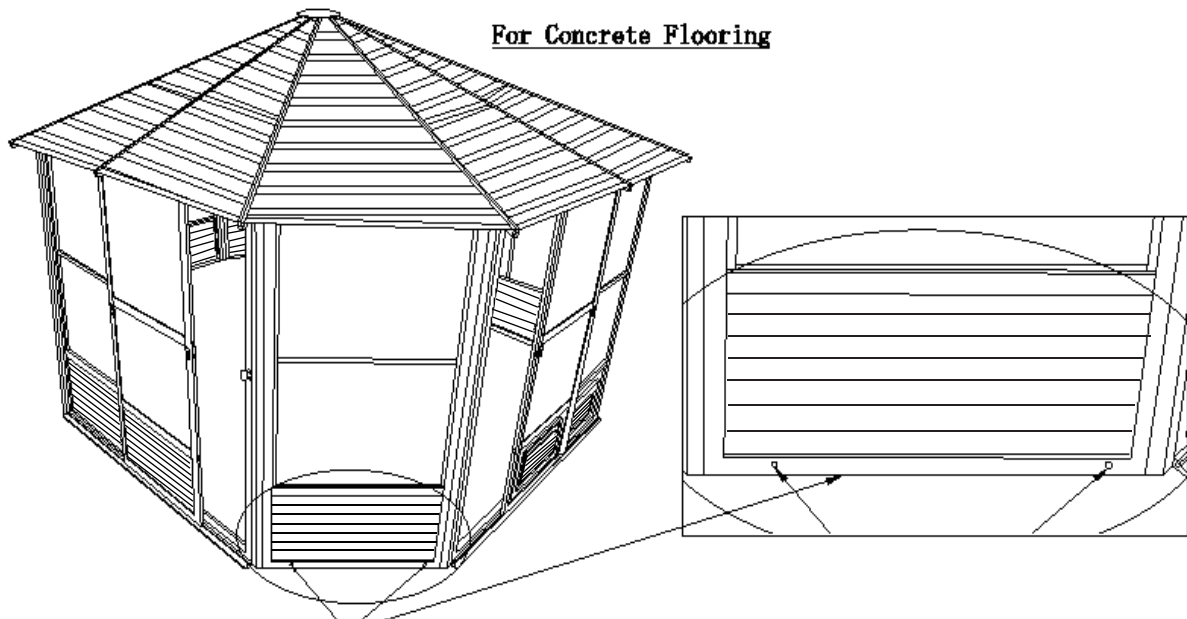

On the outside face, it is suggested to drill holes at the bottom end of the panels to permit drainage when installing on Concrete floor

## **For Wooden Deck**

**Drill through the wooden deck  
where drain holes are located to  
permit drainage**

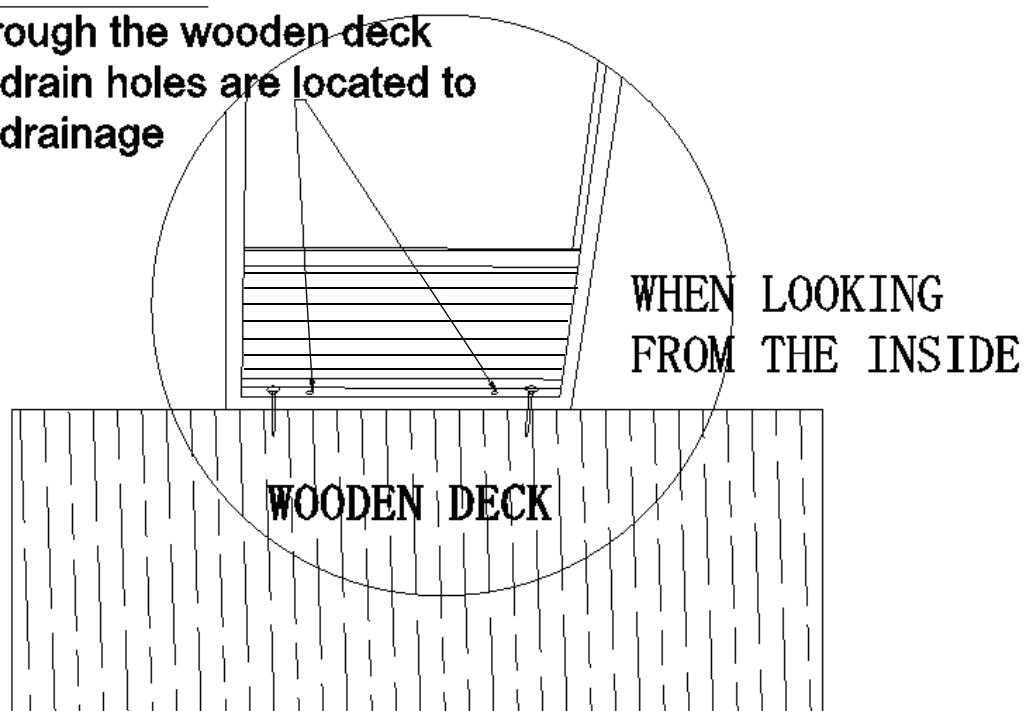

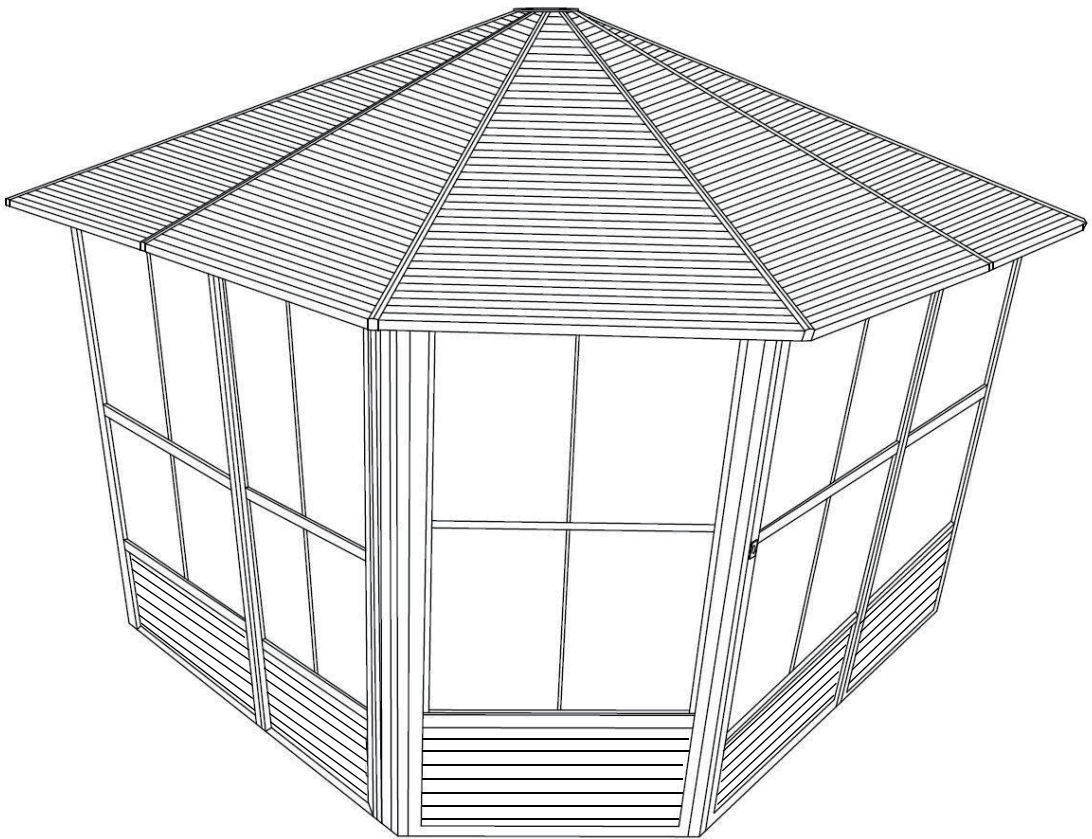
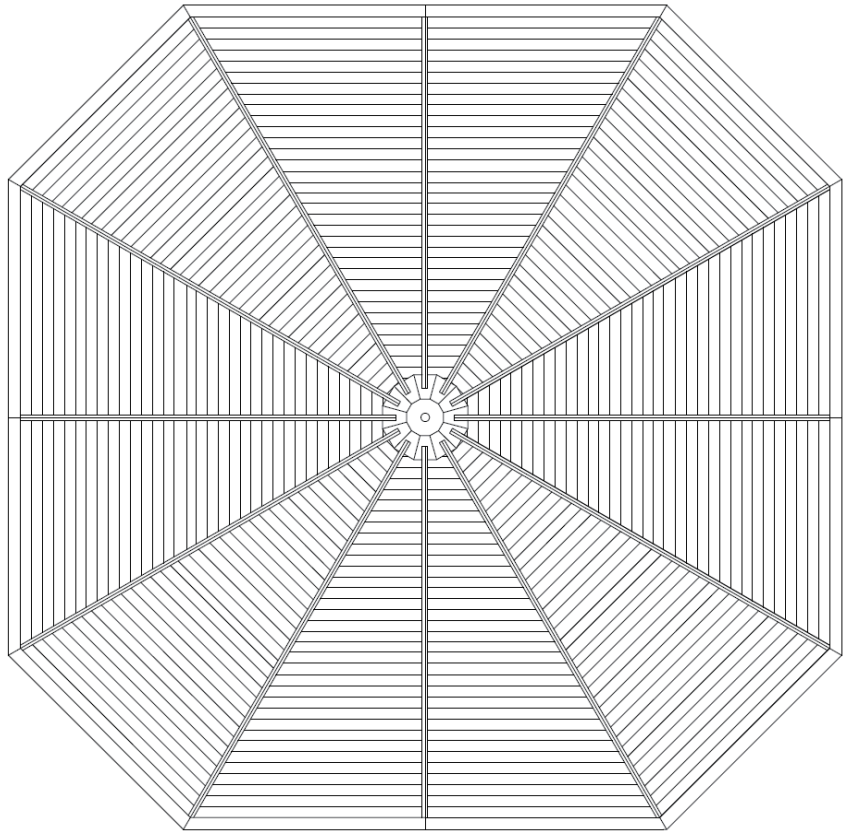

# WARRANTY

Carefully inspect the contents of the package to check if any components are missing or damaged. In the event that any parts are missing or damaged, **do not return the product to the place of purchase; instead, contact Gazebo Penguin's Customer Experience Department.**

**Montreal: (514) 276-3485**

**Elsewhere in Canada and the United States: 1-800-737-7174**

**info@gazebopenguin.com**

This product has been designed and manufactured to meet the highest standards of quality and durability. It is warranted against defects in material and/or workmanship as subjected in the «Warranty Limitations and exclusions» listed below:

- 1 YEAR ON MANUFACTURING DEFECTS

In the event that the product is damaged or the warranty period has expired, please contact Gazebo Penguin's Customer Experience Department for a complete list of replacement parts and prices.

## WARRANTY LIMITATIONS AND EXCLUSIONS

- 1. Uncovered Damages:** This warranty does not cover damages caused by wind, falling objects, fire, animals, vegetation, vandalism, extreme weather conditions, or collapses due to the accumulation of snow and/or ice.
- 2. Roof Maintenance:** The roof must remain free of snow and ice accumulation. Such accumulation must be removed in five-foot (5') sections from right to left. Damages resulting from lack of roof maintenance are not covered under the warranty.
- 3. Snow and Ice Removal:** Removing snow or ice from inside the product is prohibited, as it may damage the product.
- 4. Positioning:** It is advised not to place the product near buildings or trees, as snow and/or ice may slide off and accumulate on the roof, causing excessive weight.
- 5. Installation:** The warranty is valid only if the product is installed according to the instructions provided by Gazebo Penguin. Improper installation, including inadequate anchoring, voids the warranty..
- 6. Water Infiltration:** Water infiltration may occur during heavy rains. Refer to the instruction manual for window positioning and information on water drainage.
- 7. Replacement Clause:** We reserve the right to repair or replace any defective product or part at our sole discretion.
- 8. Modifications:** Any modification or addition to the product voids the warranty.