



MANUEL D'INSTRUCTIONS

INSTRUCTION MANUAL

Florence Solarium 12 Pl. X 18 Pl. - Toit d'Acier
Florence Solarium 12 FT. X 18 FT. - Metal Roof

sku: 41218MR-GP-12		
sku: 41218MR-GP-32		
sku: 41218MR-GP-42		

**DE NE PAS DÉTRUIRE LES BOÎTES AVANT FINIR L'INSTALLATION AU COMPLET
POUR LA RÉFÉRENCE FUTURE, PRENEZ DES PHOTOS DE TOUS LES SIX CÔTÉS DE
CHACUNE DES BOÎTES À LA RÉCEPTION DU PRODUIT.**

SVP, VÉRIFIEZ LE CONTENU DE CHAQUE BOÎTE VS LA LISTE DES PIÈCES DÉTAILLÉE

12pi x 18pi / 3.66m x 5.49m Meters Solarium

LES INSTRUCTIONS D'INSTALLATION

IMPORTANT: RETENIR POUR LA FUTURE RÉFÉRENCE, LIRE ATTENTIVEMENT

Consultez votre autorité locale / les codes municipaux locaux concernant l'installation de structures temporaires avant l'achat ou l'assemblage. Certaines juridictions peuvent exiger des permis pour, ou réglementer autrement, l'installation et l'utilisation.

Pour l'assistance de l'assemblage, d'installation, des pièces en particulier, ou service à la clientèle, veuillez contacter Gazebo Penguin au numéro de téléphone mentionné mi-bas : (français, anglais, lun. à ven. de 8 du matin à 4 après-midi est) :

Montréal: (514) 276-3485

Canada et États-Unis: 1-800-737-7174

ATTENTION:

- Pour une utilisation à l'extérieur.
- La neige doit être nettoyée en tout le temps, de ne pas laisser s'accumuler.
- Retenir votre **preuve d'achat** pour la garantie. Veuillez **garder les boîtes** jusqu'à d'avoir fini l'installation correctement au complet.
- D'assemblage peut durer plus que 4 heures et l'exige d'avoir au moins 3 personnes.



AVANT ASSEMBLAGE:

- Veuillez ne pas détruire les boîtes avant d'avoir fini complètement l'assemblage.
- La fondation doit être sous le niveau de sol, plat et solide, comme du béton ou de l'asphalte.
- Tenez à l'écart des lignes électriques aériennes, des branches d'arbres et d'autres structures.
- Vérifiez s'il y a des tuyaux ou des fils souterrains si le creusement ou le forage est nécessaire.
- Ne pas installer à proximité des lignes de toit ou d'autres structures qui pourraient jeter de la neige, de la glace ou une pluie excessive sur le toit.
- Assemblez la structure près du point final d'utilisation la plus proche possible.
- Il est recommandé de porter des gants de sécurité, des lunettes de sécurité et des casques de protection pour l'installation.
- Ne vous suspendez pas, ne grimpez pas et ne vous tenez pas debout sur la structure ou le toit.
- Avant le montage, lisez les instructions et vérifiez que toutes les pièces sont présentes dans les boîtes. S'il manque des pièces, svp, contactez notre département de garantie.
- Un escabeau de 6 pieds (1,8 m), un tournevis Phillips, un ruban à mesurer, un niveau, un maillet et une bâche sur laquelle placer les pièces seront nécessaires pour l'assemblage (non inclus).
- Enlevez le film protecteur supérieur des panneaux de toit avant l'assemblage; NE PAS retirer le film protecteur inférieur avant d'être prêt à insérer les panneaux de toit, afin d'identifier le côté supérieur.

INSTRUCTION D'ANCRAGE:

- Un ancrage adéquat du cadre à la base et au mur est nécessaire pour la sécurité.
- Une structure non solidement ancrée a un risque de s'envoler lors de vents violents causant des dommages et des risques pour la sécurité.
- Le matériel et les outils requis pour l'ancrage varient en fonction de l'emplacement d'installation et ne sont pas fournis.
- Veuillez vérifier auprès de votre quincaillerie locale les ancrages appropriés à votre surface.
- Ne pas ancrer aux pavés / dalles de chaussée car ils ne constituent pas une fondation solide.

SOIN ET MAINTENANCE:

- En cas de pièce défectueuse ou endommagée, ou pour toute autre question concernant le produit, veuillez contacter directement le fabricant.
- Veuillez avoir la liste des pièces et les numéros de pièces à portée de main lors de la commande ou de la demande de pièces de rechange.











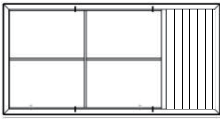
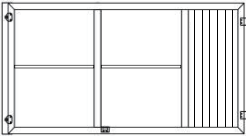

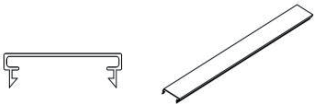
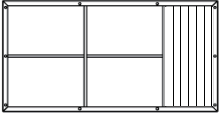
PANNEAUX DE TOIT:





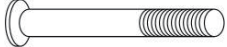





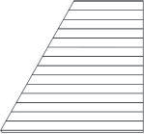
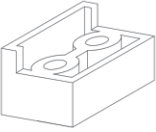
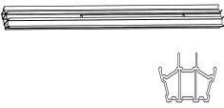
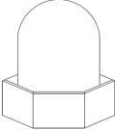
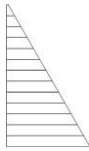

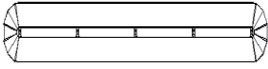
- Nettoyez doucement avec une solution savonneuse écologique et de l'eau à l'aide d'une éponge.
- N'utilisez pas de matériaux abrasifs, de brosses métalliques, de produits chimiques, de nettoyeurs puissants ou d'eau de javel.
- Rincer à l'aide d'un tuyau d'arrosage et sécher à l'air. S'il est retiré, assurez-vous qu'il est complètement sec avant le stockage.
- N'utilisez pas de nettoyeur haute pression.

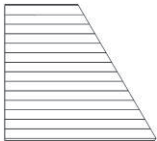

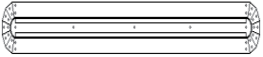

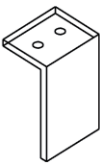

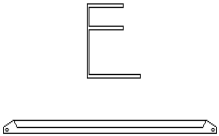

STRUCTURE:



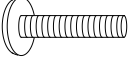
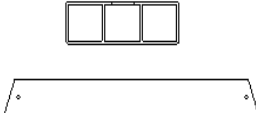
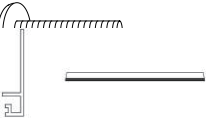
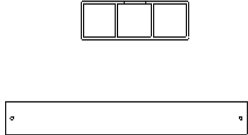
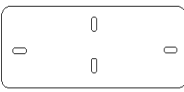

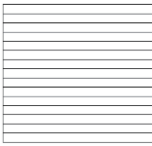

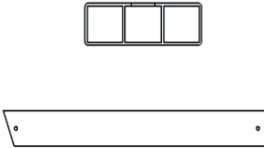
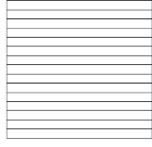
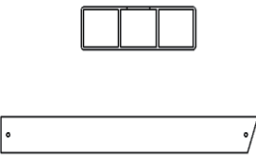
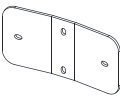
- Nettoyez doucement avec une solution savonneuse écologique et de l'eau à l'aide d'une éponge.
- N'utilisez pas de matériaux abrasifs, de brosses métalliques, de produits chimiques, de nettoyeurs puissants ou d'eau de javel.
- Rincer à l'aide d'un tuyau d'arrosage et sécher à l'air. N'utilisez pas de nettoyeur haute pression.
- S'il y a des imperfections voir le numéro de pièce de la peinture dans la liste des pièces pour obtenir une peinture de retouche correspondante.

12 x 18 Solarium

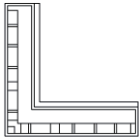

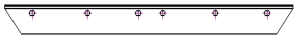

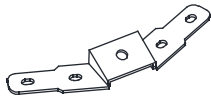
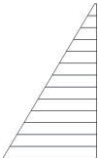
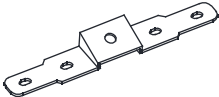

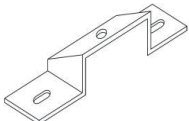

DESCRIPTION	EMBALLE DANS LA BOITE	QUANTITE	SCHEMA	DESCRIPTION	EMBALLE DANS LA BOITE	QUANTITE	SCHEMA
23-086 CADRE REGULIER A	3	4		23-089 CADRE DE PORTE AVEC DE CANAL RÉCEPTEUR D	3	1	
	4	8					
17-054 PANNEAU DE TOIT Aa	1	4		08-133 PIECE DE CONNEXION E	5	14	
23-087 CADRE ADJACENT (trous additionnels) B	3	2		23-215 Clé Hexagonale QQ	5	1	
25-114 VIS M6*16 Bb	5	140		08-162 RAIL DE PORTE SUPÉRIEUR 81.9" F	5	1	
23-088 PORTE COULISSANTE C	3	1		08-221 RAIL DE PORTE SUPÉRIEUR 81.9" F1	5	1	
25-115 VIS M6*73 Cc	5	12		08-163 RAIL DE INFÉRIEUR 81.9" G	5	1	
25-117 ECROU M5*60 Cc-2	5	12		08-220 RAIL DE INFÉRIEUR 81.9" G1	5	1	

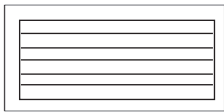
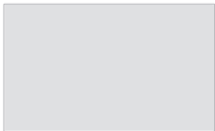
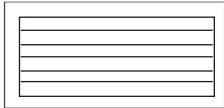
DESCRIPTION	EMBALLÉ DANS LA BOITE	QUANTITE	SCHEMA	DESCRIPTION	EMBALLÉ DANS LA BOITE	QUANTITE	SCHEMA
08-187 RONDELLE Gg	5	73		17-061 PANNEAU DE TOIT Kk	2	4	
08-138 BUTOIR PORTE H	5	2		17-044 CHEVRON 78.9" L	5	8	
08-189 ECROU Hh	5	5		17-057 PANNEAU DE TOIT LI	2	4	
08-139 PIECE DE CONNEXION 78.9" I	5	8		08-164 CAPUCHON EXTERIEUR M	5	1	
23-223 Clé Hexagonale RR	5	1		17-058 PANNEAU DE TOIT Mm	2	4	
08-140 PIECE DE CONNEXION J	5	8		08-166 CAPUCHON INTERIEUR N	5	1	
17-055 PANNEAU DE TOIT Jj	1	4		08-134 CAPUCHON RAIL DE PORTE SUPERIEUR Nn	5	2	
17-043 CHEVRON 89.9" K	5	8		17-049 BARRE DE TOIT 89.9" O	5	8	
17-050 BARRE DE TOIT 78.5" O1	5	8		17-046 BARRE DE FINITION 45.3" S	5	4	

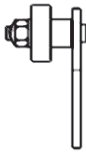
DESCRIPTION	EMBALLE DANS LA BOITE	QUANTITE	SCHEMA	DESCRIPTION	EMBALLE DANS LA BOITE	QUANTITE	SCHEMA
08-135 VIS Oo	5	4		17-068 BARRE DE FINITION 42.6" Ss	5	4	
25-116 VIS M6X36 Oo1	5	64		17-048 BARRE DE SOLIDIFICATION 20.8" T	5	4	
17-051 BARRE DE RECOUVREMENT 39.7" P	5	12		17-069 BARRE DE SOLIDIFICATION 39.4" Tt	5	4	
18-067 SUPPORT DE BARRE SOLIDIFIANTE Pp	5	8		17-045 BARRE DE FINITION 45.2" U	5	4	
17-075 PANNEAU DE TOIT Qq	1	4		17-071 BARRE DE FINITION 45.2" U1	5	4	
17-053 EMBOUT R	5	8		17-047 BARRE DE SOLIDIFICATION 20.8" V	5	4	
17-076 PANNEAU DE TOIT Rr	1	4		17-070 BARRE DE SOLIDIFICATION 20.8" V1	5	4	
23-004 SUPPORT DE BARRE SOLIDIFIANTE Pp-1	5	8		23-005 EMBOUT R1	5	8	

DESCRIPTION	EMBALLE DANS LA BOITE	QUANTITE	SCHEMA	DESCRIPTION	EMBALLE DANS LA BOITE	QUANTITE	SCHEMA
11-599 CLÉ DE COIN Vv (installé dans yy)	3	4		08-156 VIS M5*20 Z	5	96	
25-118 VIS M5*15 Ww	5	12		11-598 BARRE HORIZONTALE POUR CADRE DE PORTE Zz	3	2	
23-003 CHEVRON DE CENTRE DE PORTE P-1	5	4		15-124 ANGLE EN ACIER Z1	5	8	
17-060 PANNEAU DE TOIT Y	2	4		15-125 ANGLE EN ACIER Z2	5	7	
11-597 CADRE DE PORTE VERTICAL 78.7" Yy	3	2		19-102 ANGLE EN ACIER Z3	5	1	

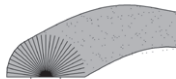
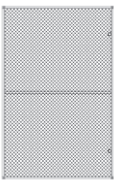
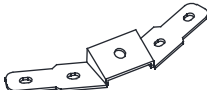
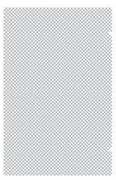
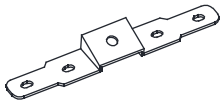
PIÈCES DE REMPLACEMENT DISPONIBLES

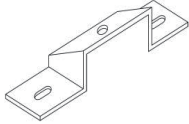
DESCRIPTION	DESSIN	DESCRIPTION	DESSIN
08-219 FENÊTRE PVC (avec cadre)		23-090 PANNEAU ACIER DU BAS (pour murs)	
10-493 FENÊTRE PVC (matériel seulement)		23-091 PANNEAU ACIER DU BAS (pour portes doubles)	
85-417-P ÉCLISSE POUR FENÊTRE PVC		15-097 ROULEAU DE PORTE	
15-123 GOUPILLE POUR FENÊTRE PVC		11-736 CHENAL DE RECEPTION POUR PORTE DOUBLE	
13-054 FENÊTRE PC (pour porte double)		10-458 COUPE-FROID DE REPLACEMENT	
12-046 MOUSTIQUAIRE (avec cadre)		15-124 ANGLE EN ACIER Z1	
85-014 MOUSTIQUAIRE (sans cadre)		15-125 ANGLE EN ACIER Z2	
85-417-S ÉCLISSE POUR MOUSTIQUAIRE		19-102 ANGLE EN ACIER Z3	

***PAS INCLUS DANS LA BOITE**

DESCRIPTION	COULEUR	# DE PIÈCE
PEINTURE À SPRAY	SABLE	11-699
STYLO À PEINTURE		18-245

NOTE: LES DIMENSIONS SONT APPROXIMATIVES.

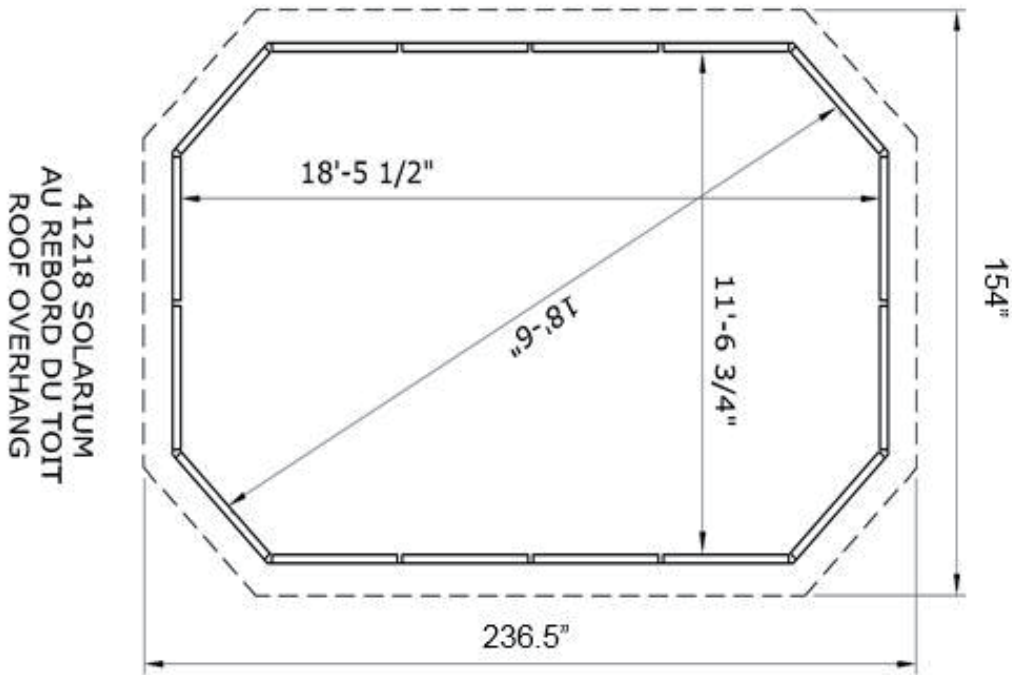
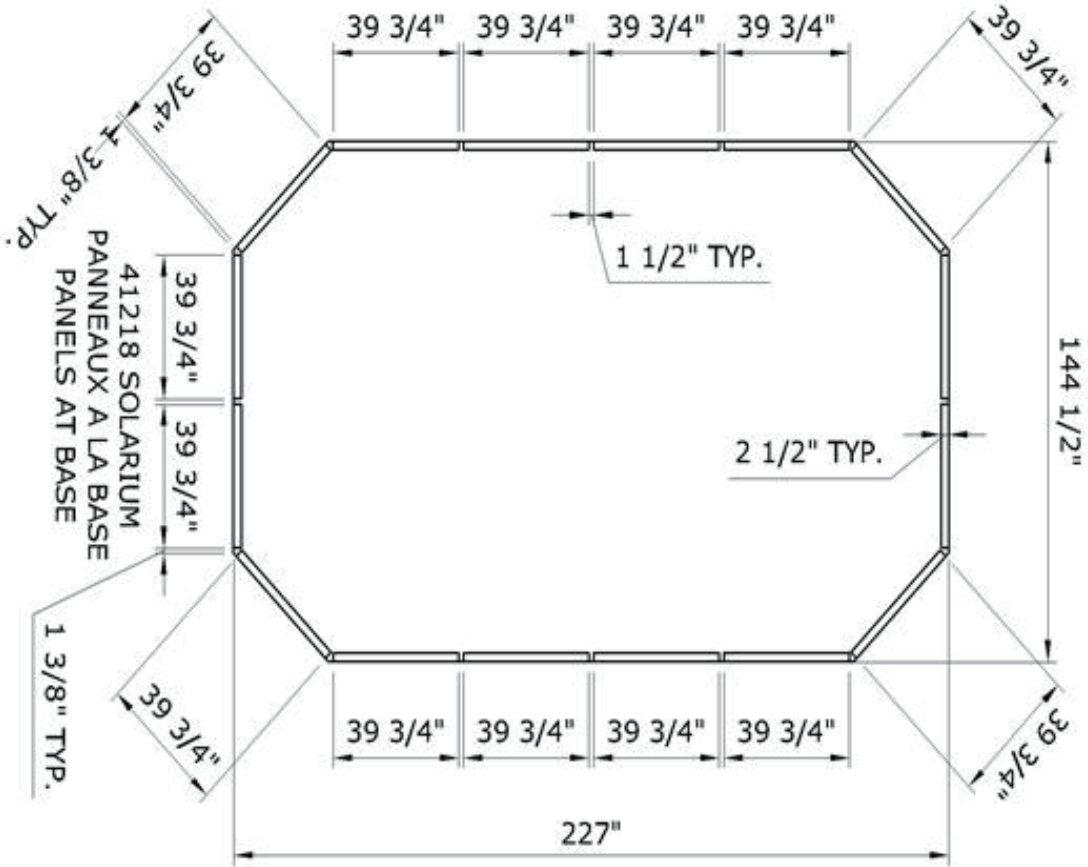

Avant d'assembler le Solarium

- Ne détruisez pas les boîtes tant qu'elles ne sont pas complètement assemblées.
- Pour référence future, prenez des photos des six côtés de chaque boîte dès réception.
- Veuillez comparer chaque boîte à la liste des pièces.

Outils nécessaires :

- Escabeau 6'-8
- Tournevis Phillips #2, Tournevis Robertson #2 (non fourni)
- Maillet en caoutchouc
- Diverses limes
- Perceuse
- Mèche 1/8" pour les trous pilotes

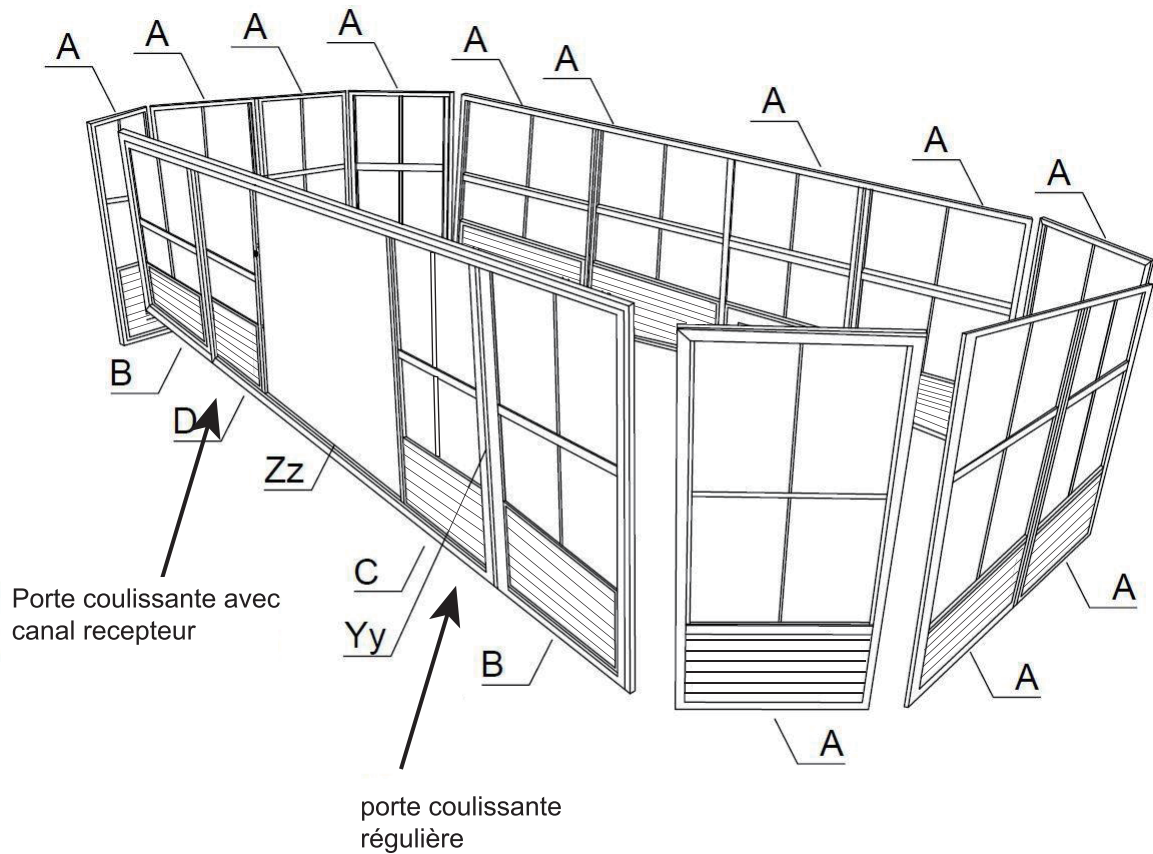

Selon votre emplacement, décidez où vous souhaitez placer les deux (2) panneaux

Étape 2:

1. Attachez les Barres de recouvrement (P) en les faisant glisser sur le dessus de la rainure extérieure des cadres (A, B, D).

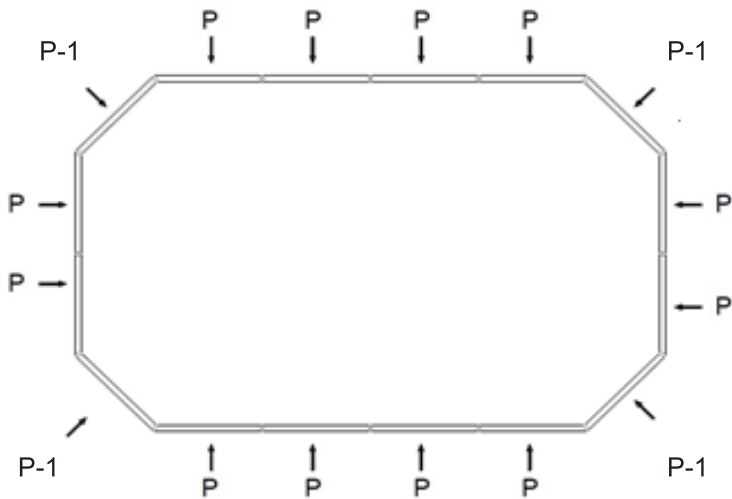
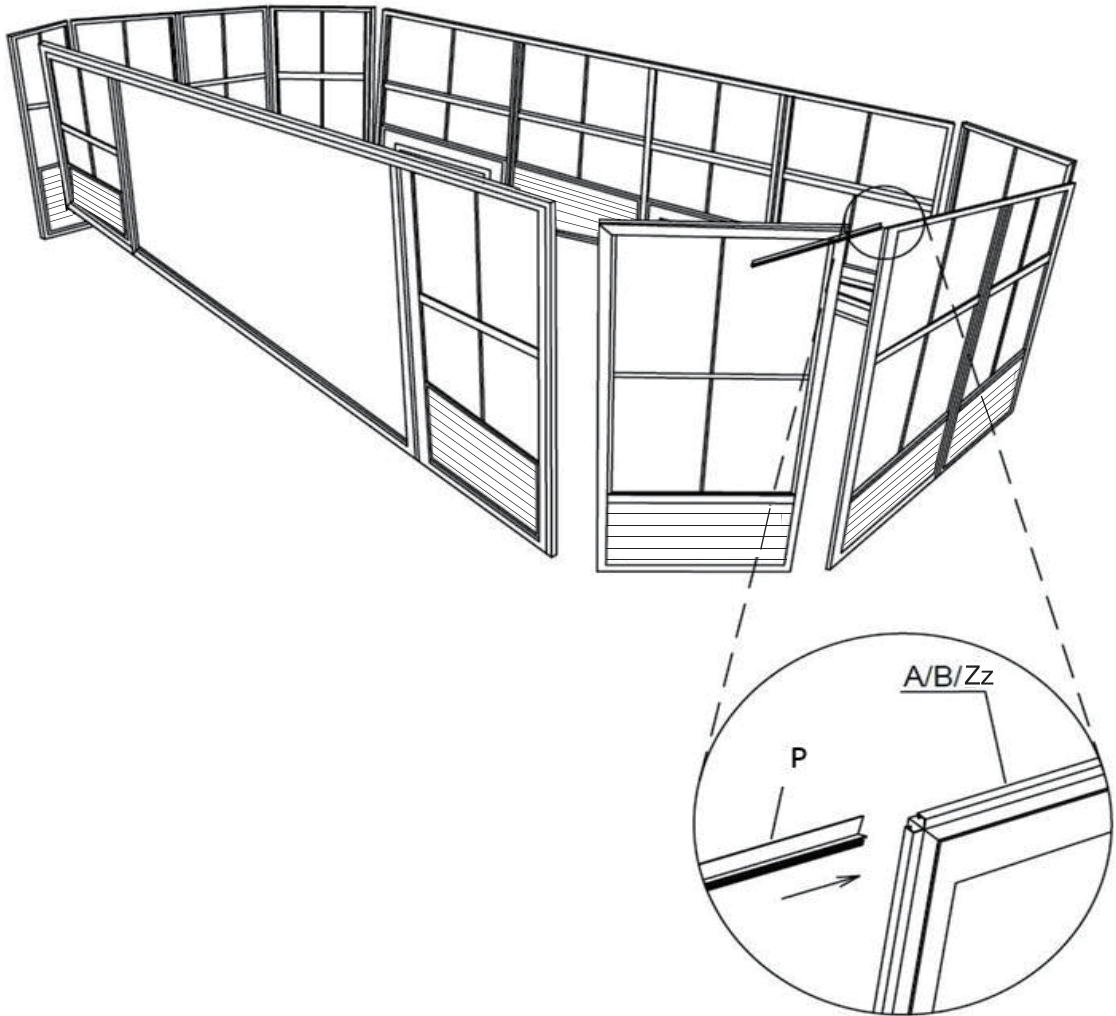

Étape 3:

1. Faites glisser le rail supérieur de la porte (F) dans les roues de la porte coulissante (C).
2. Faites glisser le rail inférieur de la porte (G) dans le guide en plastique de la porte coulissante (C).
3. Utilisez des boulons (Bb) pour attacher les bouchons en plastique (H), un à chaque extrémité du rail supérieur de la porte (F).
4. À l'aide d'une vis (Oo), attachez les capuchons d'extrémité (Nn), un à chaque côté du rail supérieur de porte (F).
5. Procédez de la même manière pour assembler la porte coulissante (D).

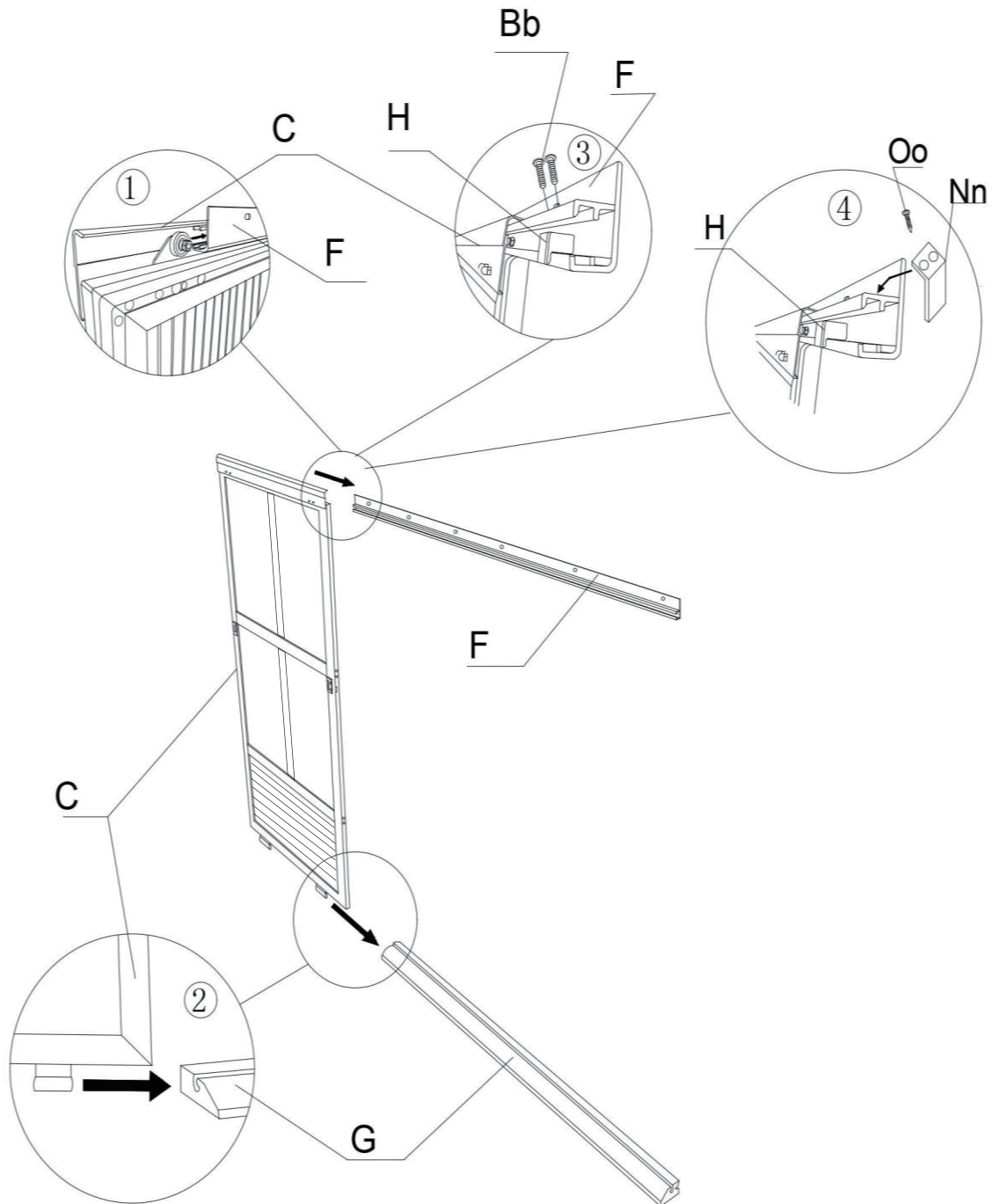

Étape 4:

Veillez noter que nous suggérons d'assembler les portes de l'intérieur du solarium.

1. Placez un boulon (Ww) à travers le cadre supérieur de porte (C) et le rail supérieur de porte (F), et placez un boulon femelle (Cc-2) de l'autre côté. Une fois tous insérés, serrez-les fermement.
2. Sécurisez le rail inférieur de la porte (G) à l'aide d'un boulon (Cc).
3. De même façon suivez des étapes au-dessus pour la porte glissant (D) avec le rail de la porte supérieur (F1) et le rail de la porte inférieure (G1).

Remarque : Ajustez le rail de la porte plus haut pour faciliter le glissement de la porte.

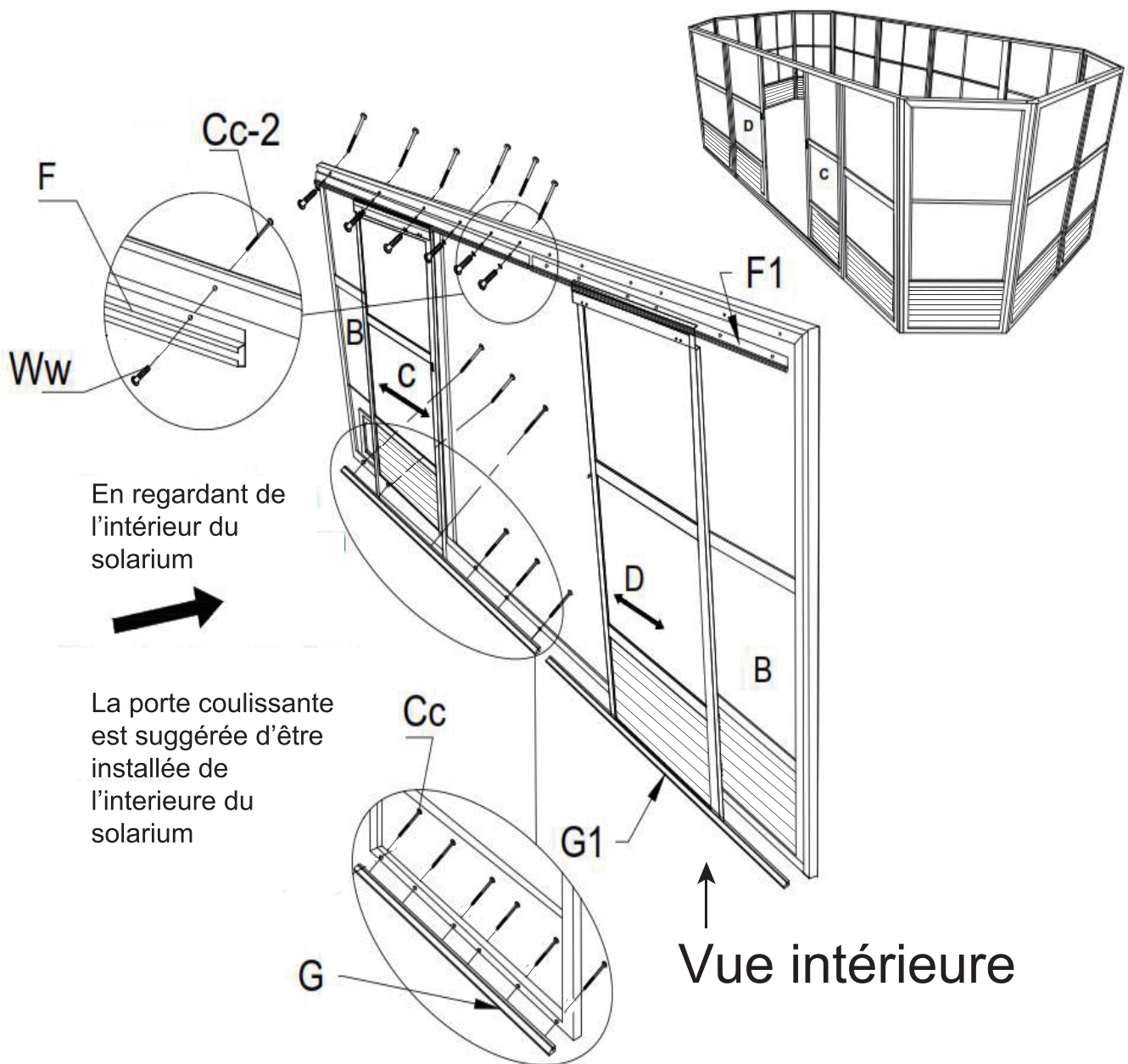

Étape 5:

1. Assemblez la cornière en acier (Z2) aux chevrons du toit (L) à l'aide des boulons (Bb).
Assemblez la cornière en acier (Z3) aux chevrons du toit (L) à l'aide des boulons (Bb).
2. Attachez les chevrons de toit (L, Xx) au moyeu central (N) à l'aide des boulons (Bb).
3. Utilisez les vis (Z) pour fixer les chevrons (L) sur le dessus des panneaux passant par la pièce de métal (Z2) attachée au chevron (L).
4. Utilisez les boulons (Bb) pour attacher le chevron (Xx) sur la barre horizontale pour le cadre de porte (Zz) en haut de l'ouverture de la porte, comme illustré ci-dessous.

Note:

1. Les chevrons doivent être attachés là où les panneaux se connectent les uns aux autres.
2. Le connecteur central est une pièce lourde et nécessite donc un soutien lors de l'assemblage.

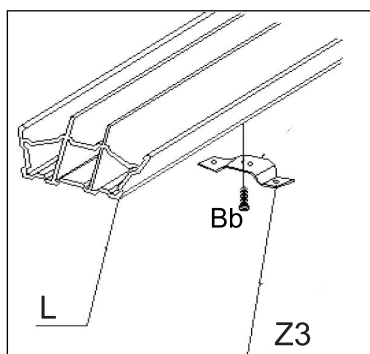
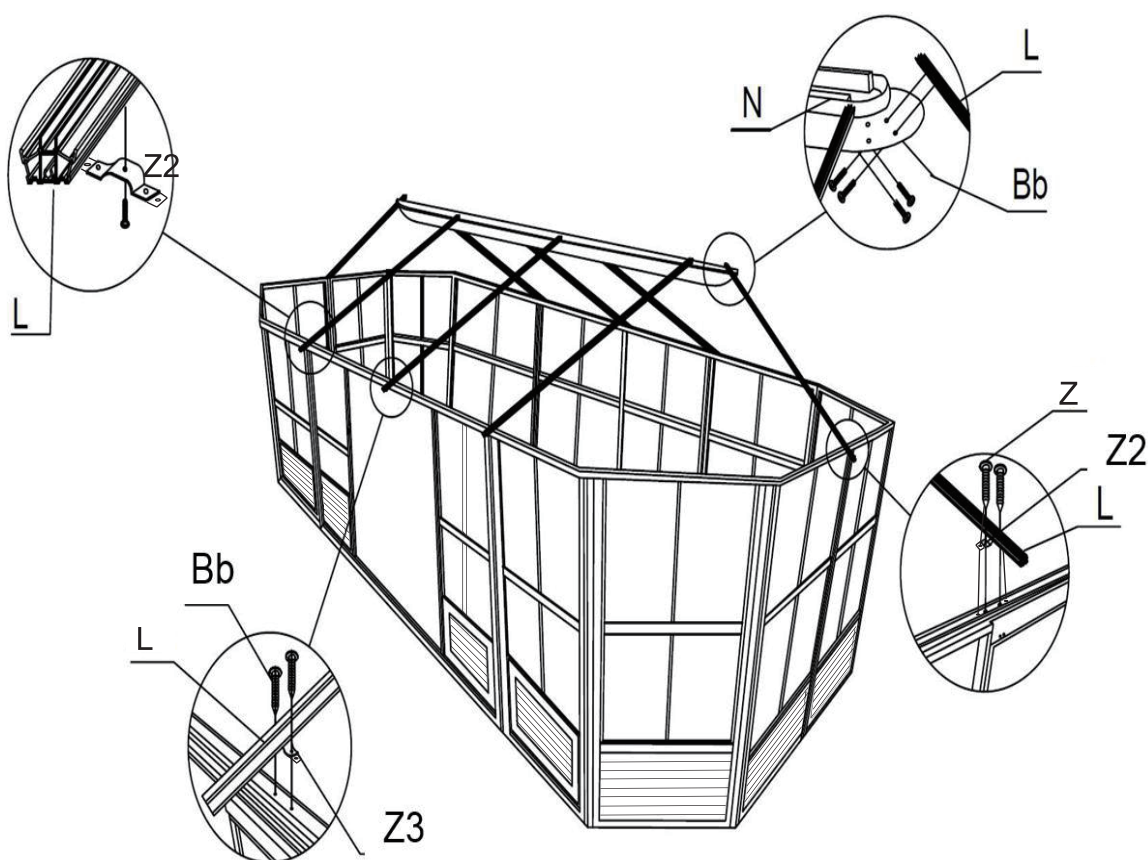

Étape 6:

1. Suivez la même procédure que celle du chevron (L) pour assembler les chevrons de toit (K) sur les panneaux restants.

Note:

1. Les chevrons doivent être attachés là où les panneaux se connectent les uns aux autres.
2. Attachez le chevron (K) de manière à ce que le trou supplémentaire sur le support (Z1) se fasse face comme illustré ci-dessous.
3. Ne serrez pas les boulons tout de suite car vous devrez peut-être ajuster l'angle lors de l'insertion des panneaux de toit.

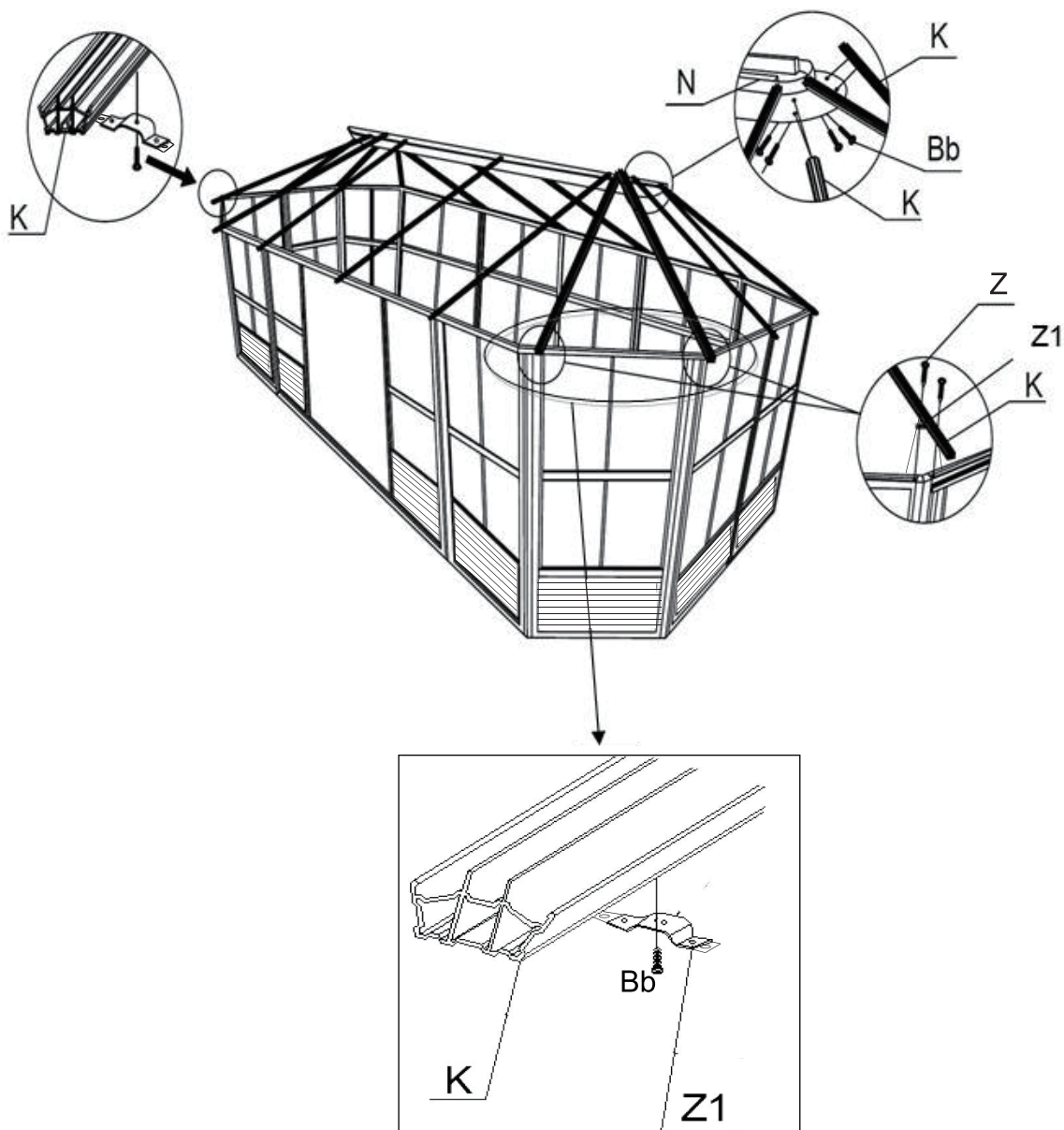

Étape 7:

1. Fixez les côtés du toit avec la barre de finition (S, U, Ss et U1) avec des boulons (Bb) et des supports (R/R1).
2. Connectez les barres de finition du toit (S, U, Ss et U1) les unes aux autres en alignant les trous. Placez les capuchons d'extrémité (R) sous les trous alignés et fixez-les avec des boulons (Bb).
3. Répétez le processus avec les barres de finition restantes comme illustré.
4. Pour terminer l'installation de la dernière barre de finition (S, U, Ss et U1), vous devez dévisser les premiers boulons (Bb) à votre point de départ et placer un capuchon d'extrémité (R), puis réinstaller les boulons (Bb).

Note: Assurez-vous que toutes les vis/boulons sont serrés une fois l'assemblage terminé.

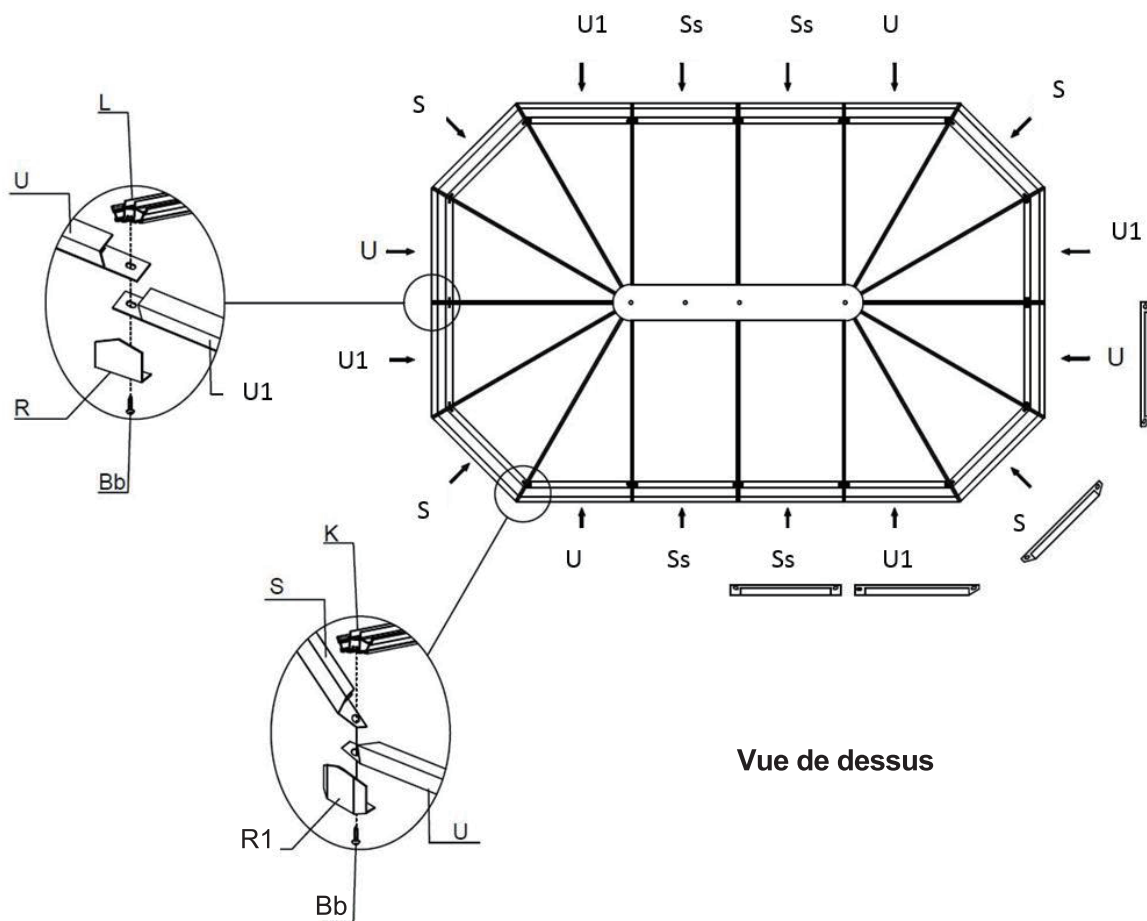

Étape 8:

1. De l'intérieur du solarium, installez tous les supports (Pp/Pp-1) à l'aide des boulons (Bb) sur les chevrons L et K.
2. De l'intérieur du solarium, installez la barre de solidification (T, Tt, V et V1) comme illustré à l'aide des boulons (Bb).

NOTE :

Évitez de les serrer trop fort car cela peut endommager le filetage et la tête.
Assurez-vous que toutes les vis / boulons sont serrés.

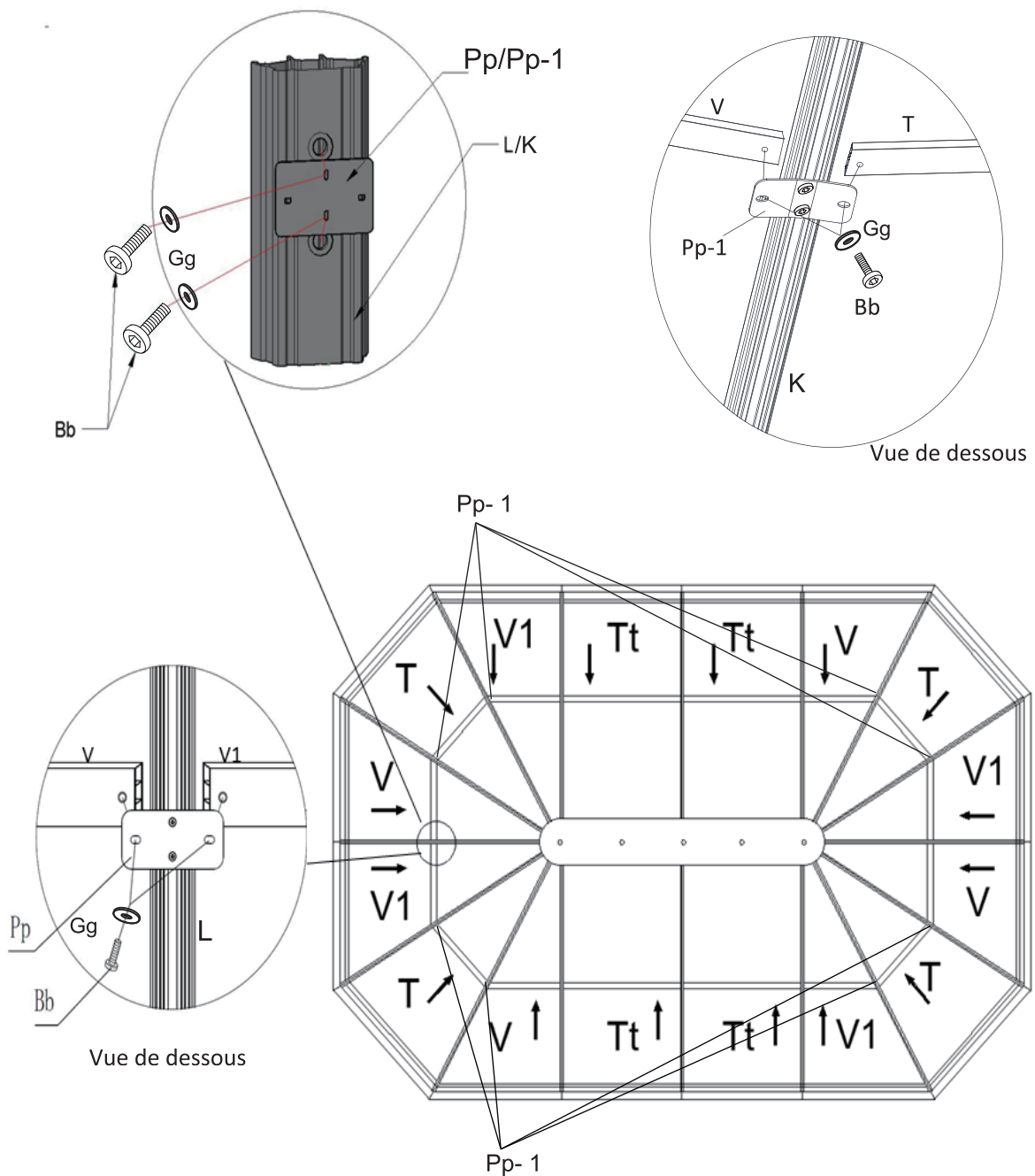

Étape 9:

1. Installez les panneaux de toit inférieurs (Jj, Kk Mm et Rr) en les faisant glisser dans la barre de finition (S, U, Ss & U1).

NOTE:

1. Veuillez-vous référer aux autocollants pour savoir comment placer les panneaux de toit.
2. Assurez-vous que toutes les vis / boulons sont serrés.

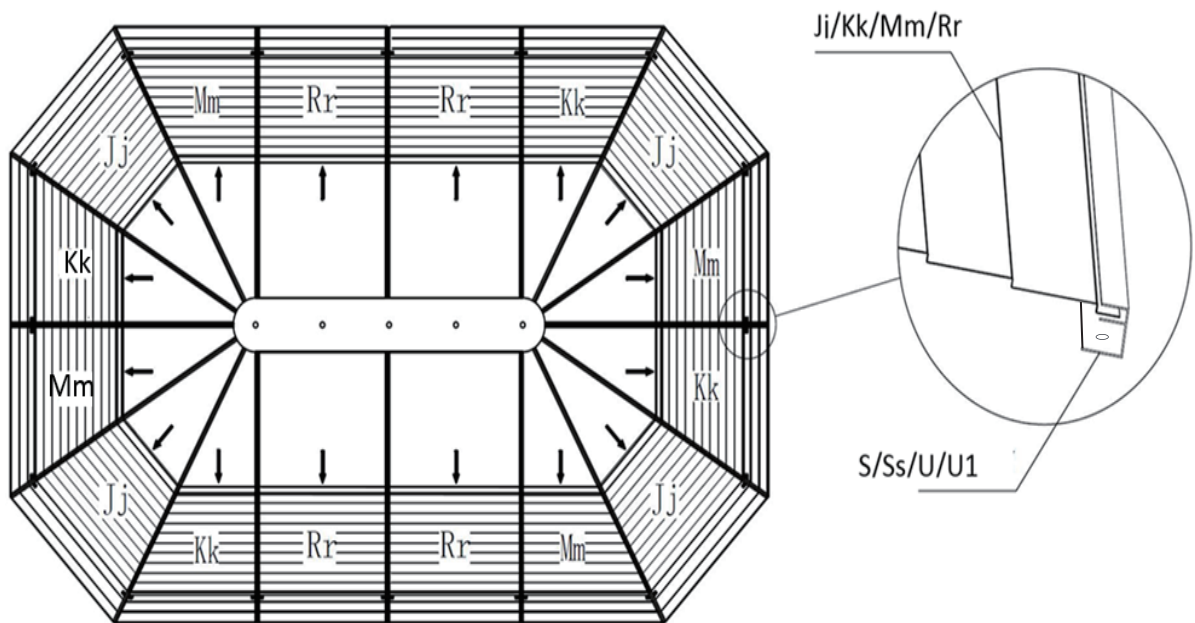

Vue de dessus

Étape 10:

1. Installez le panneau de toit supérieur (Aa) en le faisant glisser sur les chevrons de toit (K).

NOTE: Veuillez-vous référer aux autocollants pour savoir comment placer les panneaux de toit.

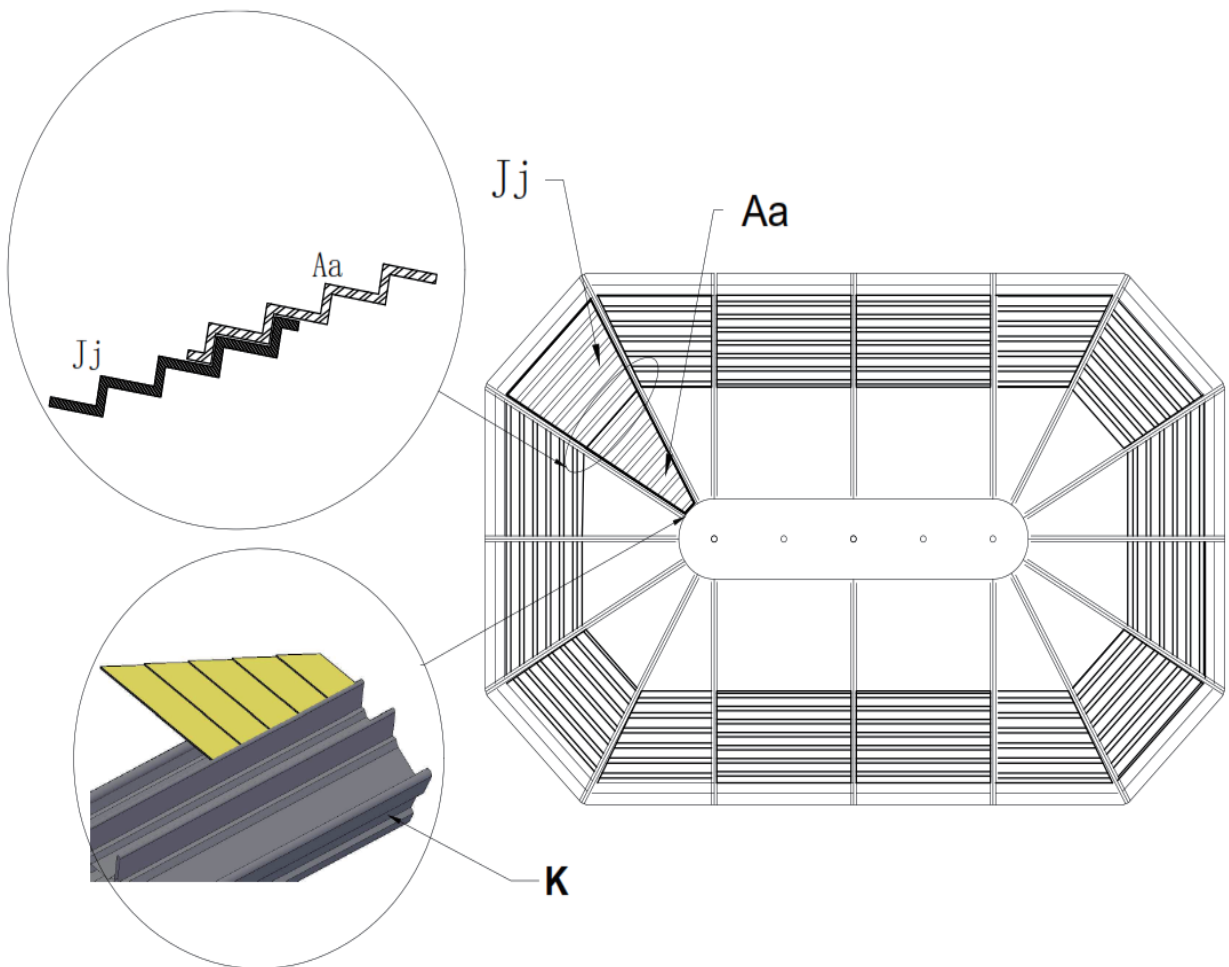

Étape 11:

1. Une fois l'installation du panneau de toit (Aa) terminée, sécurisez-le sur le chevron d'un côté de votre choix à l'aide du couvercle de chevron (O) et des vis (Oo1), puis placez un autre panneau de toit et répétez cette étape.

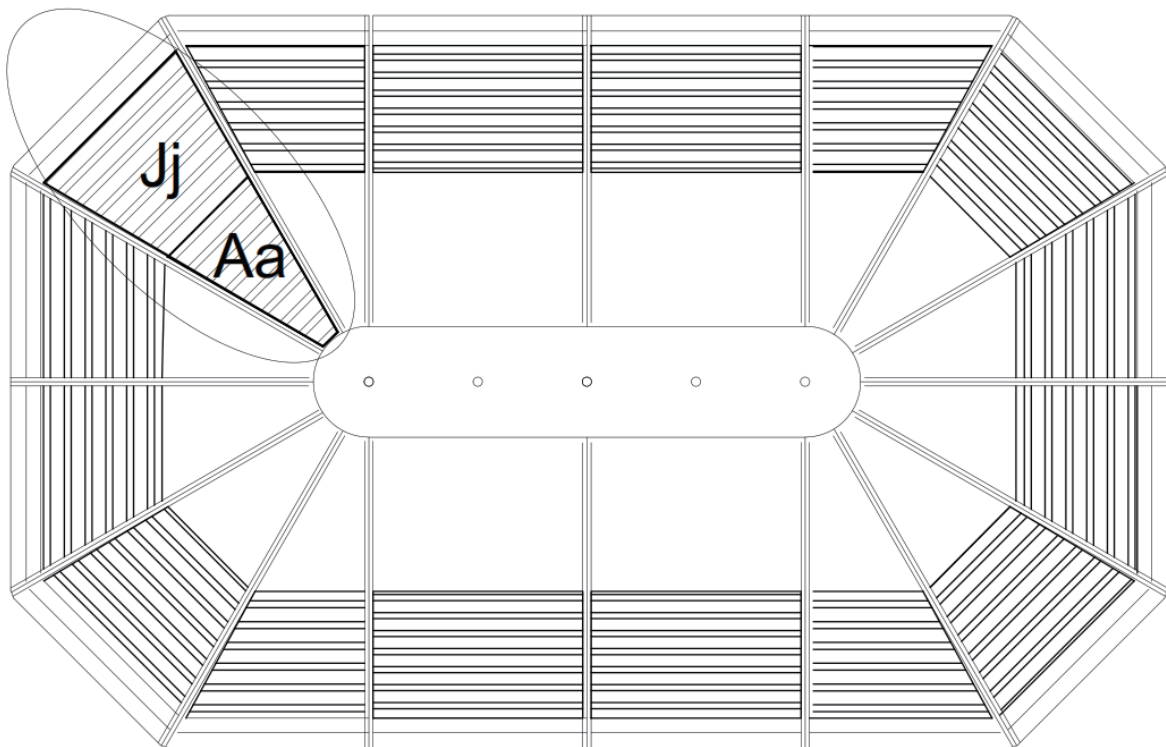
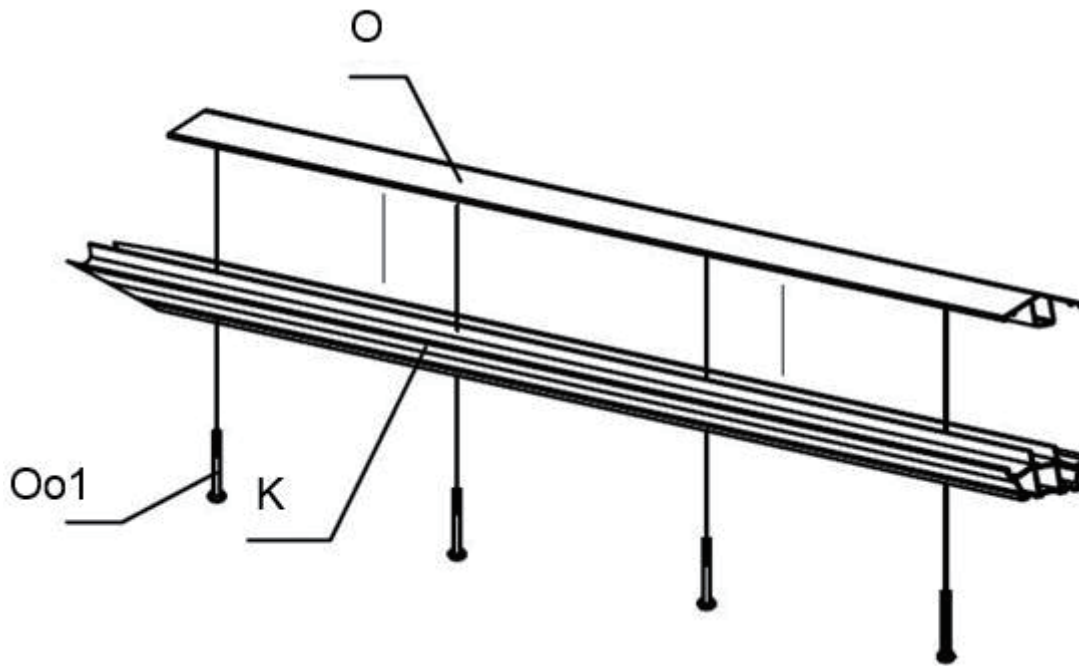

Étape 12:

1. Installez les panneaux de toit supérieurs (Aa, Ll, Qq, Y) en les glissant sur le dessus des chevrons de toit (K, L) à l'exception d'un panneau de toit (Qq), sécurisez-les à l'aide des couvertures de chevrons (0 et 01).

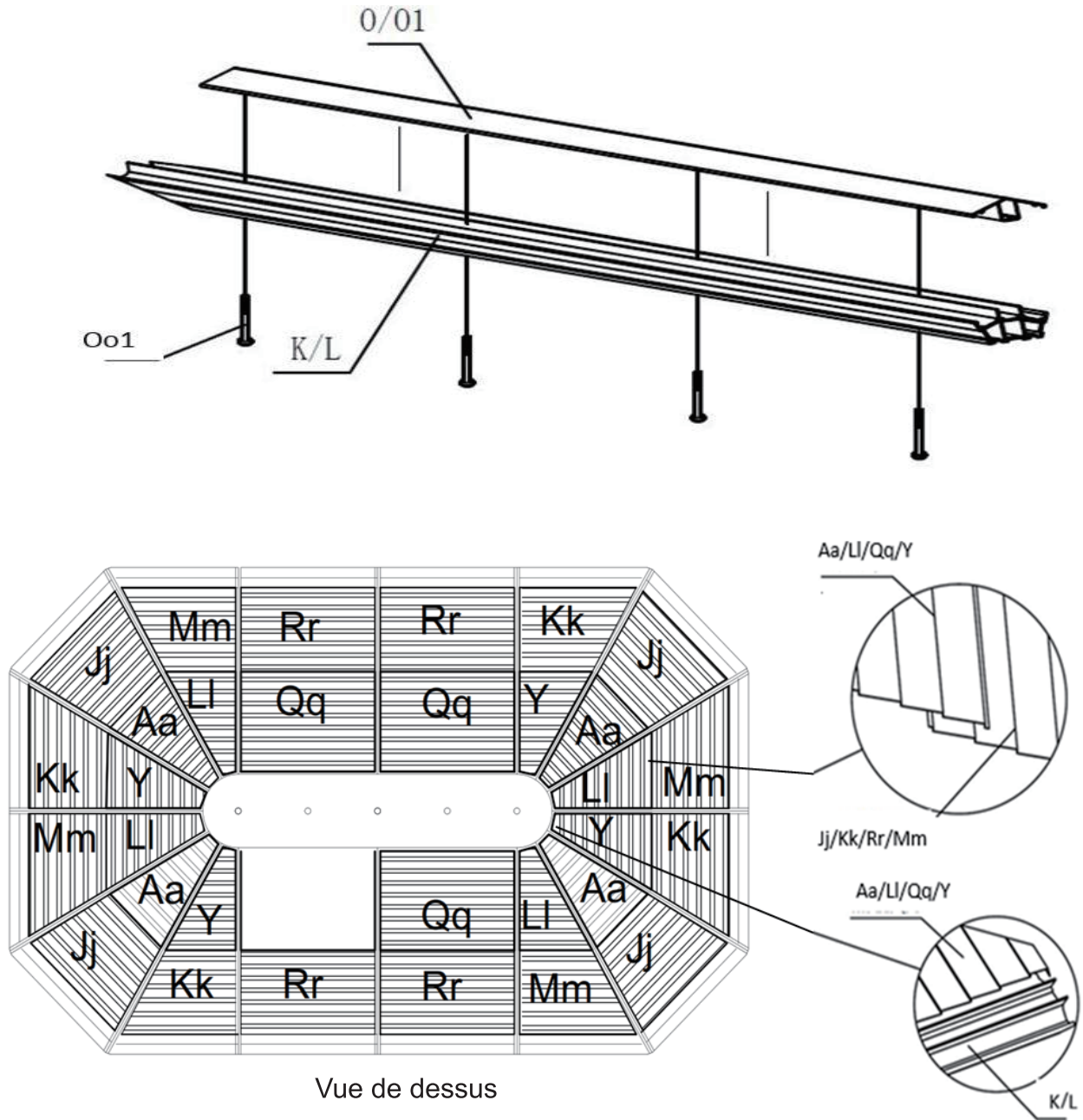

Étape 13:

1. Utilisez l'écrou (Hh) et la rondelle (Gg) pour attacher le capuchon supérieur (M) sur le connecteur central (N).

Remarque: Cette pièce est lourde et doit être manipulée avec précaution.

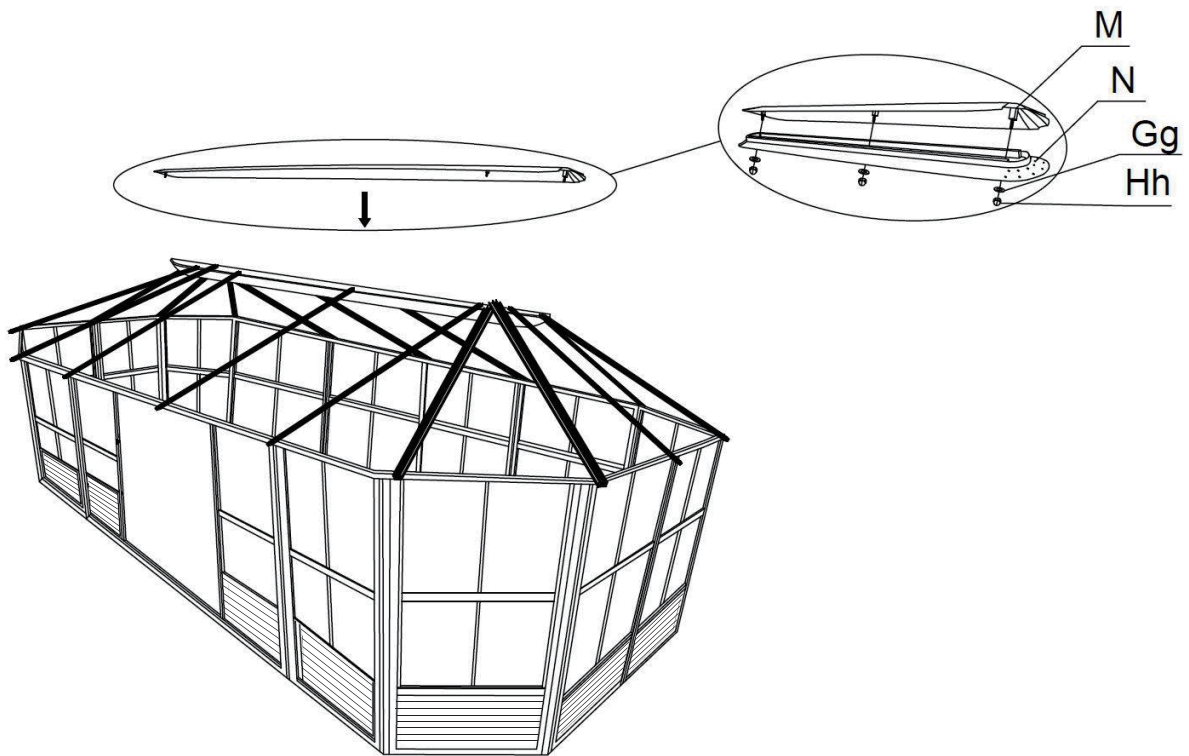

Étape 14:

1. Installez le dernier panneau de toit supérieur (Qq).

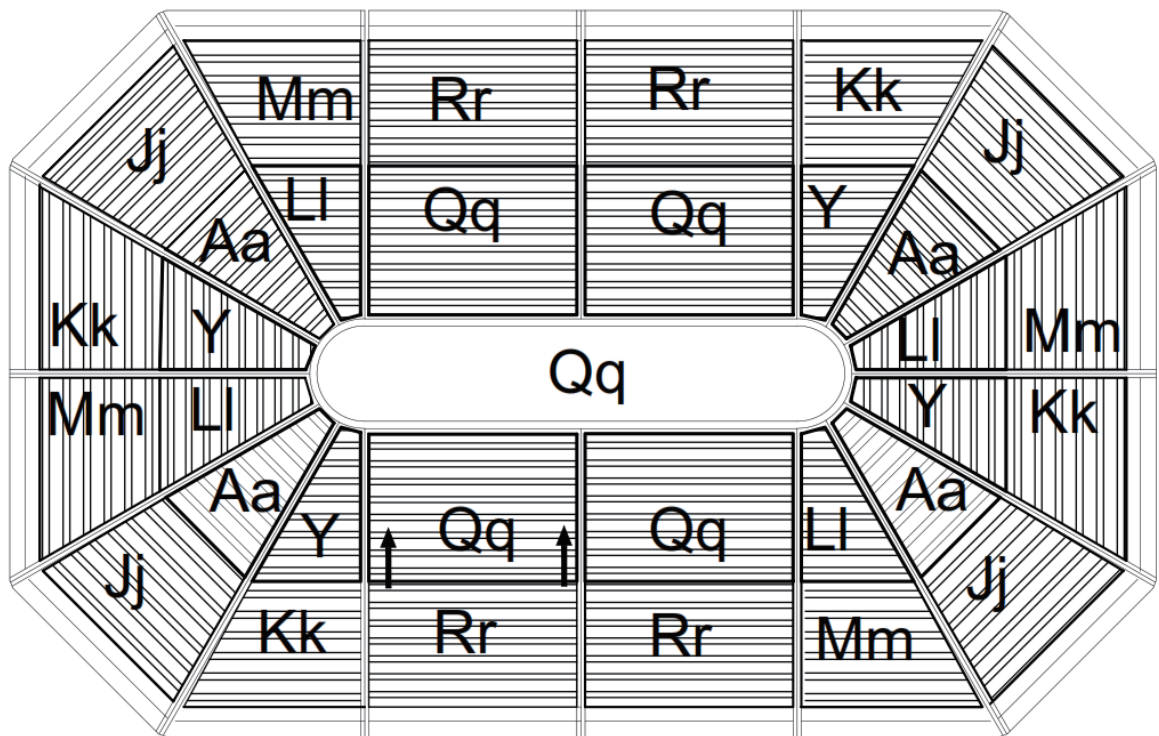

Vue de dessus

Étape 15:

1. Une fois le dernier panneau de toit installé, attachez la couverture de chevron (O1) à chevron (L) avec le boulon (Oo1).

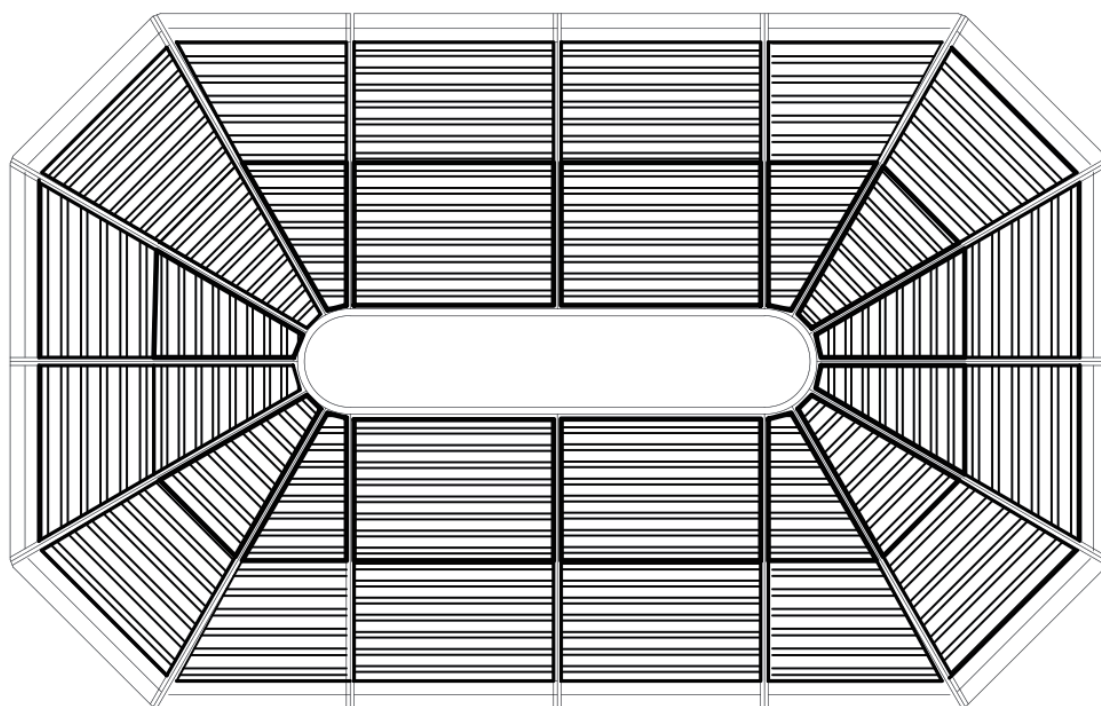
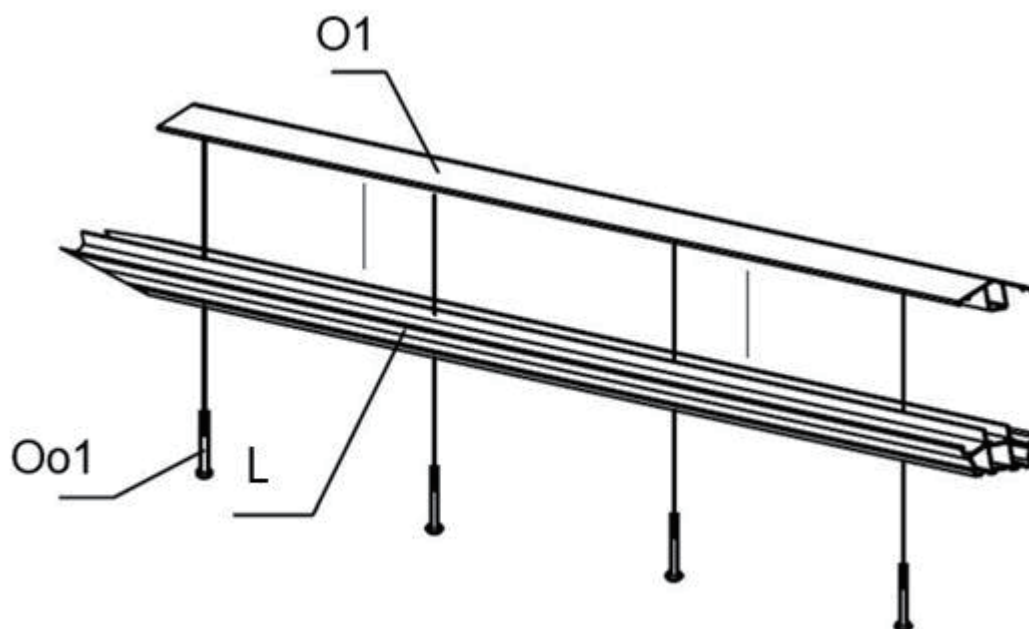

Vue de dessus

***Suggestions**

Les éléments mentionnés ci-dessous ne sont que des suggestions afin de permettre l' drainage, elles varieront en fonction de votre revêtement de sol - matériel, platitude epente.

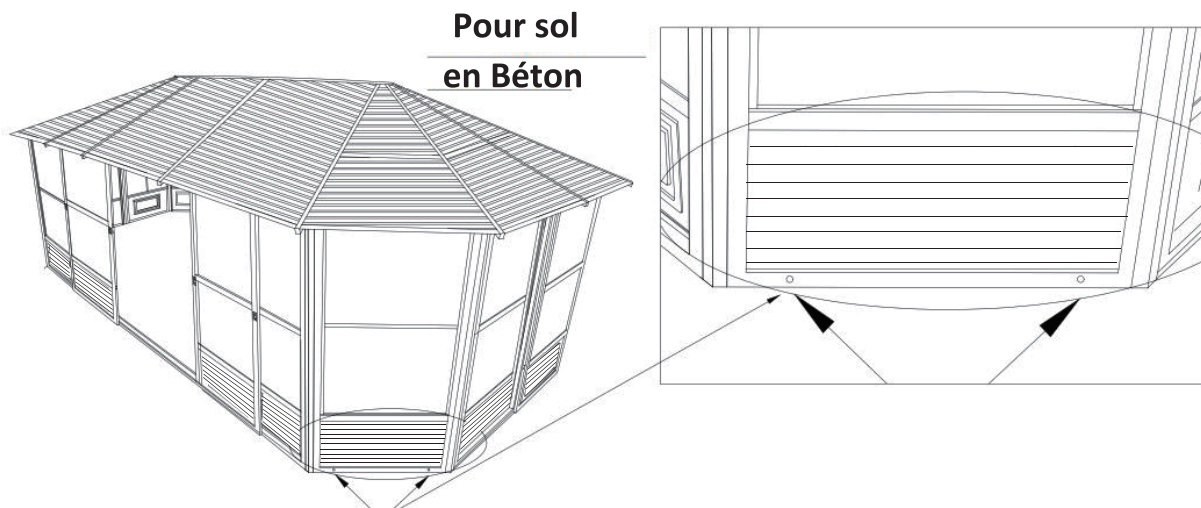

Sur la face extérieure, il est suggéré de percer de trous à l'extrémité inférieure des panneaux pour permettre le drainage

Pour Deck en bois

Forez les ponts où se trouvent les trous de drainage pour permettre de l'eau passer à travers.

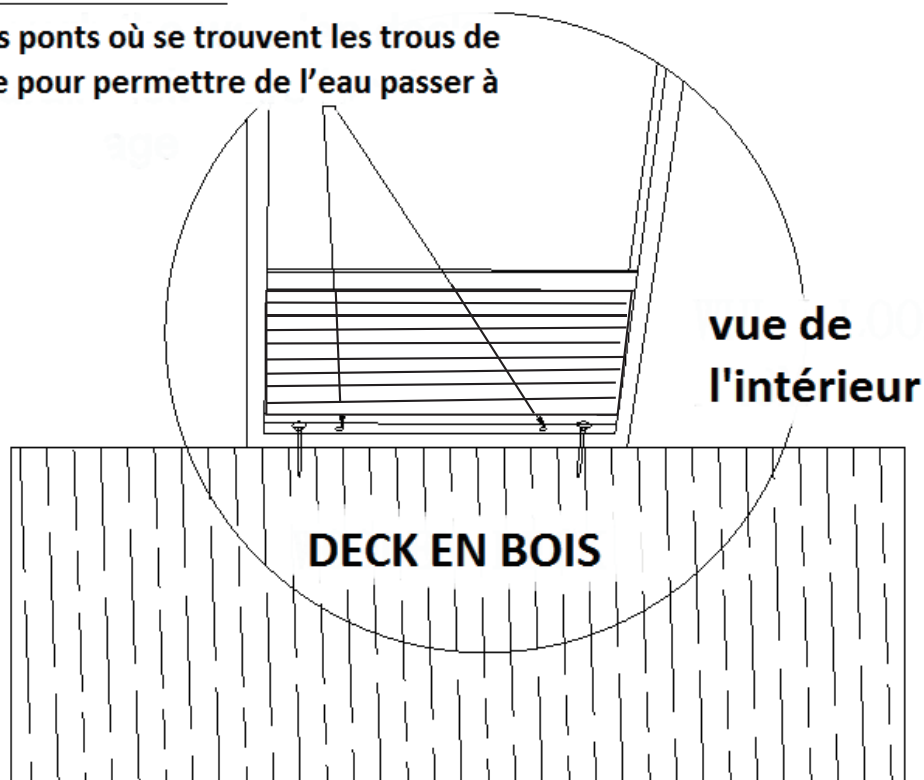

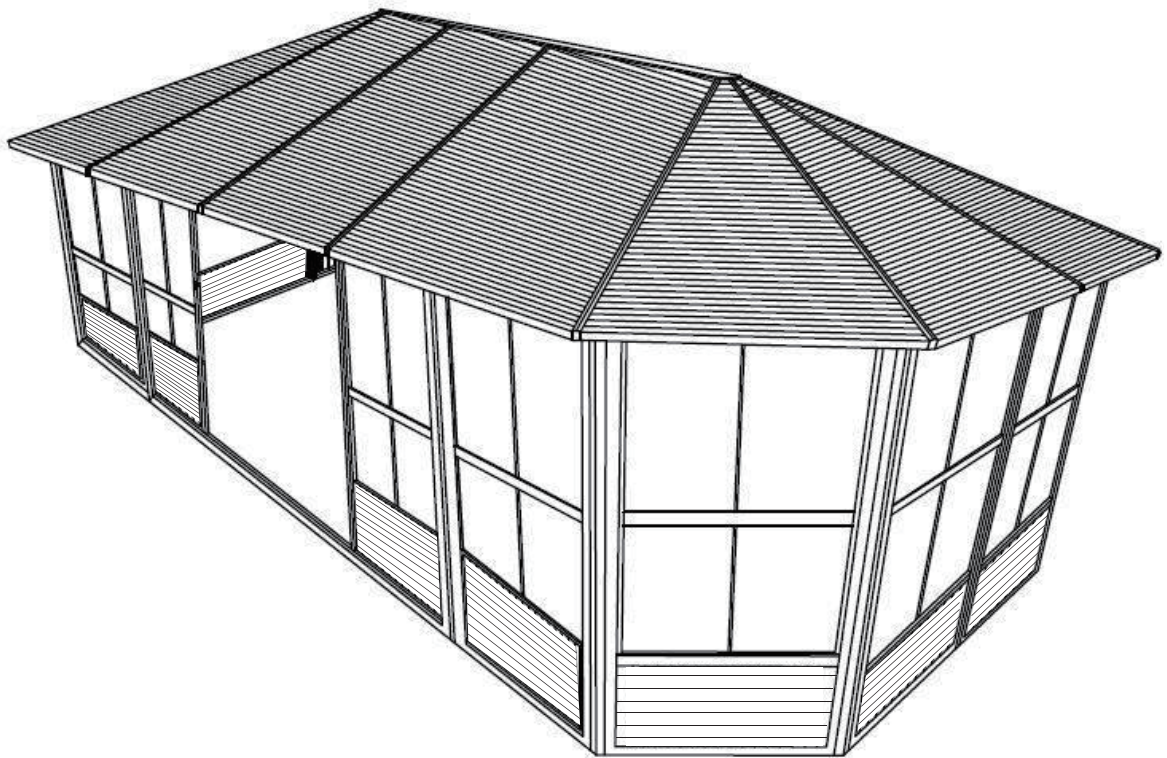
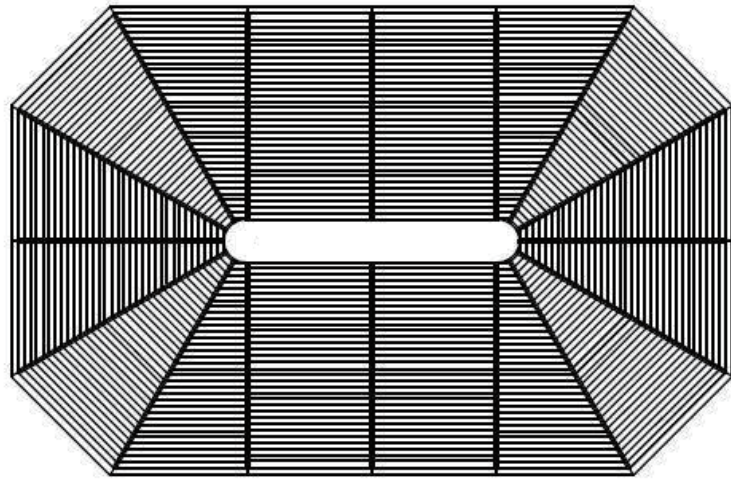

GARANTIE

Inspectez soigneusement le contenu de l'emballage afin de vérifier si certaines composantes sont manquantes ou endommagées. Advenant que certaines pièces soient manquantes ou endommagées, **ne retournez pas le produit à l'endroit où vous l'avez acheté**; contactez plutôt le département d'expérience client de Gazebo Penguin

Montréal : (514) 276-3485

Ailleurs au Canada et États-Unis : 1-800-737-7174

info@gazebopenguin.com

Ce produit a été conçu et fabriqué afin de répondre aux normes les plus exigeantes en matière de qualité et de durabilité.

Sous réserve de la section « limitations et exclusions à la garantie » ci-dessous, il est garanti contre les défauts matériels ou de fabrication:

- 1 AN SUR LES DÉFAUTS MANUFACTURIERS

Advenant que le produit soit endommagé ou que la période de garantie soit expirée, veuillez contacter le département d'expérience client de Gazebo Penguin afin d'obtenir une liste complète des pièces de remplacement et des prix.

LIMITATIONS ET EXCLUSIONS À LA GARANTIE

- 1. Dommages non couverts:** Cette garantie ne couvre pas les dommages causés par le vent, la chute d'objets, le feu, les animaux, la végétation, le vandalisme, les conditions climatiques extrêmes, ni les effondrements dus à l'accumulation de neige et de glace.
- 2. Entretien du toit:** Le toit doit rester libre de toute accumulation de neige ou de glace. Ces accumulations doivent être retirées en sections de cinq pieds (5) à la fois, de droite à gauche. Les dommages causés par un défaut d'entretien du toit ne sont pas couverts par la garantie.
- 3. Retrait de neige et de glace:** Le retrait de neige ou de glace depuis l'intérieur du produit est interdit, car il peut causer des dommages au produit.
- 4. Positionnement:** Il est déconseillé de placer le produit à proximité d'immeubles ou d'arbres, car la neige ou la glace peut glisser et s'accumuler sur le toit, provoquant un poids excessif.
- 5. Installation:** La garantie est valide uniquement si le produit est installé conformément aux instructions fournies par Gazebo Penguin. Une installation incorrecte, notamment un ancrage inadéquat, annule la garantie.
- 6. Infiltration d'eau:** Des infiltrations d'eau peuvent survenir en cas de fortes pluies. Consultez le manuel d'instructions pour les positions des fenêtres et les informations sur l'évacuation de l'eau.
- 7. Clause de remplacement:** Nous nous réservons le droit de réparer ou remplacer tout produit ou pièce défectueuse, à notre seule discrétion.
- 8. Modifications:** Toute modification ou ajout au produit annule la garantie.



MANUEL D'INSTRUCTIONS

INSTRUCTION MANUAL

Florence Solarium 12 Pl. X 18 Pl. - Toit d'Acier
Florence Solarium 12 FT. X 18 FT. - Metal Roof

sku: 41218MR-GP-12		
sku: 41218MR-GP-32		
sku: 41218MR-GP-42		

DO NOT DESTROY THE BOXES UNTIL COMPLETELY ASSEMBLED

FOR FUTURE REFERENCE,

TAKE PICTURES OF ALL SIX SIDES OF EACH OF THE BOXES UPON RECEIPT.

PLEASE VERIFY THE CONTENT OF EACH BOX AGAINST THE LIST OF PARTS

12ft x 18ft / 3.66m x 5.49m Meters Solarium

Instruction Manual

IMPORTANT: RETAIN FOR FUTURE REFERENCE, READ CAREFULLY

Consult with your local governing authority / local municipal codes regarding installation of temporary structures before purchase or assembly. Some jurisdictions may require permits for, or otherwise regulate, installation and use.

For assistance with assembly, installation, parts, or customer service, contact Gazebo Penguin Customer Service Department at the numbers listed below (English & French, Mon-Fri 8:00 AM to 4:00 PM EST):

Montreal: (514) 276-3485

Elsewhere in Canada and the US: 1-800-737-7174

WARNING:

- For outdoor use.
- Snow should be regularly cleared from the roof and not allowed to accumulate.
- Retain your **proof of purchase** for warranty purposes. Also keep the **original boxes** until the installation is complete and correct.
- The unit may take more than 4 hours and 3 people are required for this assembly.



PRIOR TO ASSEMBLY:

- Please don't destroy boxes until completely assembled.
- The foundation must be level, flat, and solid, such as concrete or asphalt.
- Keep away from overhead utility lines, tree branches, and other structures.
- Check for underground pipes or wires if digging or drilling is required.
- Do not install near roof lines or other structures that could shed snow, ice, or excessive rain run-off onto the roof top.
- Assemble the structure as close to its final location as possible.
- It is recommended to wear safety gloves, safety glasses, and hard hats for installation.
- Do not hang from, climb on, or stand on the structure or roof.
- Before assembly, read instructions and check that all parts are present in the boxes. If any parts are missing, refer to warranty information.
- A 6ft (1.8m) stepladder, Phillips screwdriver, tape measure, level, mallet, and a tarp to place parts on will be required for assembly (not included).
- Remove top protective film from roof panels prior to assembly; DO NOT remove bottom protective film until ready to insert roof panels, so as to identify which side is on top.

ANCHORING INSTRUCTIONS:

- Proper anchoring of the frame to the base and the wall is required for safety.
- Any structure not anchored securely has the potential to fly away during high wind causing damage and safety hazard.
- How the item is anchored, and the hardware and tools required, will vary based upon the set up location and are not provided.
- Please check with your local hardware store if for the appropriate anchors for your surface.
- Do not anchor to pavers / pavement slabs because they are not a solid foundation.
- Periodically check the anchors to ensure they remain secure

CARE AND MAINTENANCE:

- In case of a defective or damaged part, or for any other questions concerning the product, please contact the manufacturer directly.
- Please have the parts list and part numbers on hand when ordering or requesting replacement parts.









ROOF PANELS:

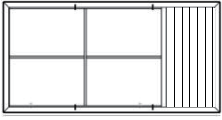
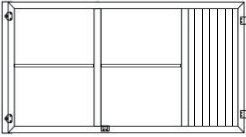

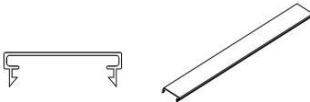
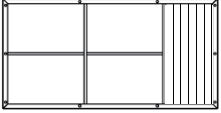





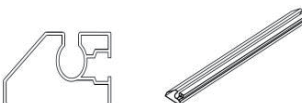
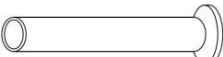
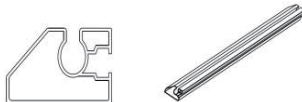

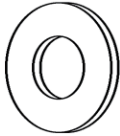
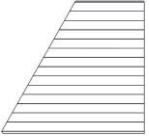
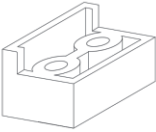
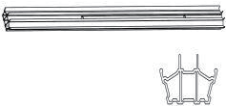
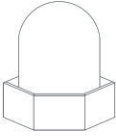
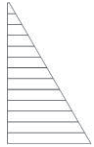
- Gently clean with an environmentally-friendly soap solution and water using a sponge or washcloth.
- Do not use abrasive materials, wire brushes, chemicals, harsh cleaners, or bleach.
- Rinse using a garden hose and air dry. If removed, ensure thoroughly dry prior to storage.
- Do not use pressure washer.

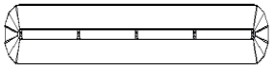

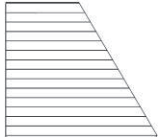

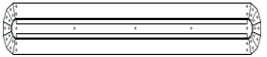
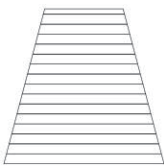
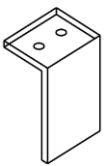





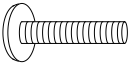
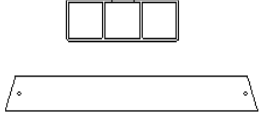

STRUCTURE:

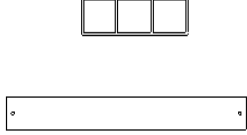
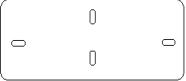

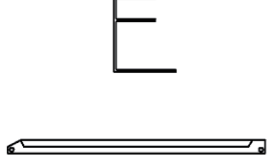

- Gently clean with an environmentally-friendly soap solution and water using a sponge or washcloth.
- Do not use abrasive materials, wire brushes, chemicals, harsh cleaners, or bleach.
- Rinse using a garden hose and air dry.
- Do not use pressure washer.
- If there are nicks, chips, and/or scratches see the part # of the paint in the parts list to obtain a matching touch-up paint.

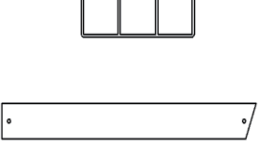
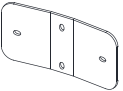



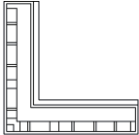

12 x 18 Solarium

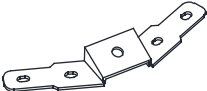
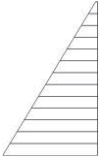
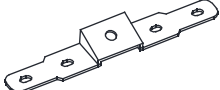
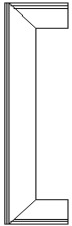
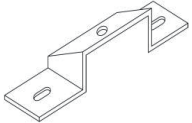
DESCRIPTION	PACKED IN BOX	QTY	DRAWING	DESCRIPTION	PACKED IN BOX	QTY	DRAWING
23-086 REGULAR FRAME A	3	4		23-089 SLIDING DOOR WITH RECEIVER CHANNEL D	3	1	
	4	8					
17-054 ROOF PANEL Aa	1	4		08-133 CONNECTING PIECE 78.9" E	5	14	
23-087 FRAME NEXT TO DOORS (extra holes) B	3	2		23-215 Allen wrench QQ	5	1	
25-114 SCREW M6*16 Bb	5	140		08-162 TOP DOOR RAIL LEFT 81.9" F	5	1	
23-088 SLIDING DOOR - REGULAR C	3	1		08-221 TOP DOOR RAIL RIGHT 81.9" F1	5	1	
25-115 SCREW M6X73 Cc	5	12		08-163 BOTTOM DOOR RAIL LEFT 81.9" G	5	1	
25-117 CAPNUT M5X60 Cc-2	5	12		08-220 BOTTOM DOOR RAIL RIGHT 81.9" G1	5	1	

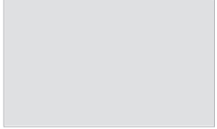
DESCRIPTION	PACKED IN BOX	QTY	DRAWING	DESCRIPTION	PACKED IN BOX	QTY	DRAWING
08-187 WASHER Gg	5	73		17-061 ROOF PANEL Kk	2	4	
08-138 DOOR STOPPER H	5	2		17-044 RAFTER 78.9" L	5	8	
08-189 ACORN NUT Hh	5	5		17-057 ROOF PANEL Li	2	4	
08-139 CONNECTING PIECE 78.9" I	5	8		08-164 TOP CAP M	5	1	
23-223 Allen wrench RR	5	1		17-058 ROOF PANEL Mm	2	4	
08-140 CONNECTING PIECE 78.9" J	5	8		08-166 CENTRAL HUB N	5	1	
17-055 ROOF PANEL Jj	1	4		08-134 UPPER DOOR RAIL END CAP Nn	5	2	
17-043 RAFTER 89.9" K	5	8		17-049 COVER FOR RAFTER 88.9" O	5	8	
17-050 COVER FOR RAFTER 78.5" O1	5	8		17-046 FINISHING BAR 45.3" S	5	4	

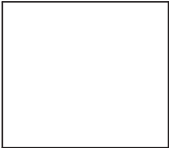
DESCRIPTION	PACKED IN BOX	QTY	DRAWING	DESCRIPTION	PACKED IN BOX	QTY	DRAWING
08-135 SCREW Oo	5	4		17-068 FINISHING BAR 42.6" Ss	5	4	
25-116 SCREW M6 X 36 Oo1	5	64		17-048 SOLIDIFYING BAR 20.8" T	5	4	
17-051 GAP COVER BAR 39.7" P	5	12		17-069 SOLIDIFYING BAR 39.4" Tt	5	4	
18-067 SOLIDIFYING BAR BRACKET Pp	5	8		17-045 FINISHING BAR 45.2" U	5	4	
17-075 ROOF PANEL Qq	1	4		17-071 FINISHING BAR 45.2" U1	5	4	
17-053 END CAP R	5	8		17-047 SOLIDIFYING BAR 20.8" V	5	4	
17-076 ROOF PANEL Rr	1	4		17-070 SOLIDIFYING BAR 20.8" V1	5	4	
23-004 SOLIDIFYING BAR BRACKET Pp-1	5	8		23-005 END CAP R1	5	8	

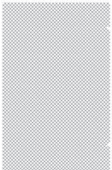
DESCRIPTION	PACKED IN BOX	QTY	DRAWING	DESCRIPTION	PACKED IN BOX	QTY	DRAWING
11-599 CORNER KEY Vv (Installed in Yy)	3	4		08-156 SCREW M5 X 20 Z	5	96	
25-118 SCREW M5 X 15 Ww	5	12		11-598 HORIZONTAL BAR FOR DOOR FRAME 81.1" Zz	3	2	
23-003 GAP COVER BAR 40.3" P-1	5	4		15-124 STEEL ANGLE Z1	5	8	
17-060 ROOF PANEL Y	2	4		15-125 STEEL ANGLE Z2	5	7	
11-597 VERTICAL BAR DOOR FRAME 78.7" Yy	3	2		19-102 STEEL ANGLE Z3	5	1	

AVAILABLE REPLACEMENT PARTS			
DESCRIPTION	DRAWING		DRAWING
08-219 PVC WINDOW (in frame)			23-090 BOTTOM STEEL PANEL (for wall panels)
10-493 PVC WINDOW (replacement material only)			23-091 BOTTOM STEEL PANEL (for double doors)
85-417-P ROUND SPLINE FOR PVC WINDOW			15-097 DOOR WHEEL ASSEMBLY
15-123 PIN FOR PVC WINDOW			11-736 RECEIVER CHANNEL FOR DOUBLE DOOR
13-054 PC WINDOW (for double door)			10-458 REPLACEMENT WEATHERSTRIP
12-046 MOSQUITO SCREEN (in frame)			15-124 STEEL ANGLE Z1
85-014 REPLACEMENT SCREENING (no frame)			15-125 STEEL ANGLE Z2
85-417-S ROUND SPLINE FOR SCREENING			19-102 STEEL ANGLE Z3
DESCRIPTION	COLOUR	PART #	
SPRAY PAINT	SAND	11-699	
PAINT PEN		18-245	

NOTE: The dimensions are approximate.

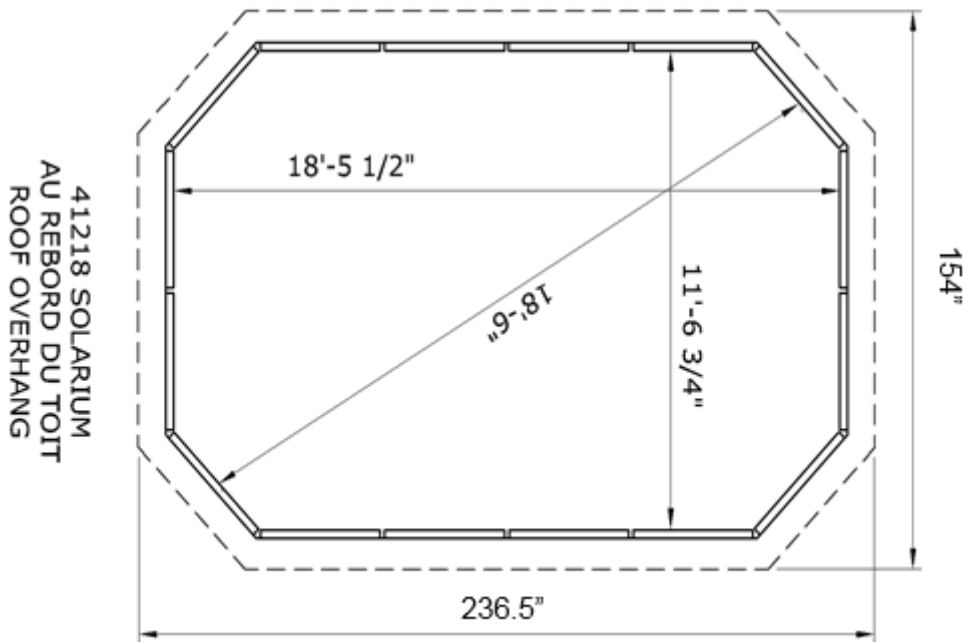
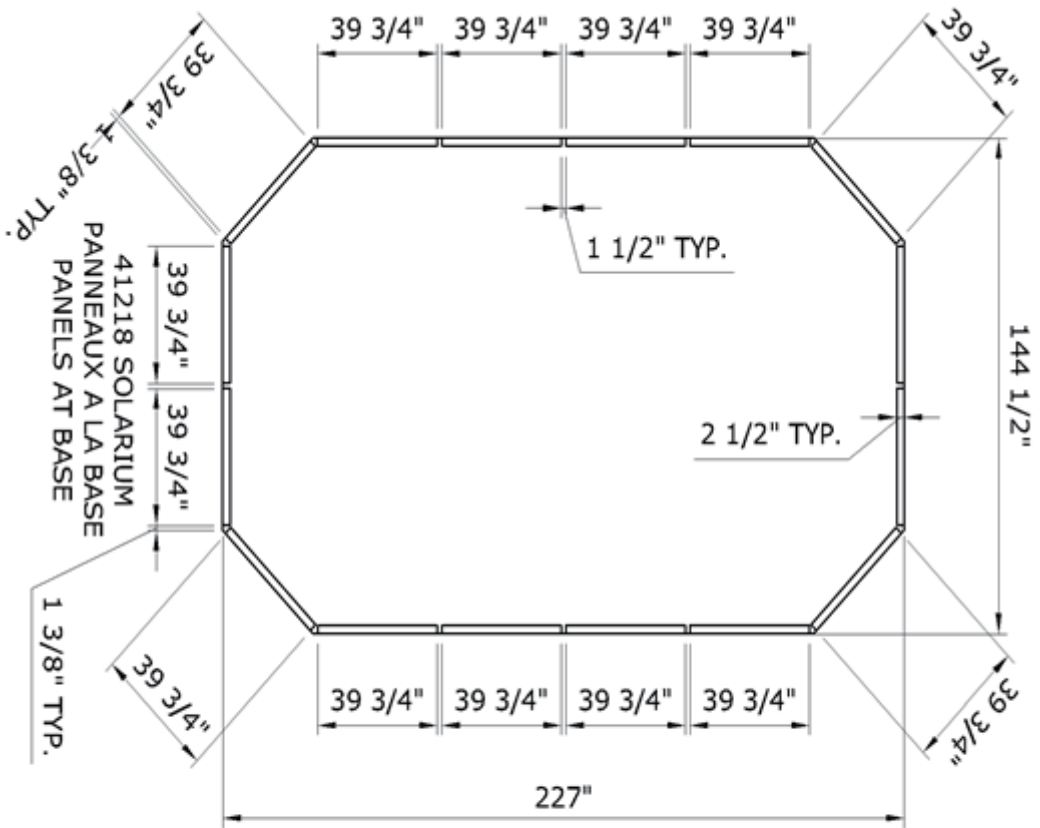

Before you assemble the Solarium

- Please don't destroy boxes until completely assembled.
- For future reference, take pictures of all six sides of each of the boxes upon receipt.
- Please verify the content of each box against the list of parts.

Tools needed:

- Step Ladder 6' – 8'
- #2 Phillips Screwdriver, Robertson #2 (not supplied)
- Rubber Mallet
- Various Files
- Drill Machine
- Drill bit 1/8" for Pilot holes

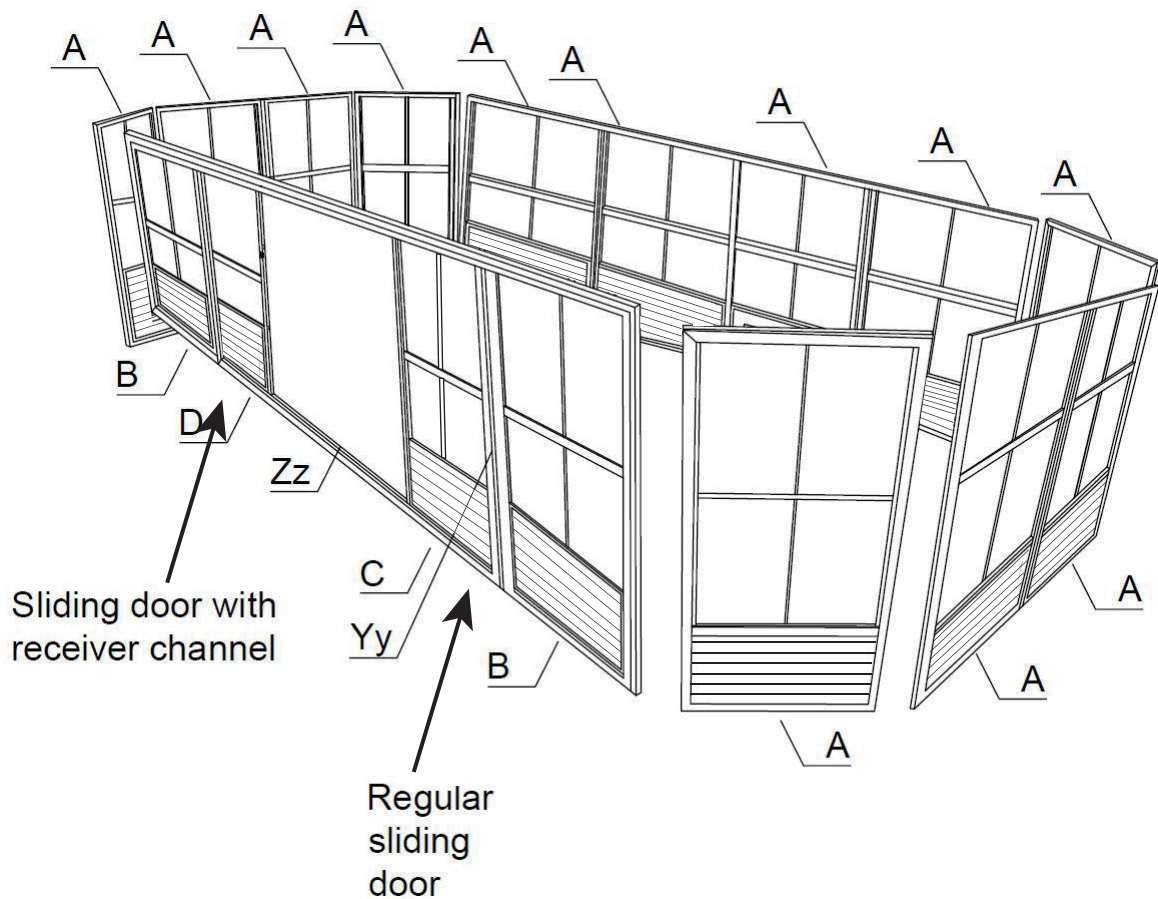

Based on the location, decide where you would like to position the two (2) doors panels

Step 1:

Before starting to assemble, please decide where you would like to position the door panels.

1. Stand up two Regular Frames (A) and affix the panels together at an angle by sliding two connecting Pieces (I, J) from top to bottom. All Frames should be placed such that screening face out of the unit.
2. To assemble door frame, firstly assemble 2 vertical bars (Yy) with 2 horizontal bars (Zz). Make sure the shape of the aluminum matches the other parts to be joined. With a rubber mallet get them closed at the corners. Make sure to not damage the aluminum parts. Make a small pilot hole if necessary, under 1/8" and use screws (Z) to secure 4 corners manually, screwing all screws into frame 4 holes.
3. After assembling door frame, attach to frames (B) on either side, by sliding connecting piece (E) between the frame and the door frame.
4. When assembling angled panels (A, B), you should put the two panels at 135-degree angle then use the angled connecting pieces (I) and (J) to affix the panels together.
5. Door frame step down is on the inside of the unit.

Note:

1. When sliding the part I, J and E into the frames shake the frames for it too slide. Do not apply excess force. Make sure the edges are clean from any extra paint if necessary, use a fine file.
2. Make sure the floor is level if not use Leveling Shims.

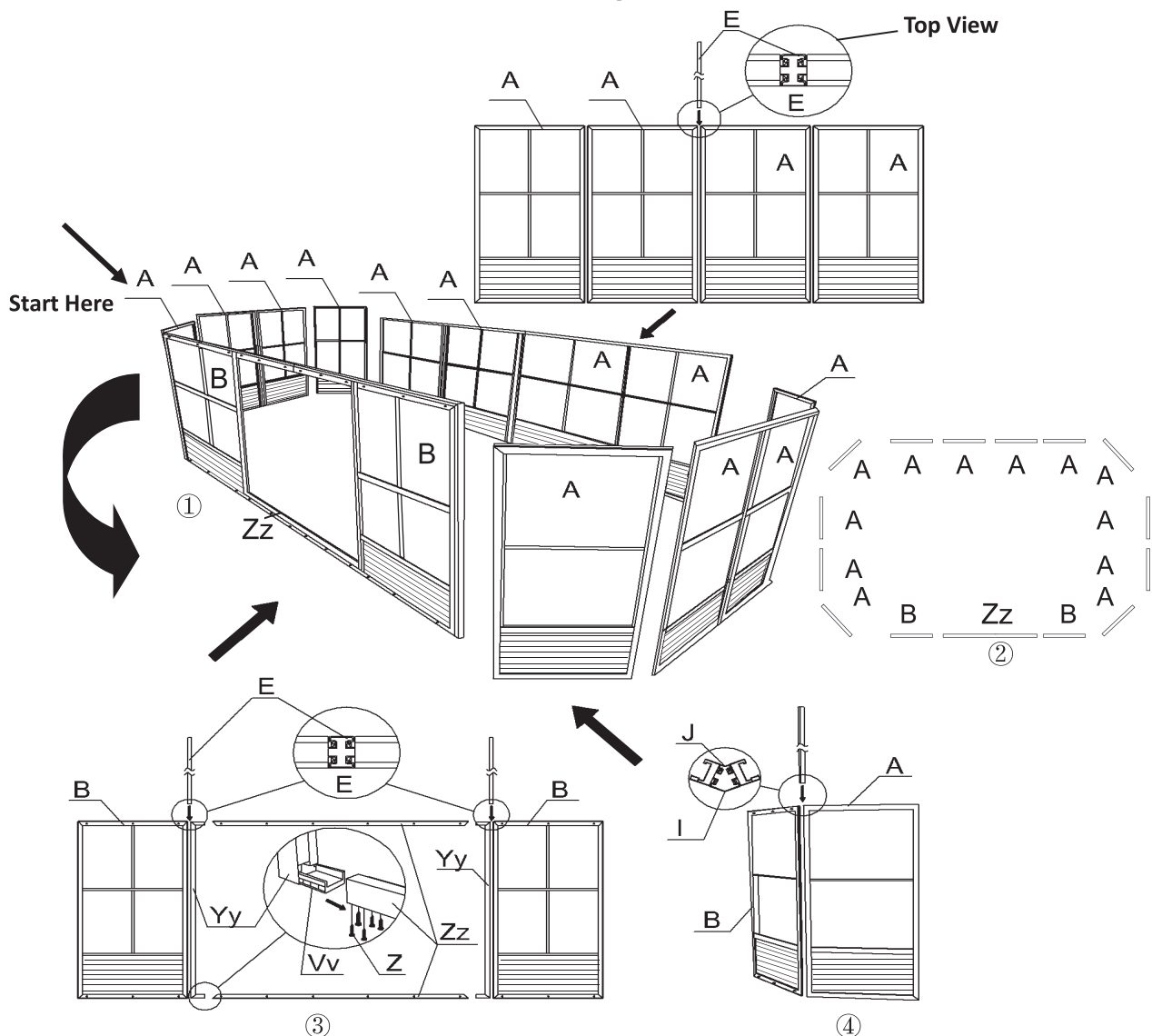

Step 2:

1. Affix gap Cover Bars (P) by sliding them on the top of the exterior groove of the Regular Frames (A, B, D).

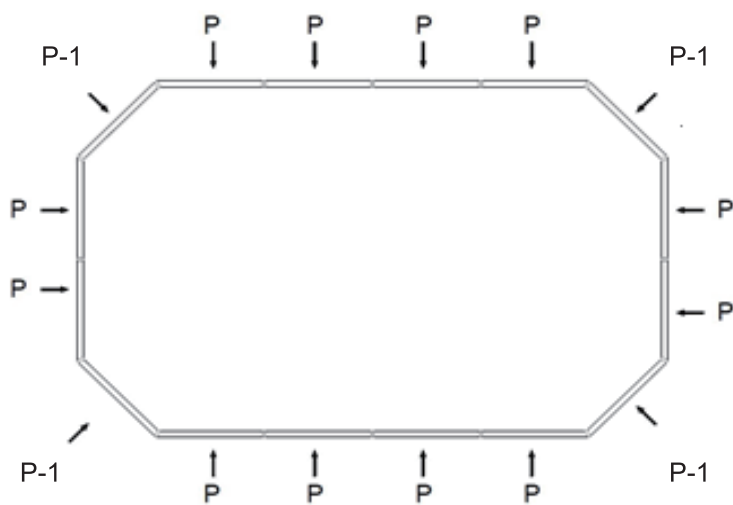
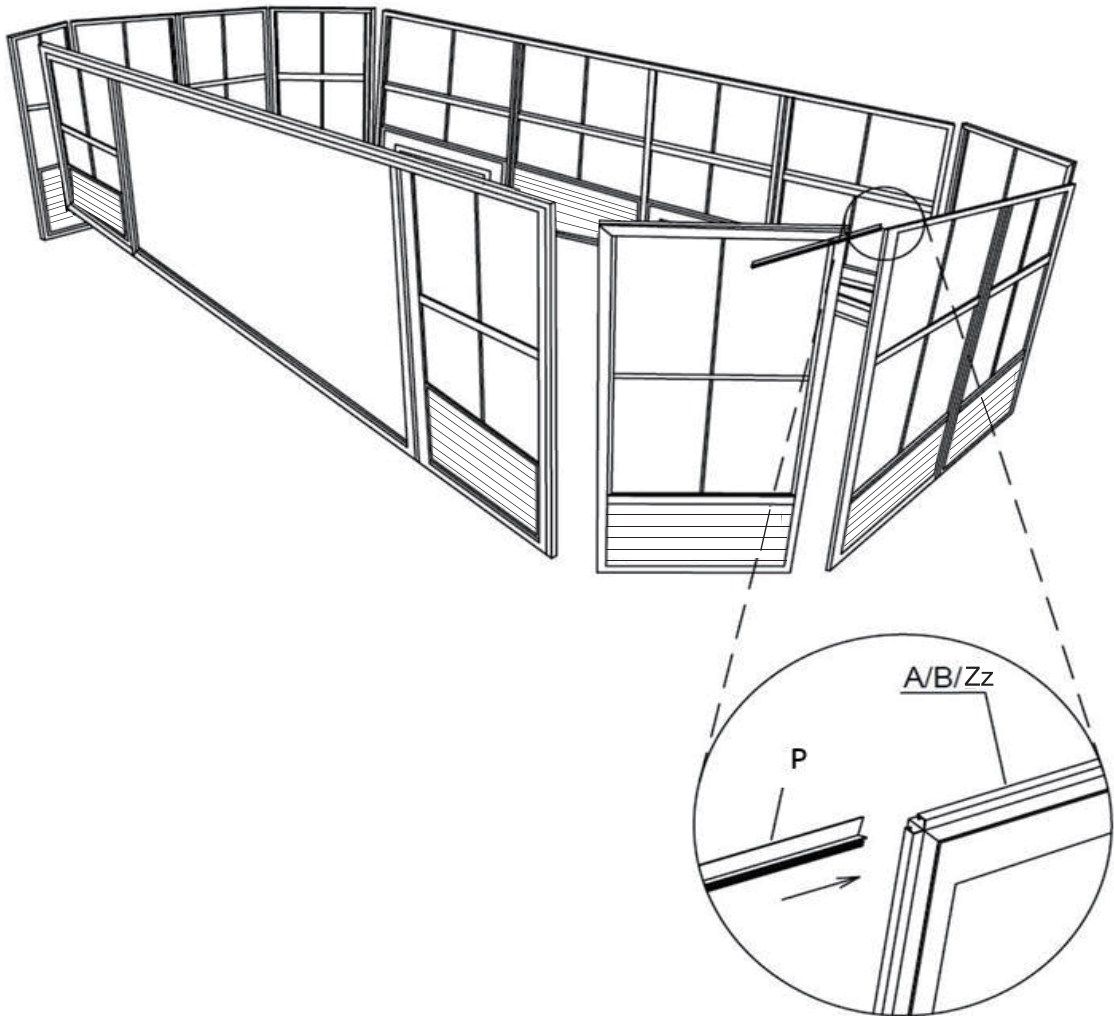

Step 3:

1. Slide Top Door Rail (F) into wheels of Sliding Door (C).
2. Slide Lower Door Rail (G) into the plastic guide of the Sliding Door (C).
3. Use Bolts (Bb) to affix the Plastic Stoppers (H) one on each end of Top Door Rail (F).
4. Using a Screw (Oo) affix the upper door rail End Caps (Nn) one on each end of Top Door Rail (F).
5. Similarly follow the above step to assemble the Sliding Door (D).

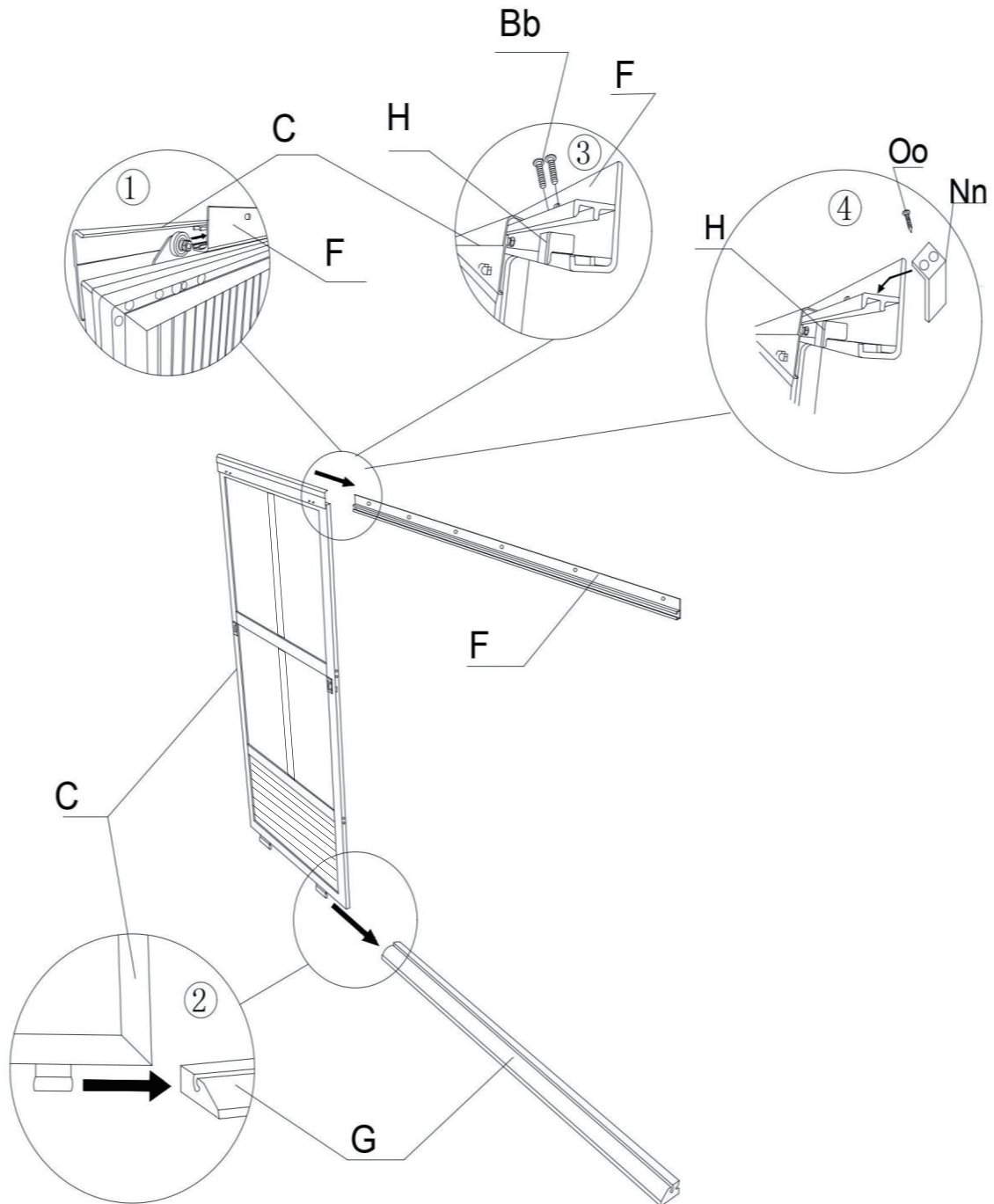

Step 4:

Please note the sliding door is suggested to be installed from the inside of the solarium.

1. Place a Bolt (Ww) through the Top of Sliding Door Frame (C) and Top Door Rail (F), and place a Female Bolt (Cc-2) from the other side. Once all are inserted, tighten them all securely.
2. Secure the Bottom Door Rail (G), using a Bolt (Cc).
3. Similarly follow the above step for Sliding Door (D) with Top Door Rail (F1) and Bottom Door Rail (G1).

Note: Adjust door rail high up, for easy sliding of door.

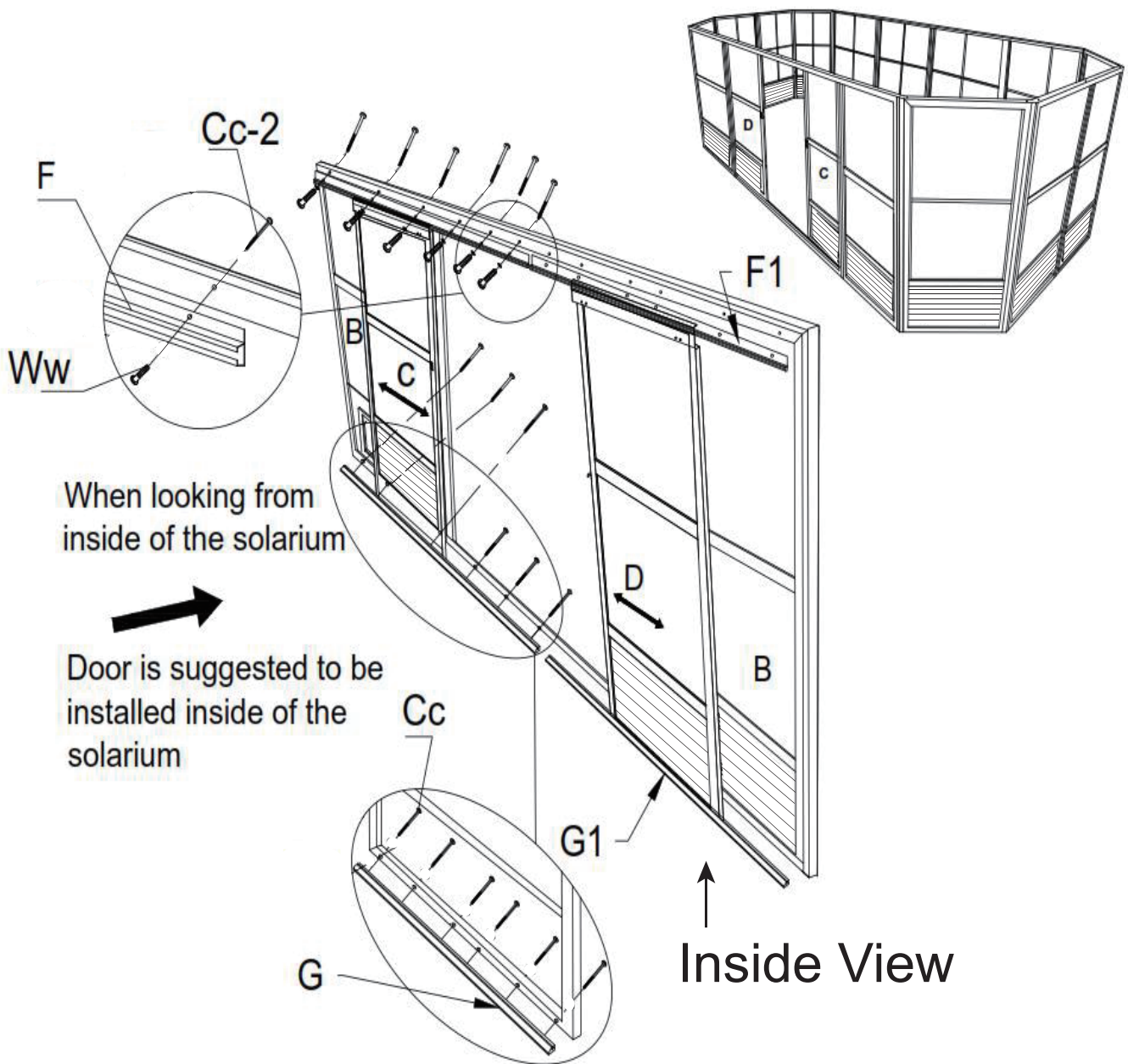

Step 5:

1. Assemble steel angle (Z2) to roof Rafters (L) using bolts (Bb). Assemble steel angle (Z3) to roof rafters (L) using bolts (Bb).
2. Attach roof rafters (L) to the Central Hub(N) using bolt (Bb).
3. Use screws (Z) to affix the Rafters (L) onto the top of panels going through the Metal Piece (Z2) attached to the Rafter (L).
4. Use Bolts (Bb) to affix Rafter (Z3) over the Horizontal Bar For Door Frame (Zz) at the top of Door opening as shown below.

Note:

1. Rafters must be affixed where panels connect to each other.
2. The Central Hub is a heavy part so it requires support while assembling.

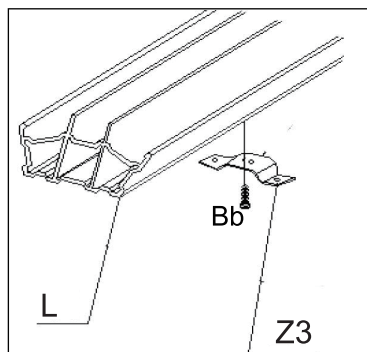
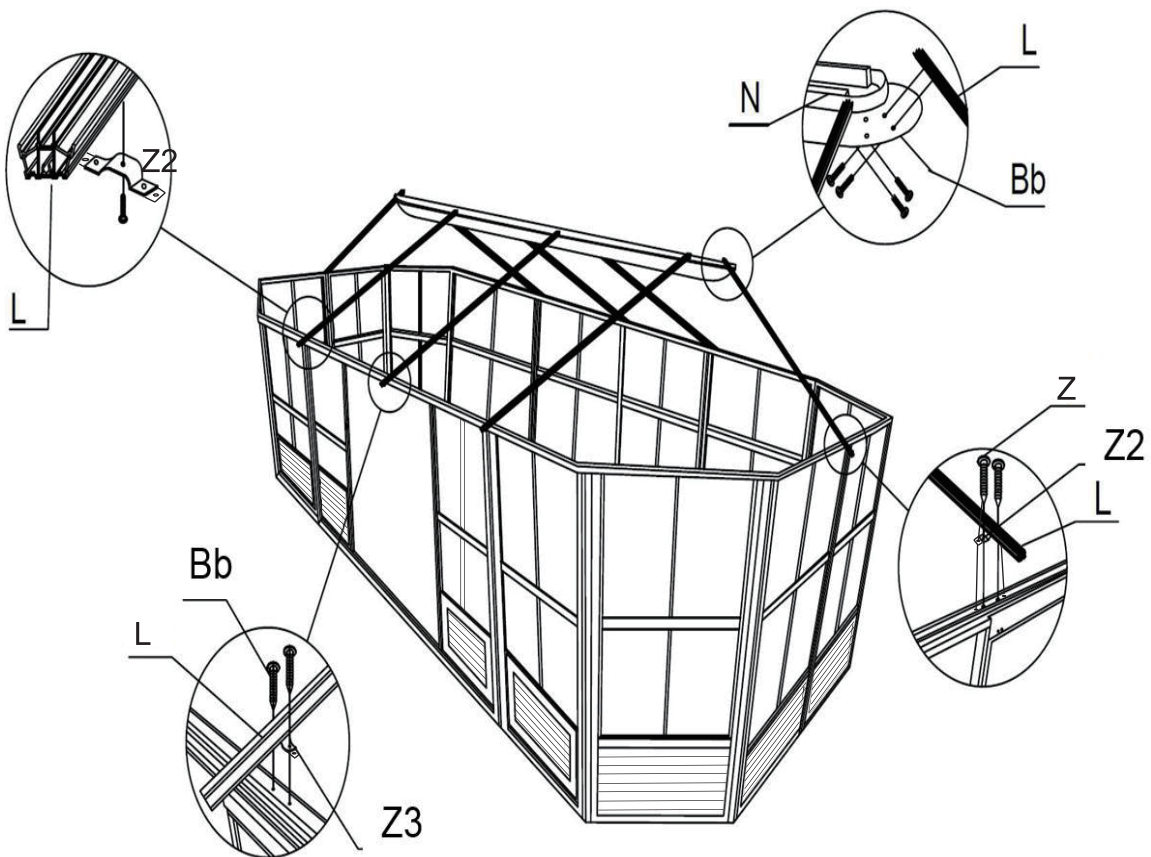

Step 6:

1. Follow the same procedure of Rafter (L) to assemble roof Rafters (K) onto the remaining panels.

Note:

1. Rafters must be affixed where panels connect to each other.
2. Affix the Rafter (K) such that, the extra hole on the bracket (Z1) are facing each other as shown below.
3. Do not tighten the bolts right away as you may have to adjust the angle when inserting the roof panels.

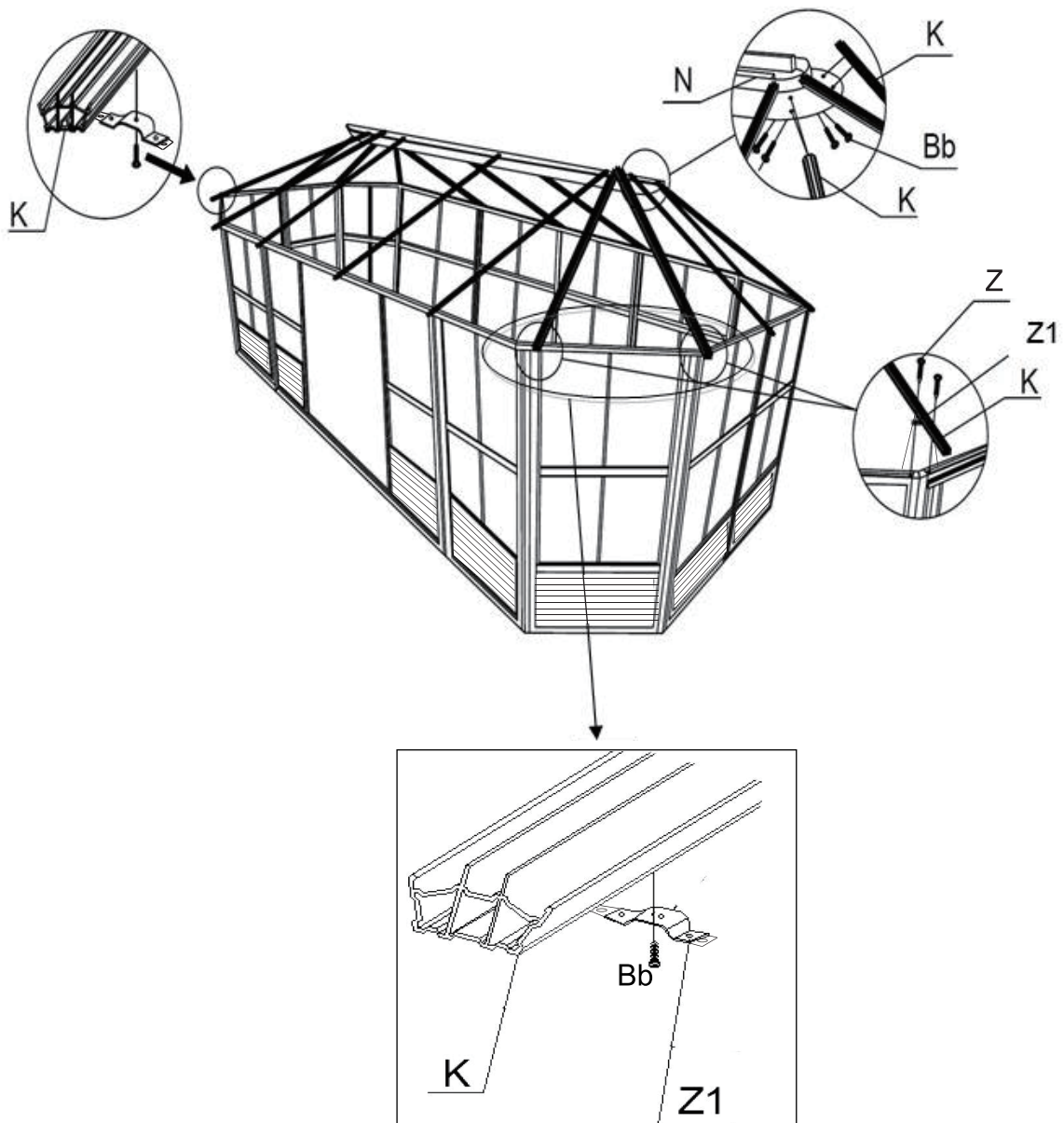

Step 7:

1. Now secure the sides of the roof with Finishing Bar (S, U, Ss and U1) with Bolts (Bb) and Brackets (R/R1).
2. Place roof Finishing Bars (S, U, Ss and U1) on the right of the Roof Finishing Bar (S, U and U1) and align the holes in each bar one on top of the other. Place End Caps (R) under the aligned holes and secure with Bolts (Bb).
3. Repeat process with all Finishing Bars as illustrated.
4. In order to finish the installation of the last Finishing Bar (S, Ss, U, U1) you have to unscrew the first screw (Bb) at your starting point and place an end cap (R) then re-install the screw (Bb).

Note: Make sure all screws/ bolts are tight, when finished assembling.

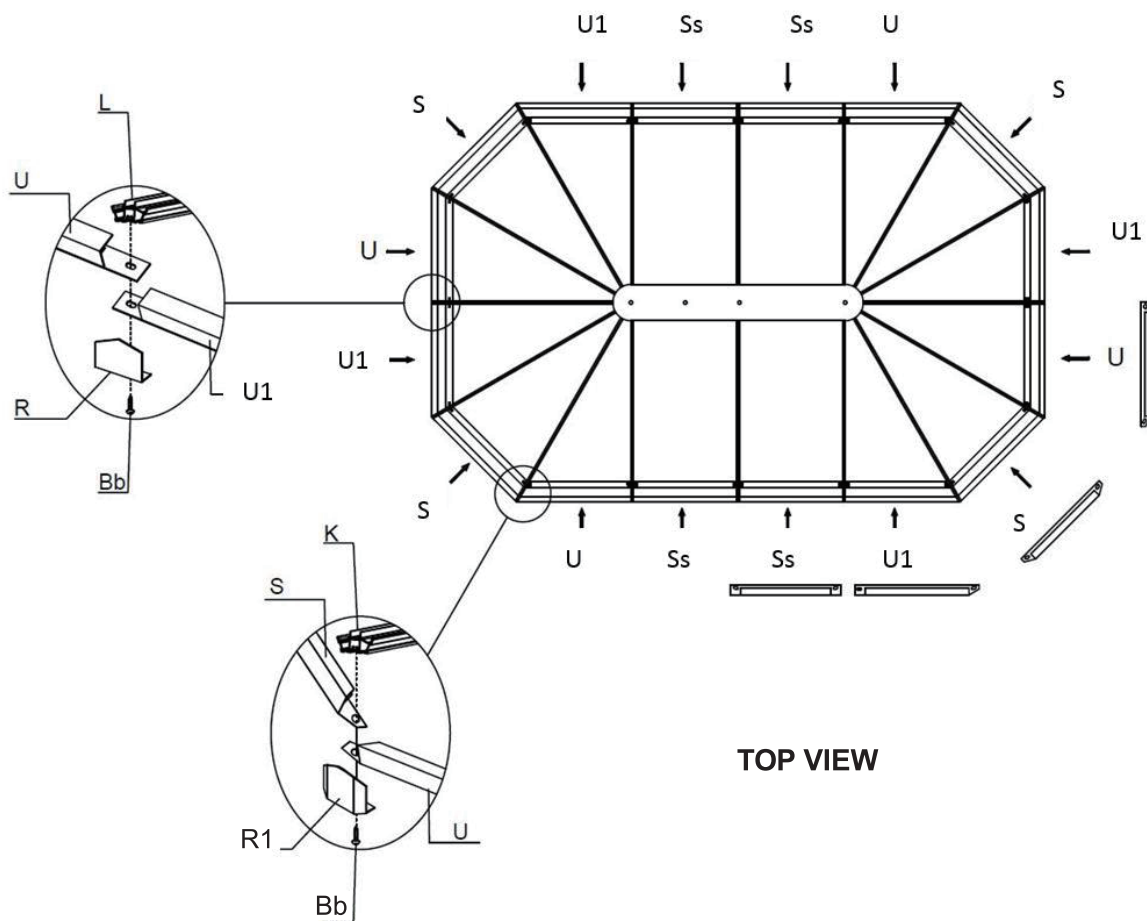

Step 8:

1. From the inside of the solarium, install all the Brackets (Pp/Pp-1) using Bolts (Bb) on the Rafters L & K.
2. From the inside of the solarium, install the Solidifying Bar (T, Tt, V, and V1) as illustrated using the Bolts (Bb).

NOTE :

1. **Make sure all screws/ bolts are tight. But avoid over-tightening as it can damage the threading and head.**

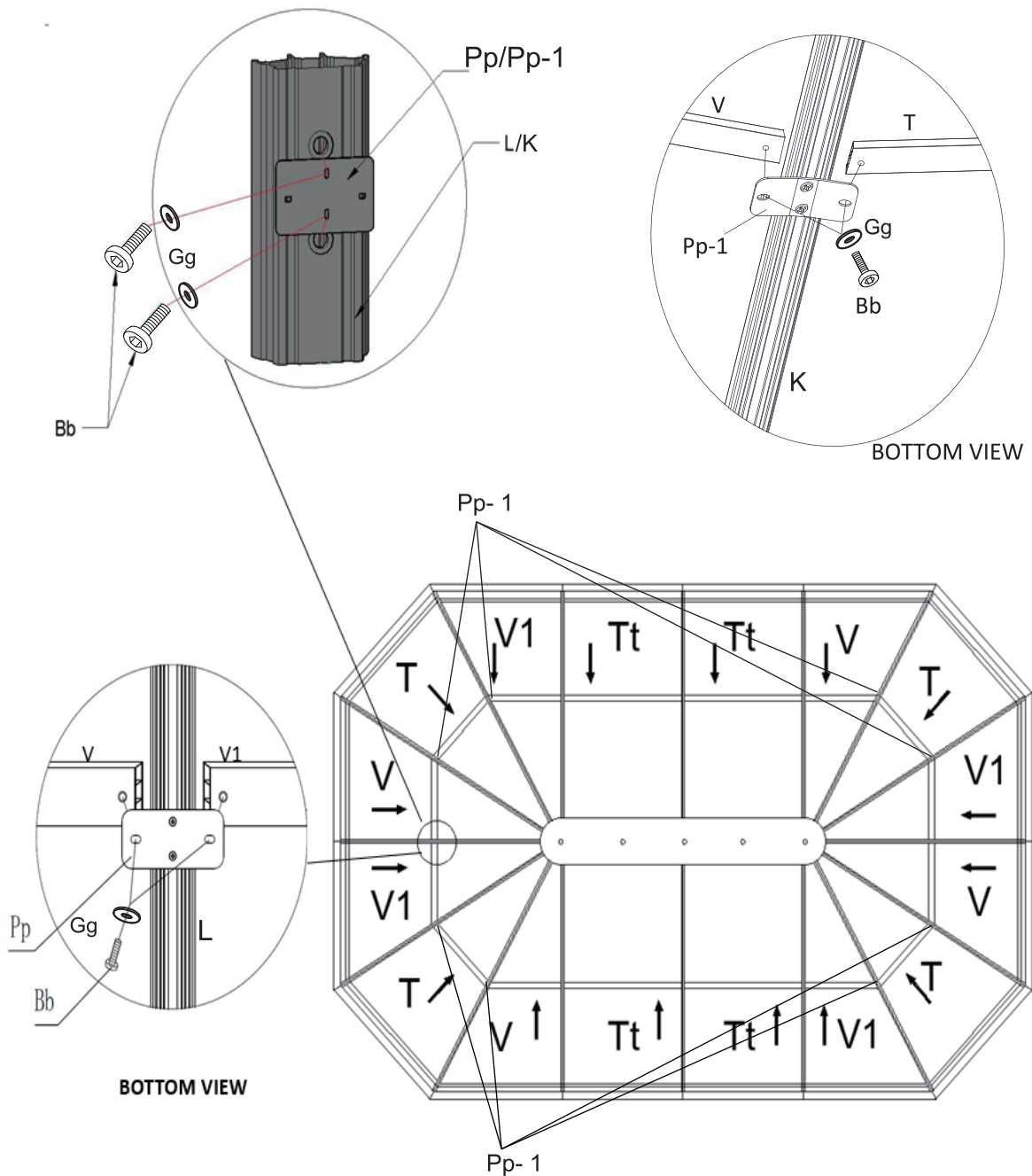

Step 9:

Install the bottom Roof Panels (Jj, Kk, Mm and Rr) by sliding them onto Finishing Bars (S, U, Ss and U1).

NOTE:

1. Please refer to the stickers on how to place the roof panels.
2. Make sure all screws/ bolts are tight.

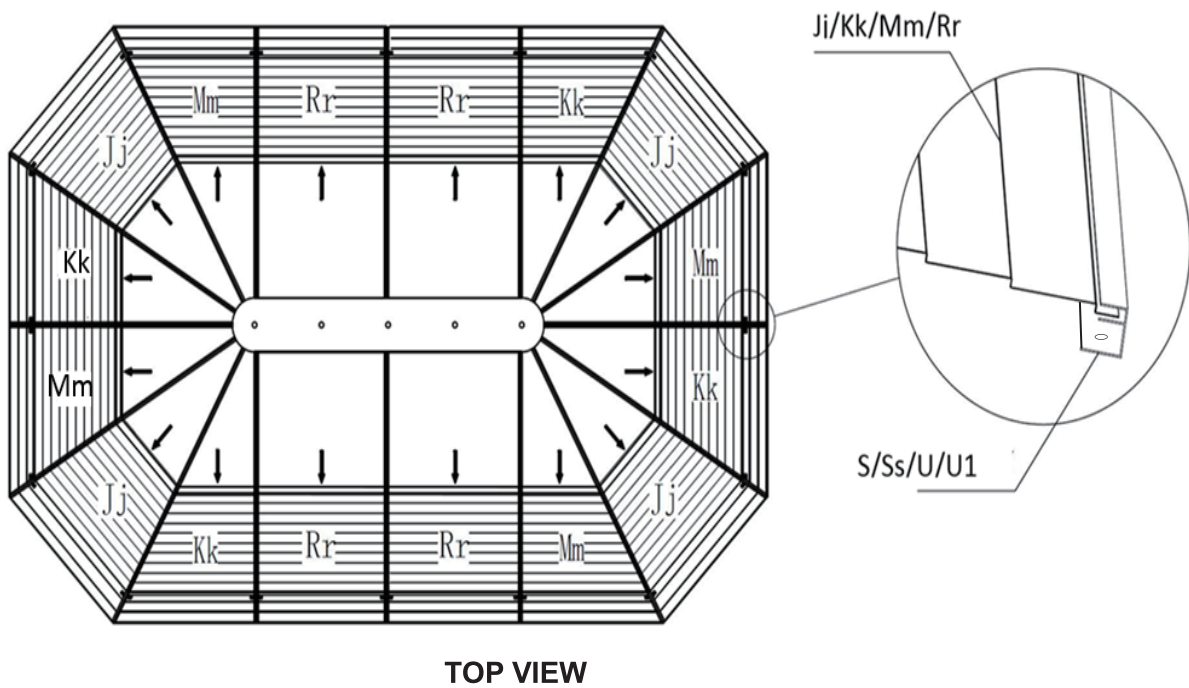

Step 10:

1. Install the upper Roof Panel (Aa) by sliding them on top of roof Rafters (K).

**NOTE: Please refer to the stickers on how to place the roof panels.
Hold panels in position until screwed.**

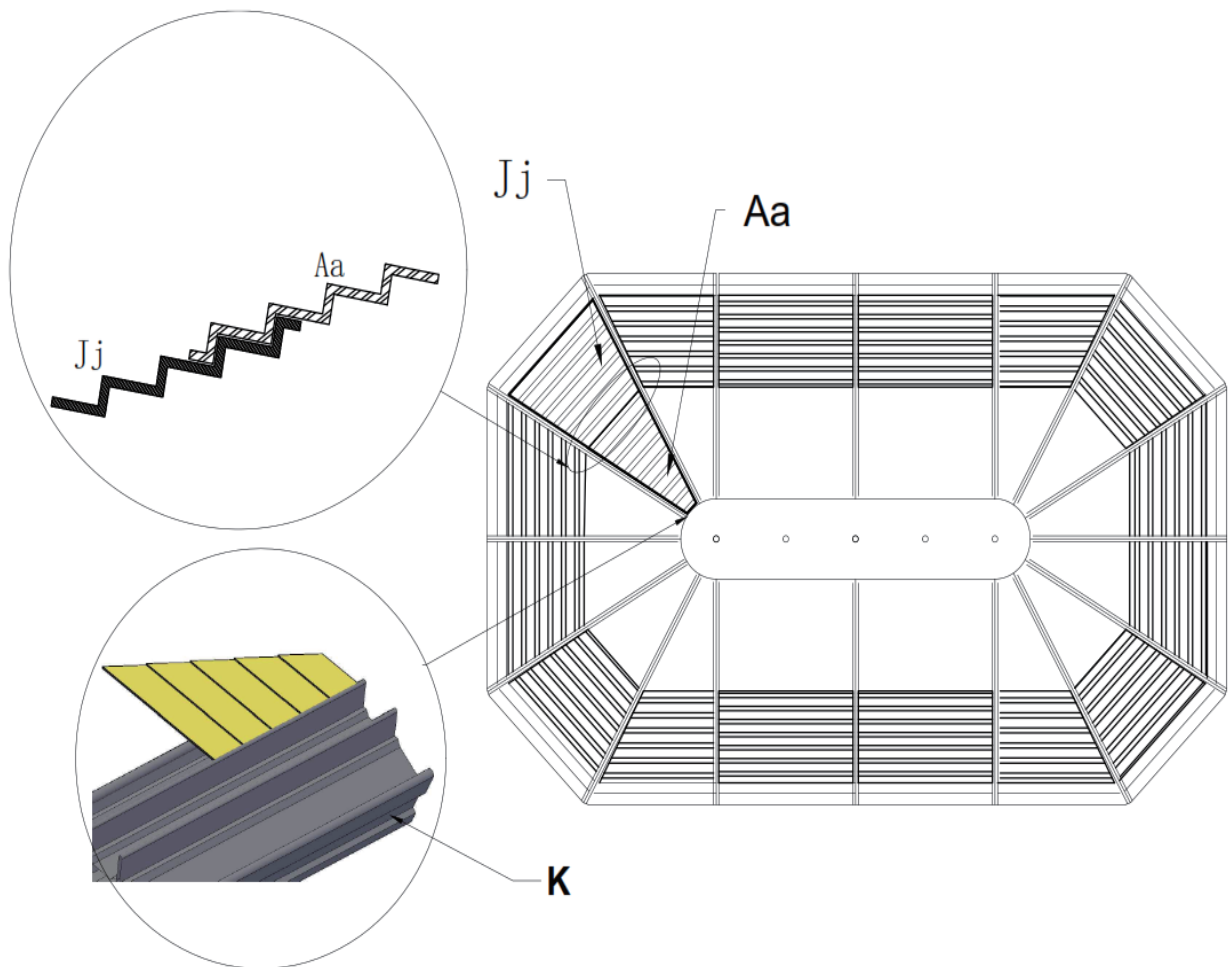

Step 11:

1. Once installation of the Roof Panel (Aa) is complete, affix it using the Cover Roof Bar (O) using the Screws (Oo1) on one side only, then place another roof panel and repeat this step.

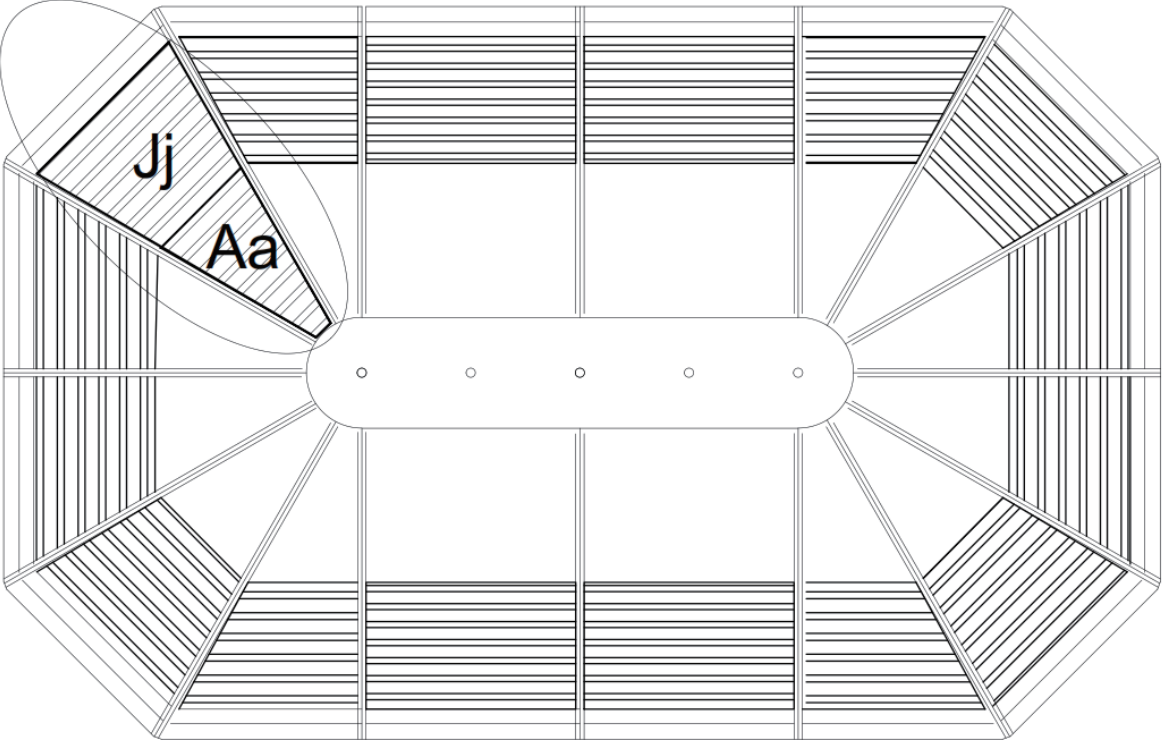
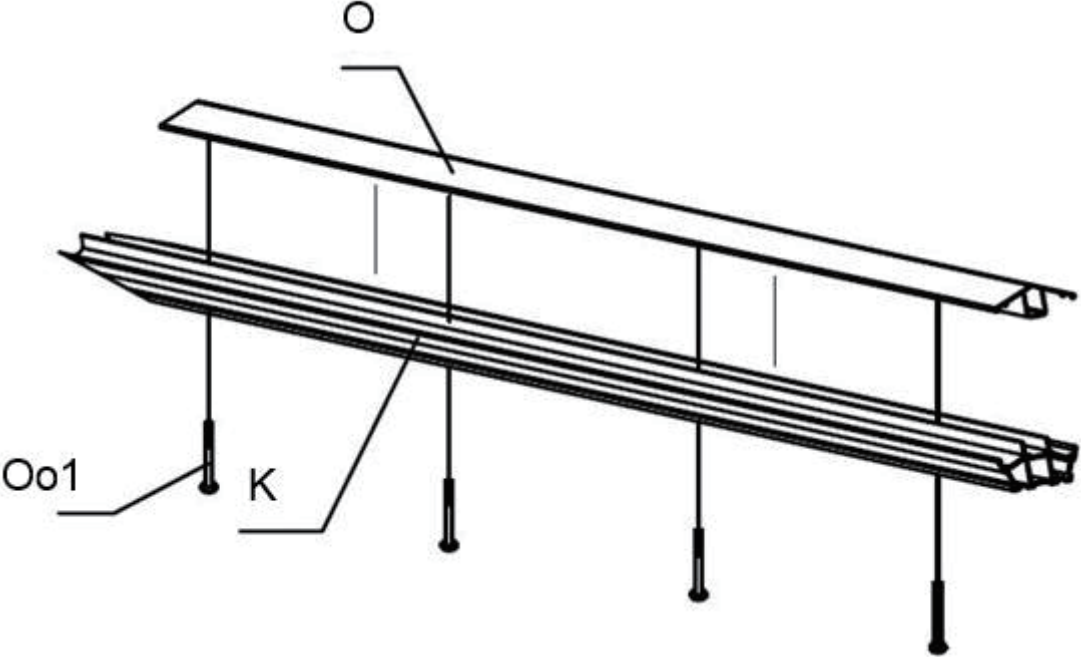

Step 12:

1. Install the Upper Roof Panels (Aa, Ll, Qq, Y) by sliding on top of roof Rafters (K, L) except for one Roof Panel (Qq) while installing Cover Roof Bars (0 & 01).

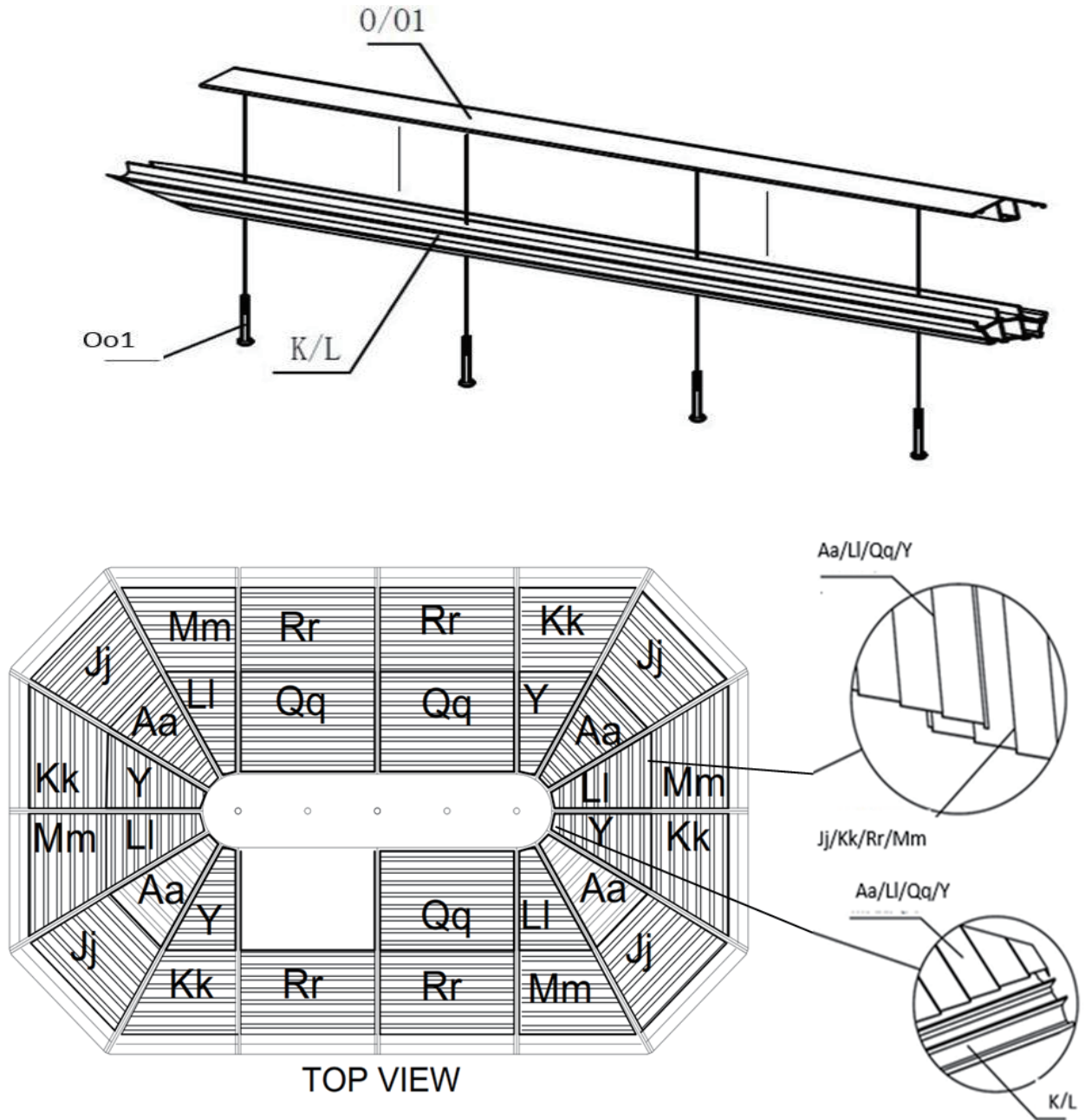

Step 13:

1. Use Nut (Hh) and Washer (Gg) to affix the Top Cap (M) to the Central Hub (N).

NOTE: This is a heavy part and needs to be handled carefully.

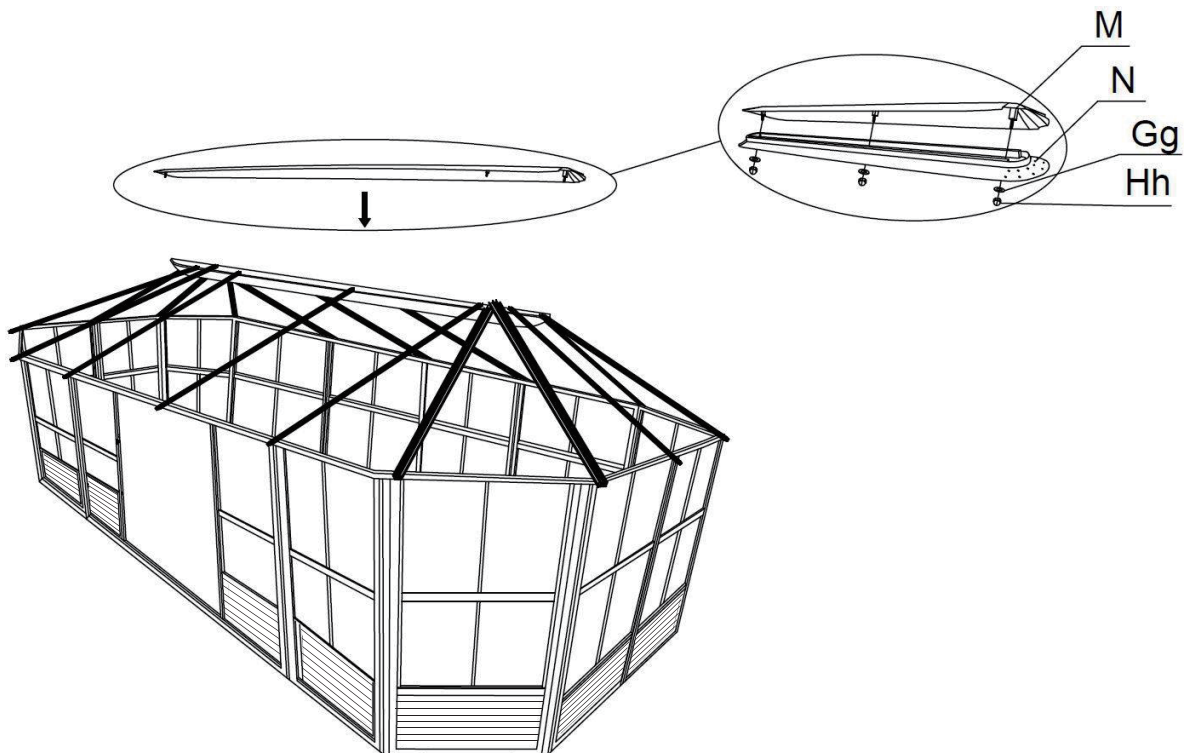

Step 14:

1. Install the last upper Roof Panels (Qq).

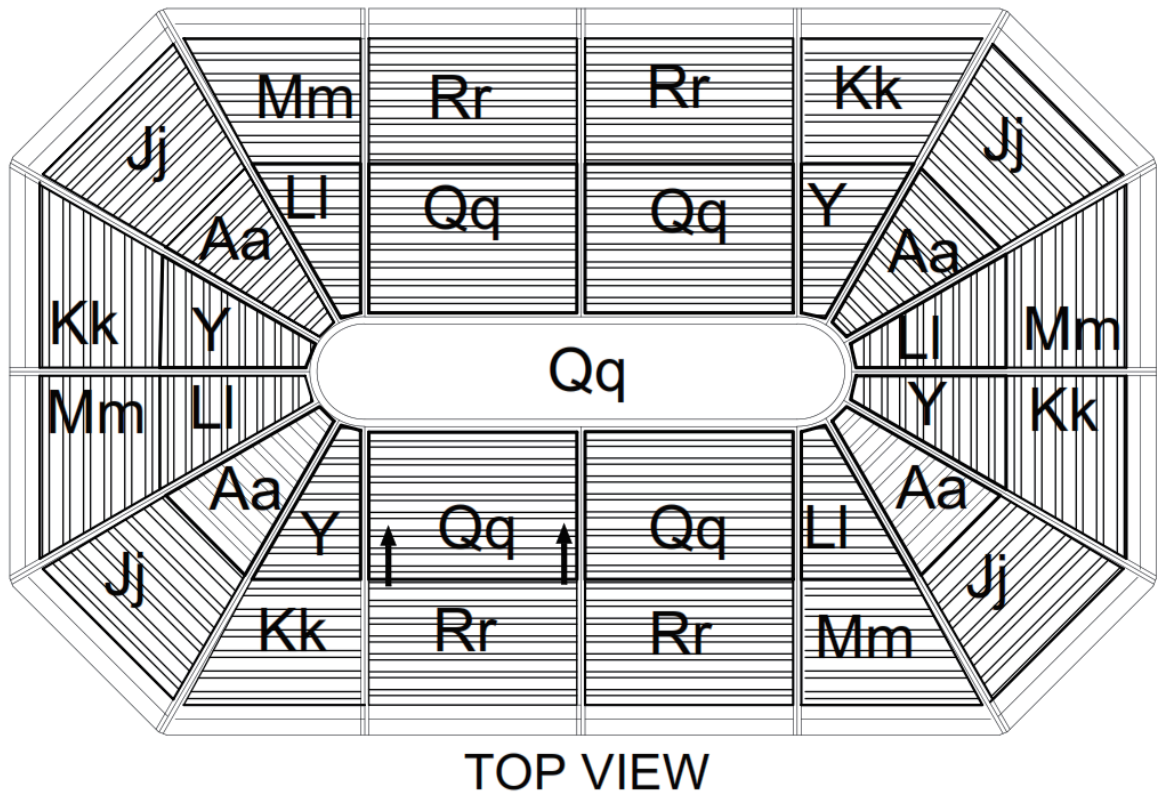

Step 15:

1. Once the last roof panel is installed, screw last Cover for Rafter (O1) to the Rafters (L) with bolt (Oo1).

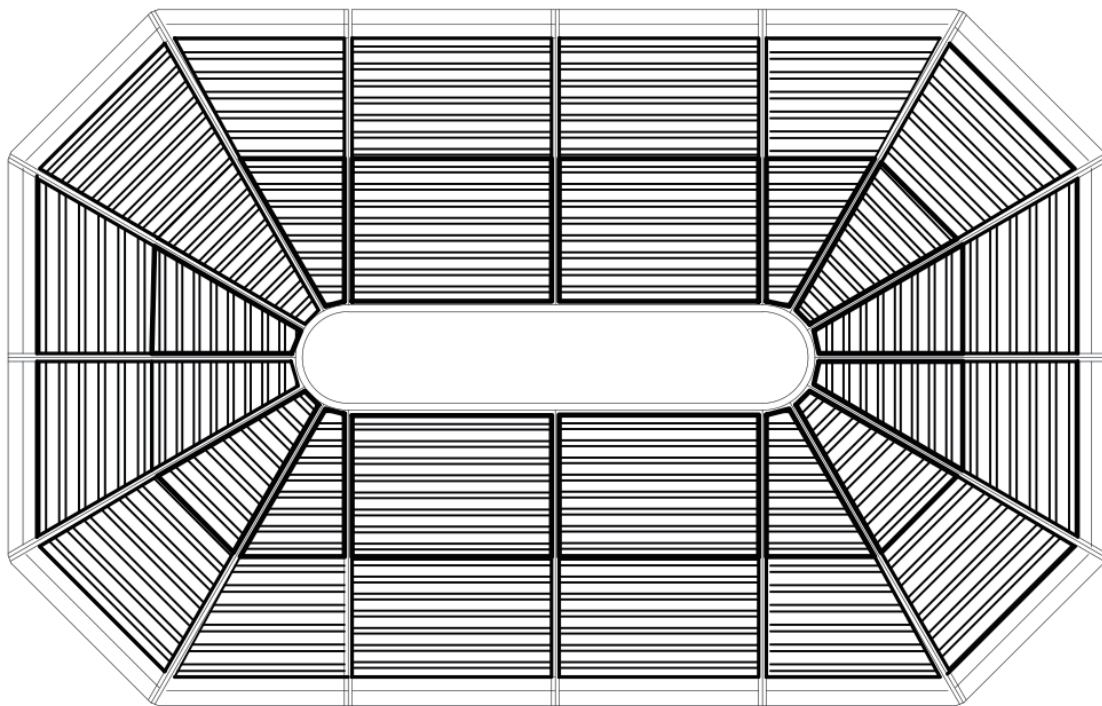
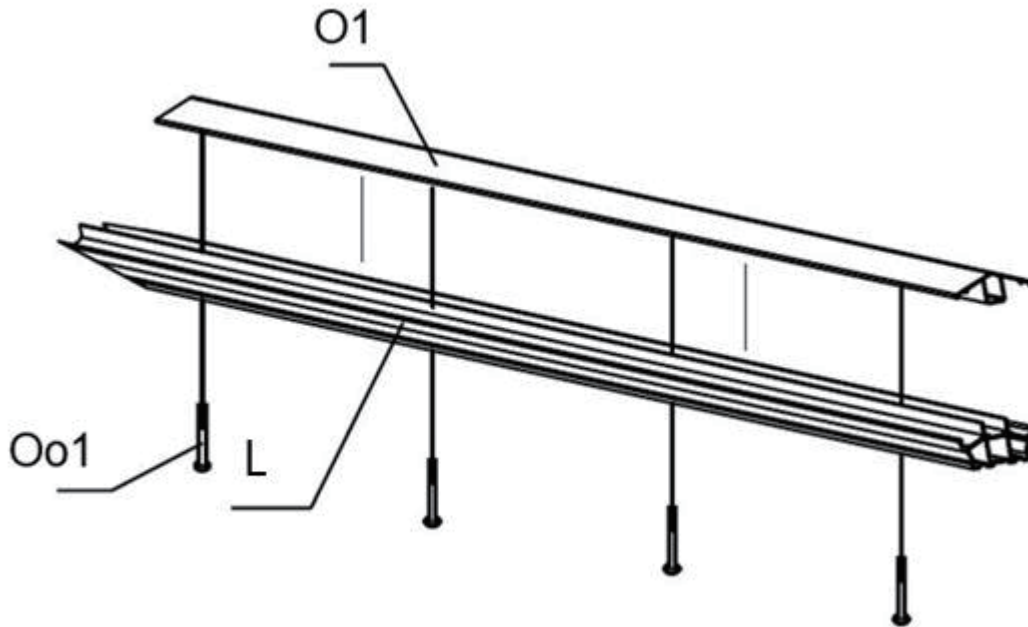

TOP VIEW

***Suggestions**

The below mentioned are only suggestions in order to permit drainage, these will vary depending on your flooring – material, flatness and slope.

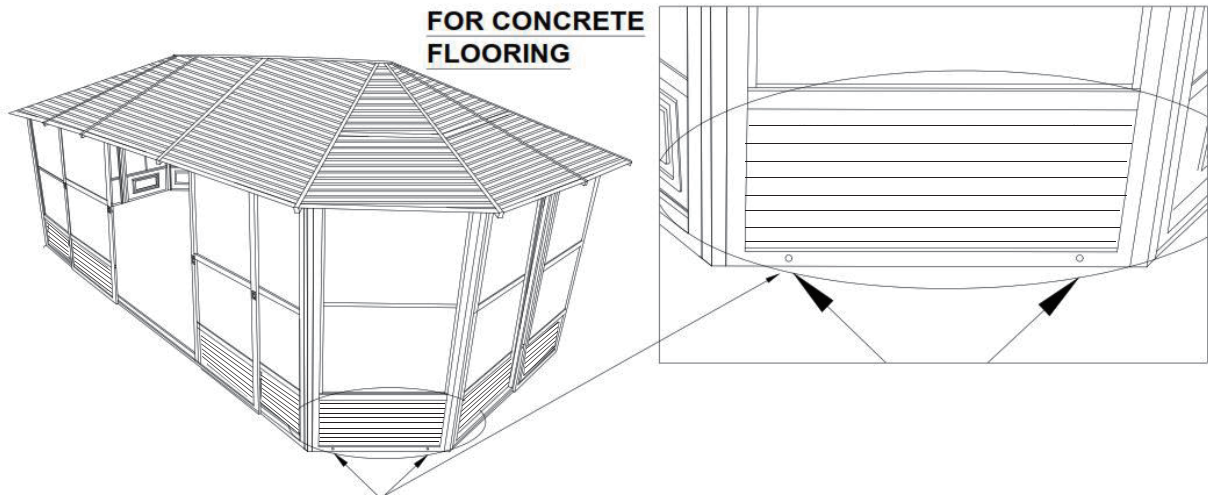

On the outside face, it is suggested to drill holes at the bottom end of the panels to permit drainage when installing on Concrete floor

For Wooden Deck

Drill through the wooden deck where drain holes are located to permit drainage

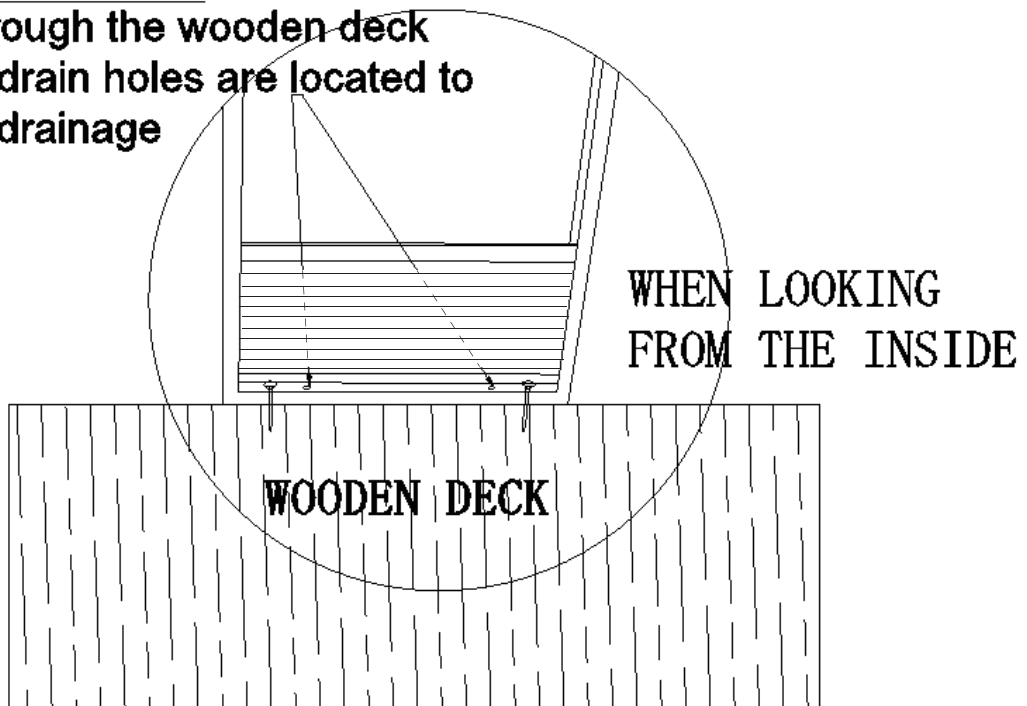

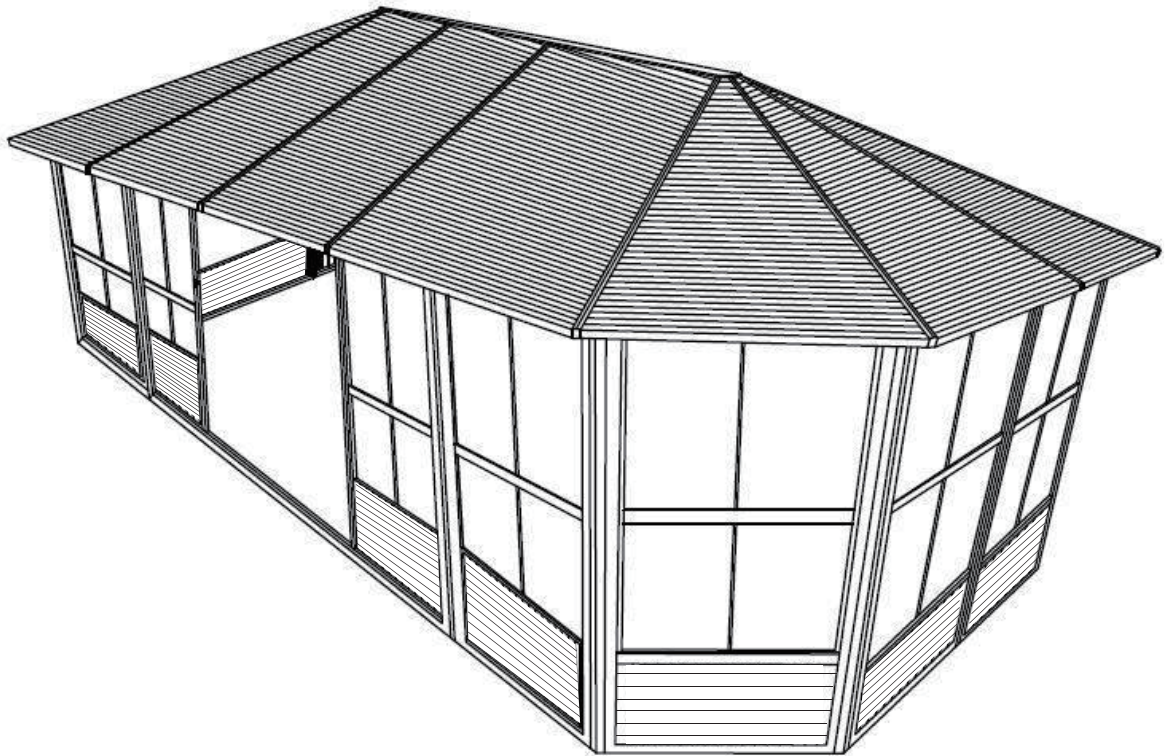
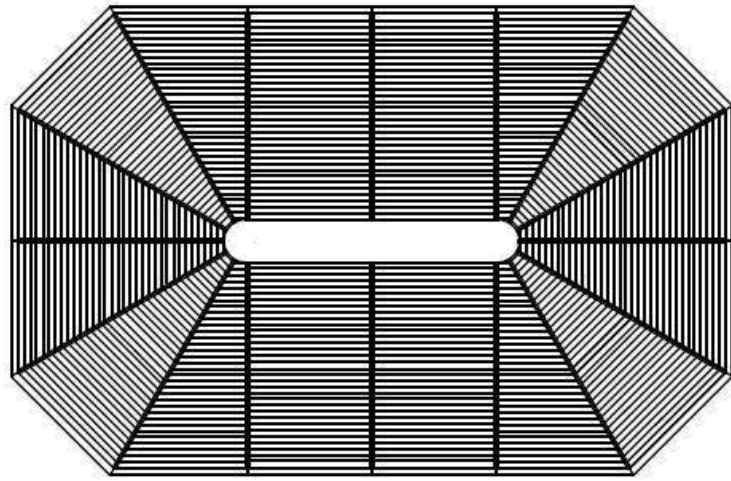

WARRANTY

Carefully inspect the contents of the package to check if any components are missing or damaged. In the event that any parts are missing or damaged, **do not return the product to the place of purchase**; instead, contact Gazebo Penguin's Customer Experience Department.

Montreal: (514) 276-3485

Elsewhere in Canada and the United States: 1-800-737-7174

info@gazebopenguin.com

This product has been designed and manufactured to meet the highest standards of quality and durability. It is warranted against defects in material and/or workmanship as subjected in the «Warranty Limitations and exclusions» listed below:

- 1 YEAR ON MANUFACTURING DEFECTS

In the event that the product is damaged or the warranty period has expired, please contact Gazebo Penguin's Customer Experience Department for a complete list of replacement parts and prices.

WARRANTY LIMITATIONS AND EXCLUSIONS

- 1. Uncovered Damages:** This warranty does not cover damages caused by wind, falling objects, fire, animals, vegetation, vandalism, extreme weather conditions, or collapses due to the accumulation of snow and/or ice.
- 2. Roof Maintenance:** The roof must remain free of snow and ice accumulation. Such accumulation must be removed in five-foot (5') sections from right to left. Damages resulting from lack of roof maintenance are not covered under the warranty.
- 3. Snow and Ice Removal:** Removing snow or ice from inside the product is prohibited, as it may damage the product.
- 4. Positioning:** It is advised not to place the product near buildings or trees, as snow and/or ice may slide off and accumulate on the roof, causing excessive weight.
- 5. Installation:** The warranty is valid only if the product is installed according to the instructions provided by Gazebo Penguin. Improper installation, including inadequate anchoring, voids the warranty..
- 6. Water Infiltration:** Water infiltration may occur during heavy rains. Refer to the instruction manual for window positioning and information on water drainage.
- 7. Replacement Clause:** We reserve the right to repair or replace any defective product or part at our sole discretion.
- 8. Modifications:** Any modification or addition to the product voids the warranty.