



MANUEL D'INSTRUCTIONS

INSTRUCTION MANUAL





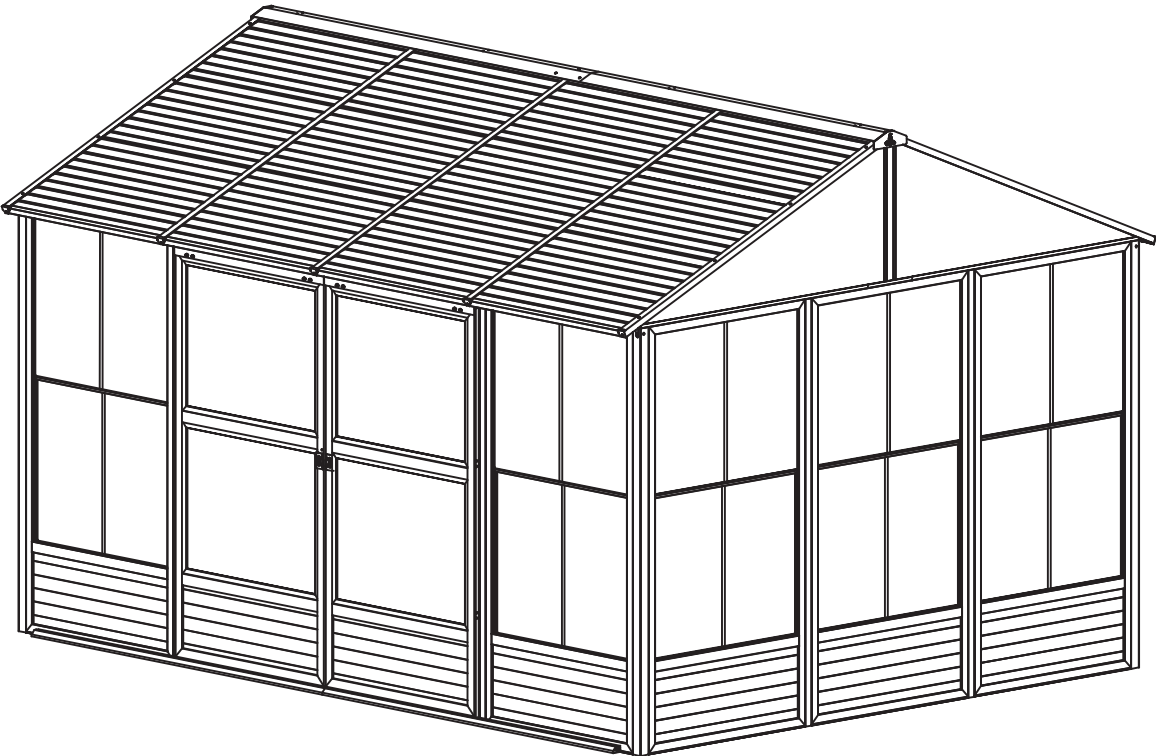

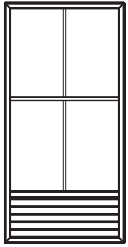
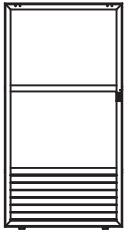

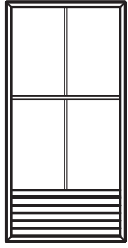
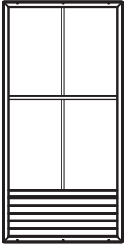
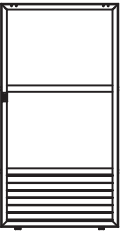
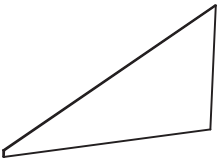
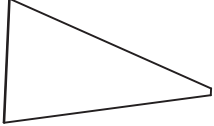













MYRDAL SOLARIUM 11X14 TOIT EN MÉTAL
MYRDAL SOLARIUM 11X14 METAL ROOF











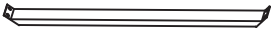







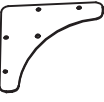



info@gazebopenguin.com 1-800-737-7174	sku: 81114MR-42	
--	-----------------	--











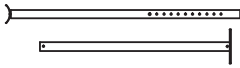









PART	PACKED IN BOX	QTY	DIAGRAM	PART	PACKED IN BOX	QTY	DIAGRAM
25-311 Regular Frame A1 Cadre régulier A1	1	6		25-315 Sliding Door B3 Porte coulissante B3	1	1	

PART	PACKED IN BOX	QTY	DIAGRAM	PART	PACKED IN BOX	QTY	DIAGRAM
25-311 Regular Frame A1 Cadre régulier A1	2	4		25-312 Frame Next To Door (Additional Holes) A2 Cadre Adjacent à la porte (Trous additionnels) A2	2	2	
25-316 Sliding Door B4 Porte coulissante B4	2	1		25-351 Acrylic Board (Left Side) R Panneau en acrylique (Côté gauche) R	2	2	
25-352 Acrylic Board (Right Side) R1 Panneau en acrylique (Côté droit) R1	2	2					



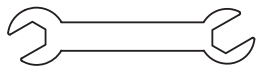

PART	PACKED IN BOX	QTY	DIAGRAM	PART	PACKED IN BOX	QTY	DIAGRAM
25-319 Bottom Roof Connector C2 Connecteur de toit inférieur C2	3	2		25-320 Roof Cap C3 Capuchon de toit C3	3	2	
25-321 Connecting Piece D Pièce de connection D	3	18		25-322 Corner Connecting Piece E Pièce de connection en Coin E	3	4	
25-323 Inner Corner Connecting Piece E1 Pièce de connection en coin intérieur E1	3	4		25-326 Bottom Door Track F1 Rail de porte inférieur F1	3	2	
25-327 Left Upper Door Track G1 Rail de porte supérieur gauche G1	3	1		25-328 Right Upper Door Track G2 Rail de porte supérieur droit G2	3	1	
25-329 Door Frame Reinforcing Bar1 G5 Barre de solidification du cadre de porte1 G5	3	1		25-330 Door Frame Reinforcing Bar1 G6 Barre De solidification du cadre de porte1 G6	3	1	
25-331 Metal Edging 1 H Barre de finition en métal 1 H	3	8		25-332 Metal Edging 2 H1 Barre de finition en métal 2 H1	3	8	
25-334 Tube 1 For Regular Door Frame I2 Tube 1 pour cadre de porte régulier I2	3	1		25-335 Tube 2 For Regular Door Frame I3 Tube 2 pour cadre de porte régulier I3	3	2	
25-336 Tube 3 For Regular Door Frame I4 Tube 3 pour cadre de porte régulier I4	3	1		25-337 Edging 1 J Barre de finition latéral 1 J	3	4	
25-338 Edging 2 J1 Barre de finition latéral 2 J1	3	4		25-339 Roof Support Bar K Support de toit K	3	2	
25-340 Tube For Transparent Acrylic Board Left L1 Tube pour panneau en acrylique transparent gauche L1	3	2		25-341 Tube For Transparent Acrylic Board Right L2 Tube pour panneau en acrylique transparent droit L2	3	2	
25-342 Middle Rafter M Chevron central M	3	6		25-343 Side Rafter M1 Chevron latéral M1	3	4	

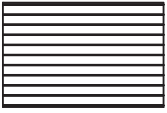
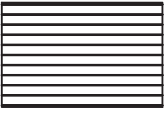
PART	PACKED IN BOX	QTY	DIAGRAM	PART	PACKED IN BOX	QTY	DIAGRAM
25-346 Roof Support Bar 2 O Barre De Support de toit 2 O	3	2		25-347 Mosquito Bar 1 P1 Barre anti-moustiques 1 P1	3	2	
25-348 Mosquito Bar 2 P2 Barre anti-moustiques 2 P2	3	2		25-349 Mosquito Bar 3 P3 Barre anti-moustiques 3 P3	3	2	
25-350 Side Rafter Cover Bar Q Couvert Latéral de chevron Q	3	4		25-366 Bar For Acrylic Board 1 U Barre pour panneau en acrylique 1 U	3	4	
25-367 Bar For Acrylic Board 2 U1 Barre pour panneau en acrylique 2 U1	3	4		25-368 Bar For Acrylic Board 3 U2 Barre pour panneau en acrylique 3 U2	3	4	
25-369 Reinforcing Panel Connector V Pièce de connexion renforcée pour panneau V	3	4		25-371 Door Handle V2 Poignée de porte V2	3	1	
25-372 Reinforcing Rafter Bar W Barre de renforcement de chevron W	3	3		25-373 Bar For Botton Roof Cap Y Barre pour capuchon de toit inférieur Y	3	8	
25-376 Connecting Roof Piece Z3 Pièce de connexion de toit Z3	3	2		25-377 Middle Rafter Connecting Piece Z4 Pièce de connexion du chevron central Z4	3	6	
25-378 Side Rafter Connecting Piece Z5 Pièce de connexion du chevron latéral Z5	3	4		25-379 Metal Connecting Piece 1 Z6 Pièce De connexion en métal 1 Z6	3	8	
25-380 Metal Connecting Piece 2 Z7 Pièce De connexion en métal 2 Z7	3	12		25-381 Roof Side Cap Z8 Capuchon latéral de toit Z8	3	2	
25-382 Rafter Cap Z9 Couvert de chevron Z9	3	10		25-383 Door Wheel B5 Roulette de porte B5	3	4	
25-385 Door Stopper B8 Butoir de porte B8	3	4		25-386 Door Cover B9 Couvert de porte B9	3	2	

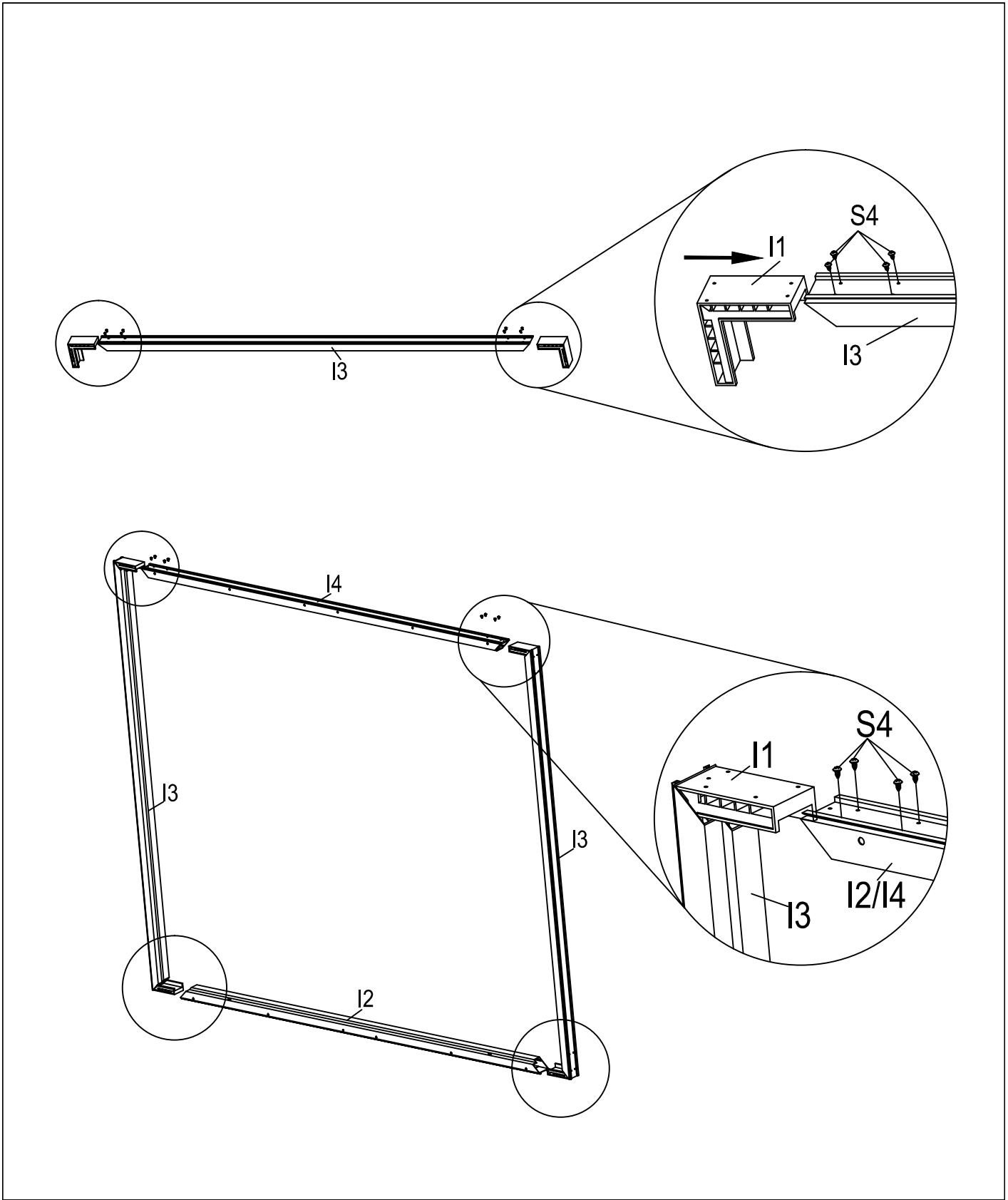
PART	PACKED IN BOX	QTY	DIAGRAM	PART	PACKED IN BOX	QTY	DIAGRAM
25-391 Winter Support Bar WE Barre de support d'hiver WE	3	2		25-353 Screw M6X15 S Vis M6X15 S	3	156	 M6X16
25-354 Screw St4. 2X25 S1 Vis St4.2X25 S1	3	36	 ST4.2X25	25-355 Screw M6X15+Nut S2 Vis M6X15 avec écrou S2	3	13	 M6X16
25-356 Screw M6X15 + Cap Net S3 Vis M6X15 avec écrou borgne S3	3	5	 M6X10	25-357 Screw St4.2X16 S4 Vis St4.2X16 S4	3	36	 ST4.2X16
25-358 Screw St3.5X16 S5 Vis St3.5X16 S5	3	12	 ST3.5X16	25-359 Screw M6X60 S6 Vis M6X60 S6	3	8	 M6X60
25-360 Screw M4X6 S8 Vis M4X6 S8	3	32	 M4X6	25-361 Screw M4 S9 Vis M4 S9	3	32	 M4
25-374 Screw M6X50+Cap+ Cap 1 Z1 Vis M6X50 avec rondelle et écrou borgne 1 Z1	3	4	 M6X50	25-375 Screw M6X50+ Nuts Z2 Vis M6X50 avec écrou Z2	3	12	 M6X50
25-387 Screw For Door B10 Vis de porte B10	3	8	 M6X35	25-390 Hook WA Crochet WA	3	3	 M6X20
25-392 Screw For Winter Bar WS Vis pour barre de support d'hiver WS	3	2	 M6X50	25-388 Allen Key G3 Clé Allen G3	3	1	
25-389 Allen Key G4 Clé Allen G4	3	1		25-333 Plastic Piece For Regular Frame I1 Pièce en plastique cadre régulier I1	3	4	
25-396 Screw M6X16+ Washer B6 Vis M6X16+ Rondelle B6	3	4	 M6X16				

PART	PACKED IN BOX	QTY	DIAGRAM	PART	PACKED IN BOX	QTY	DIAGRAM
25-364 Metal Roof Panel 1 T2 Panneau de toit en métal 1 T2	4	12		25-365 Metal Roof Panel 2 T3 Panneau de toit en métal 2 T3	4	12	



 <p>I2 X1</p>	 <p>I3 X2</p>	
 <p>I4 X1</p>	 <p>I1 X4</p>	 <p>S4 X32</p>

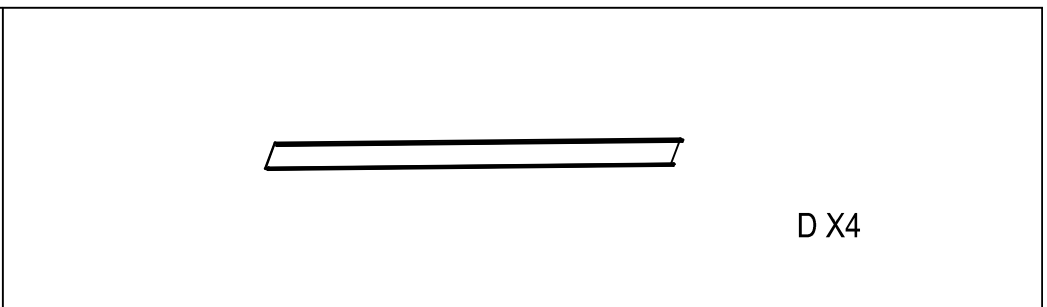
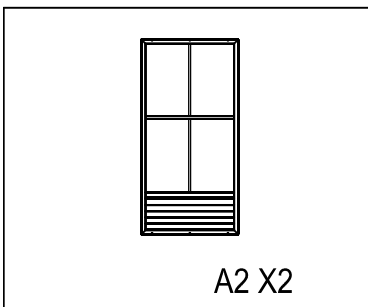
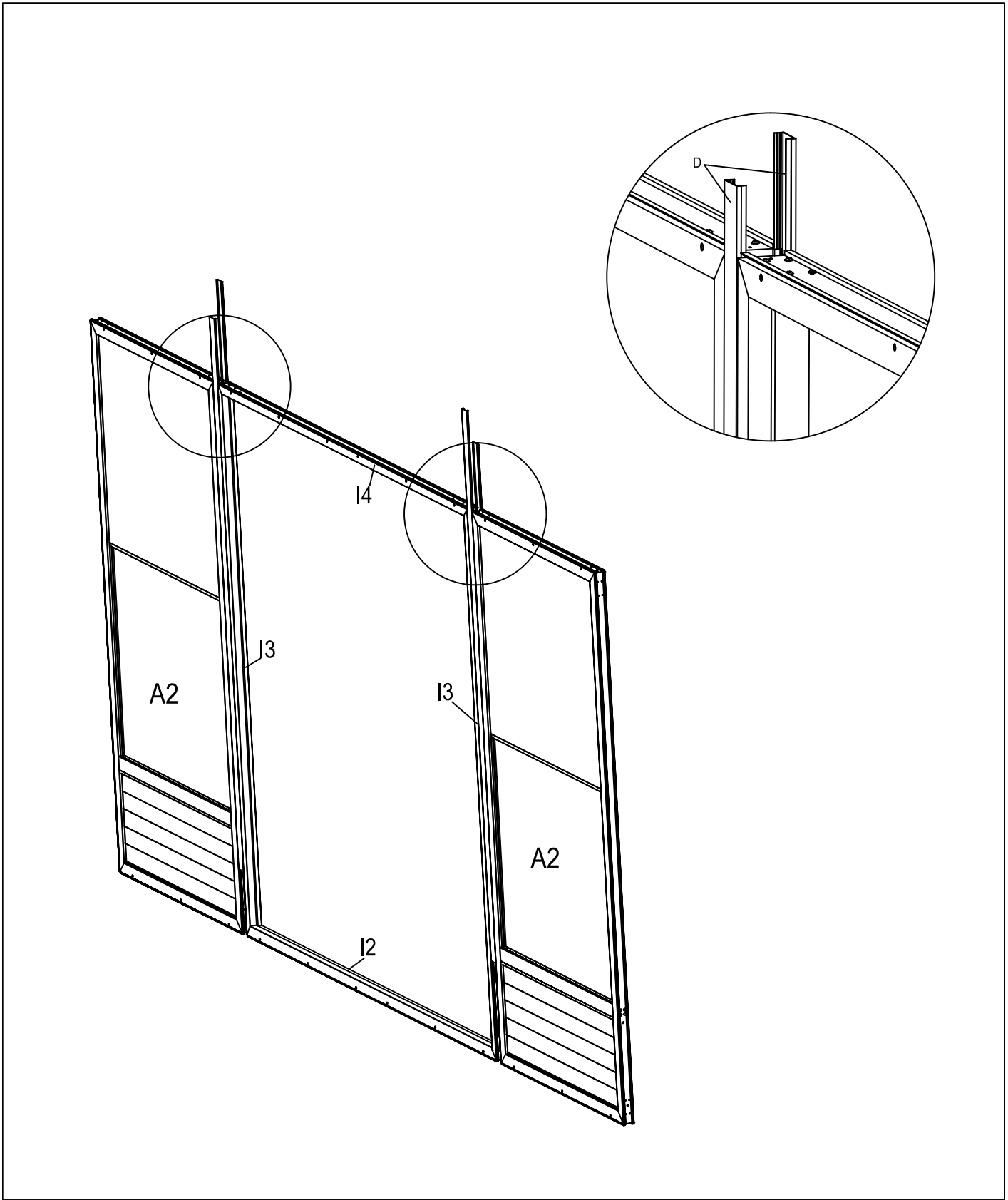

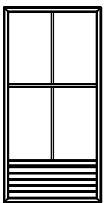
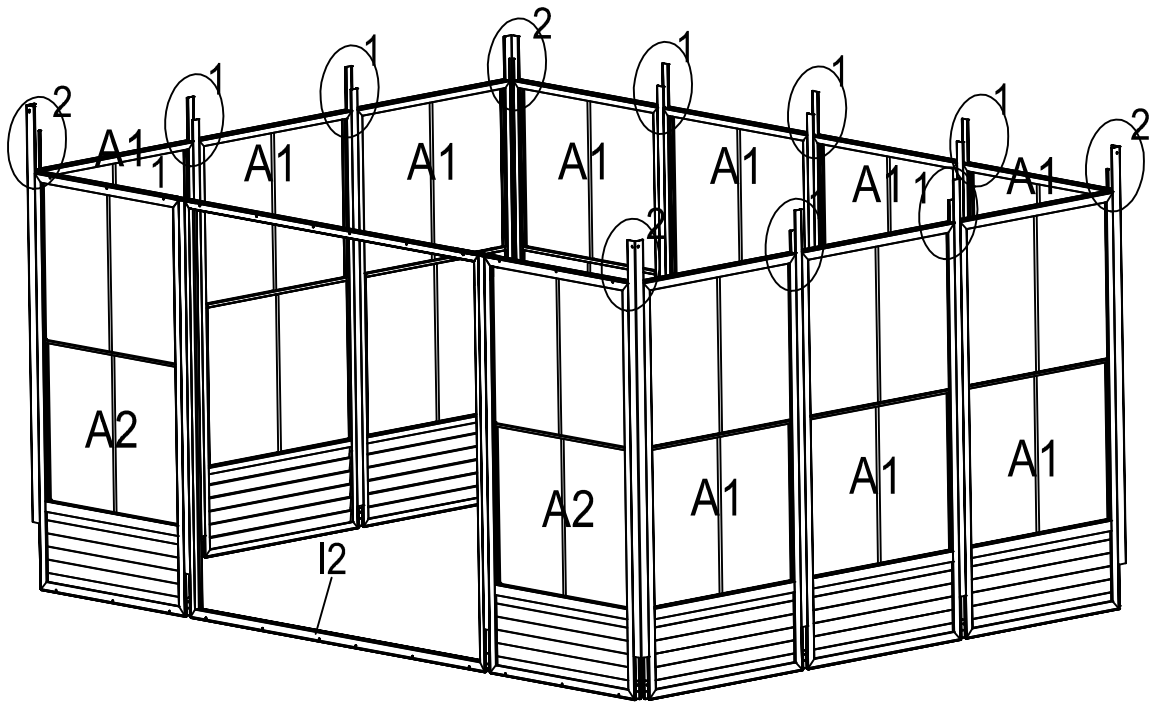
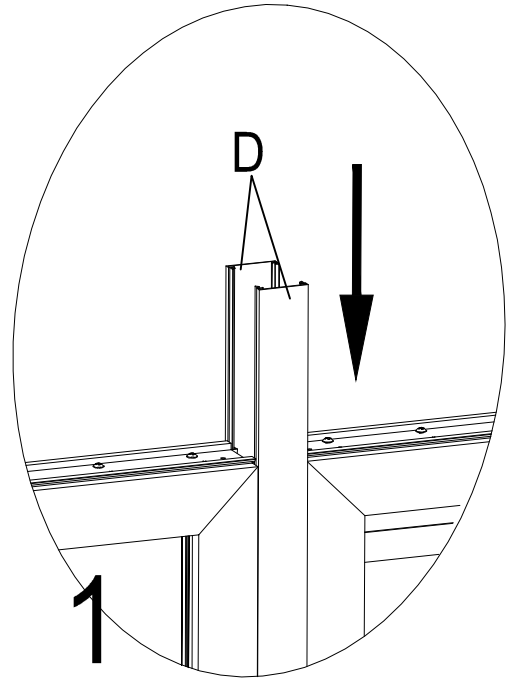
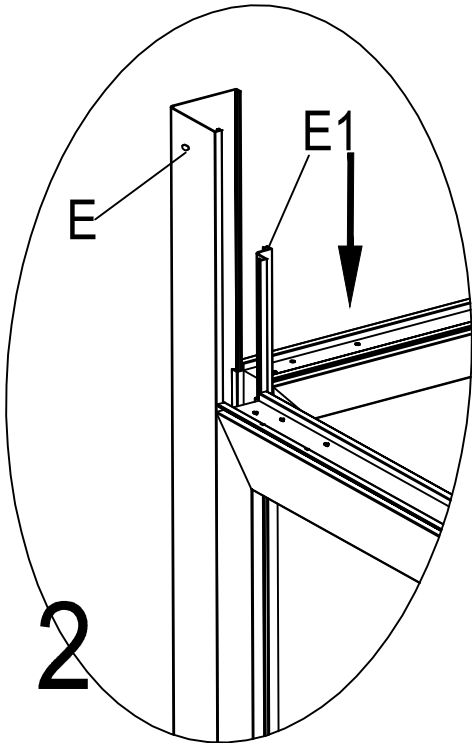

A1 X10



E X4



E1 X4

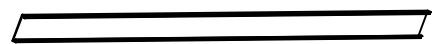

D X14

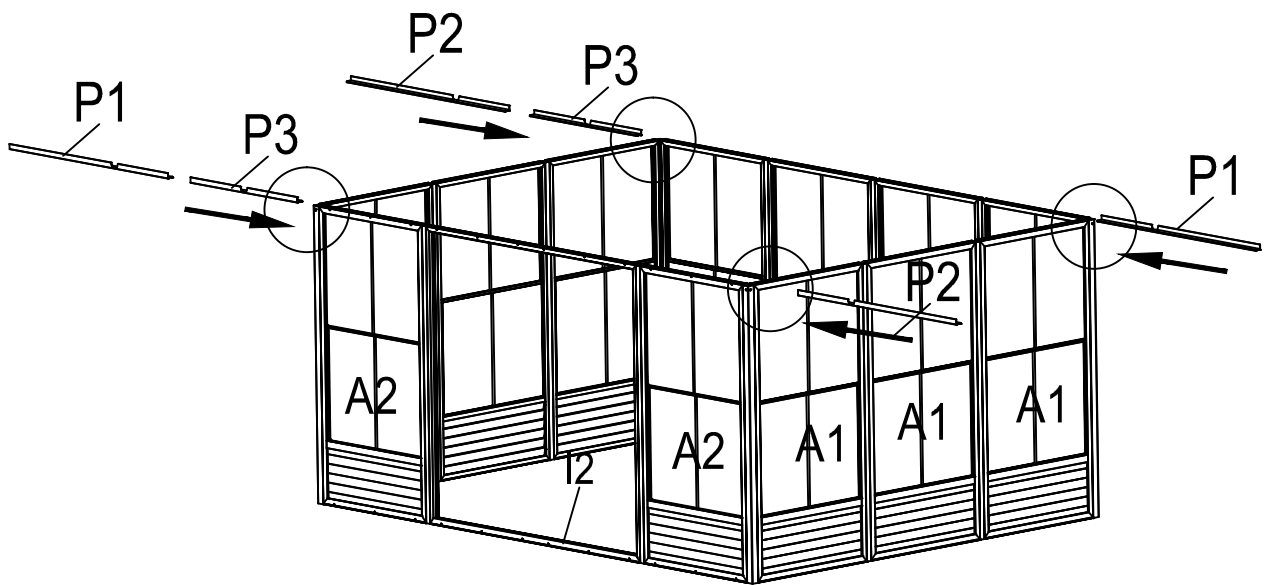
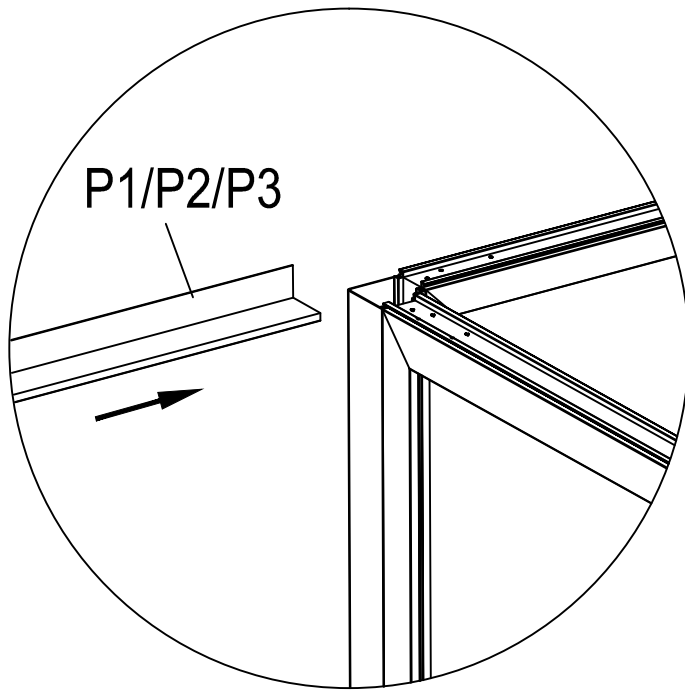

P1 X2

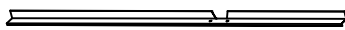

P2 X2

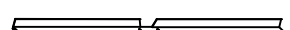

P3 X2

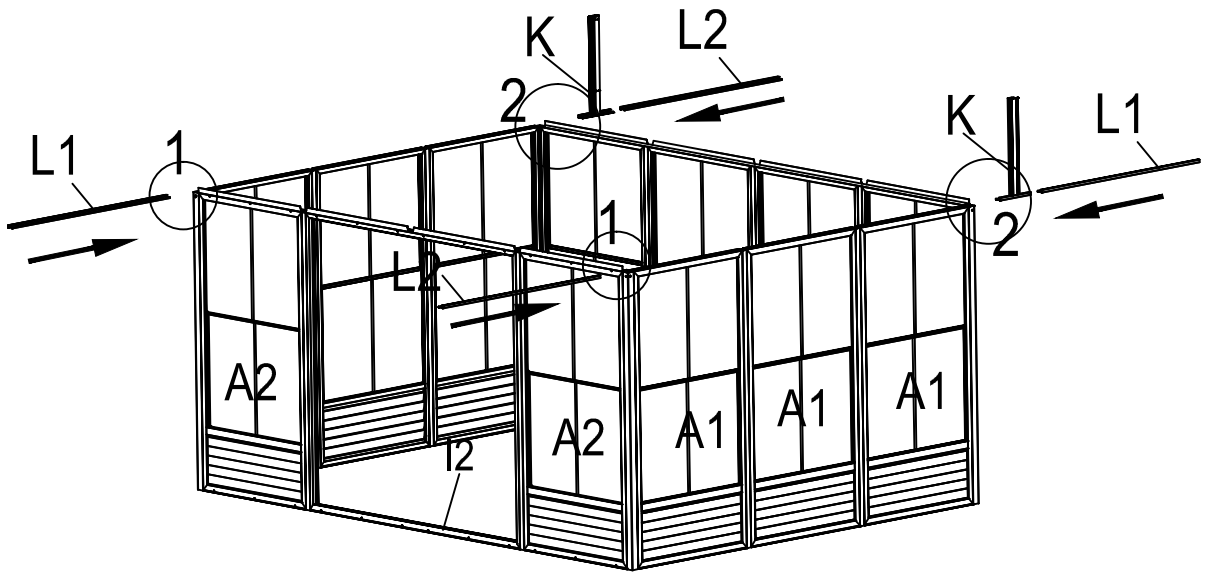
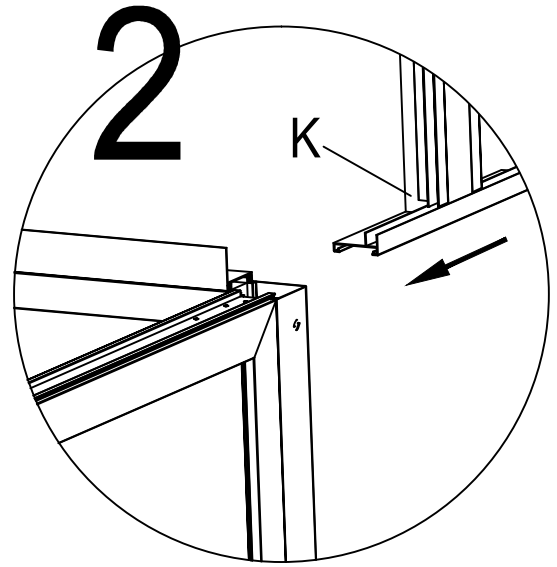
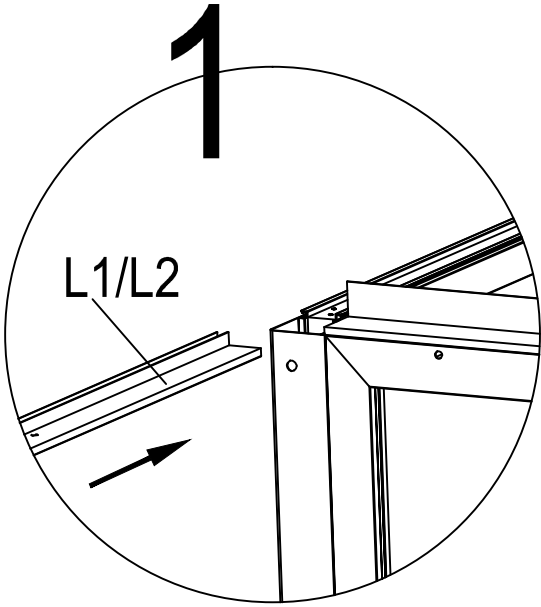

K X2

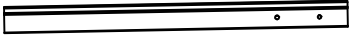

L1 X2

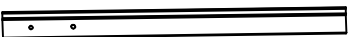

L2 X2

1

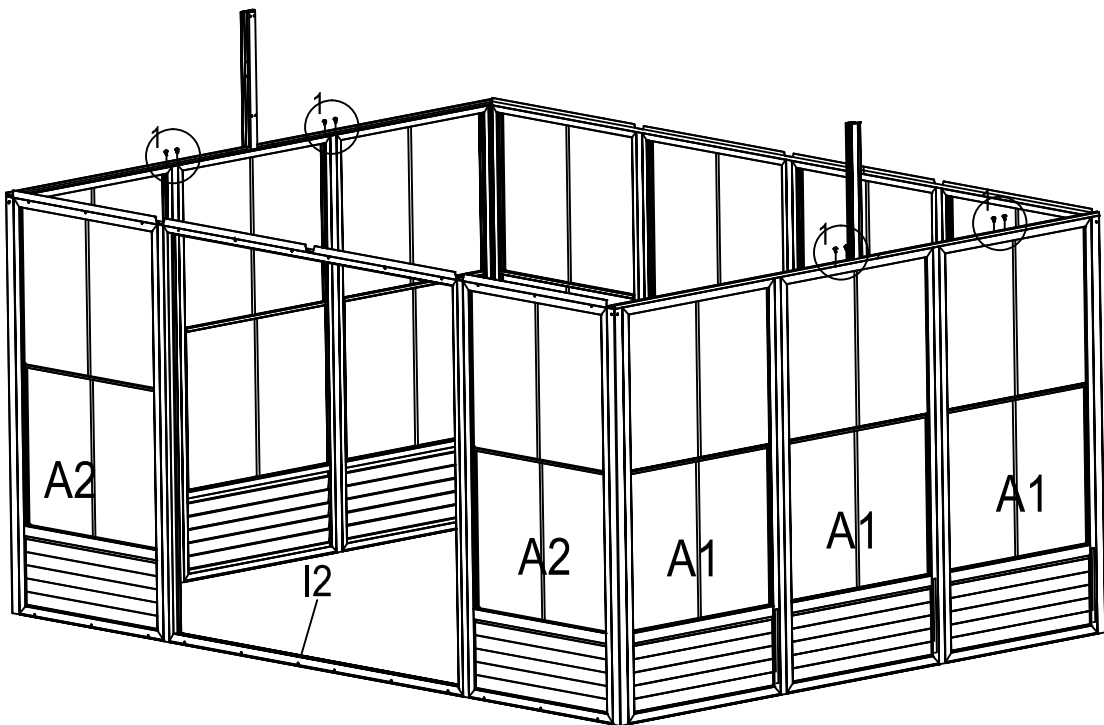
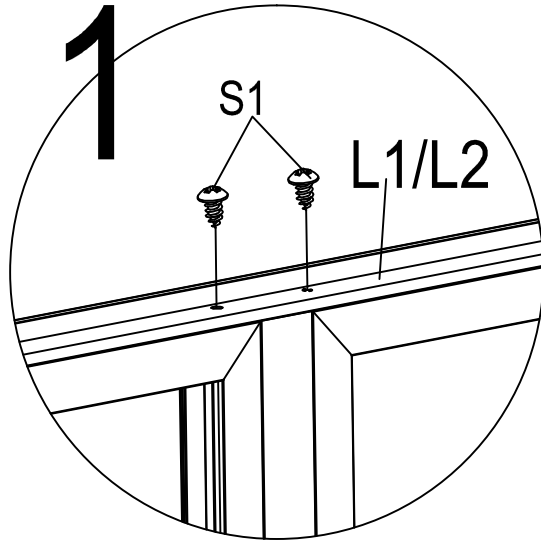

S1 X8

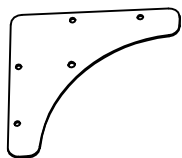
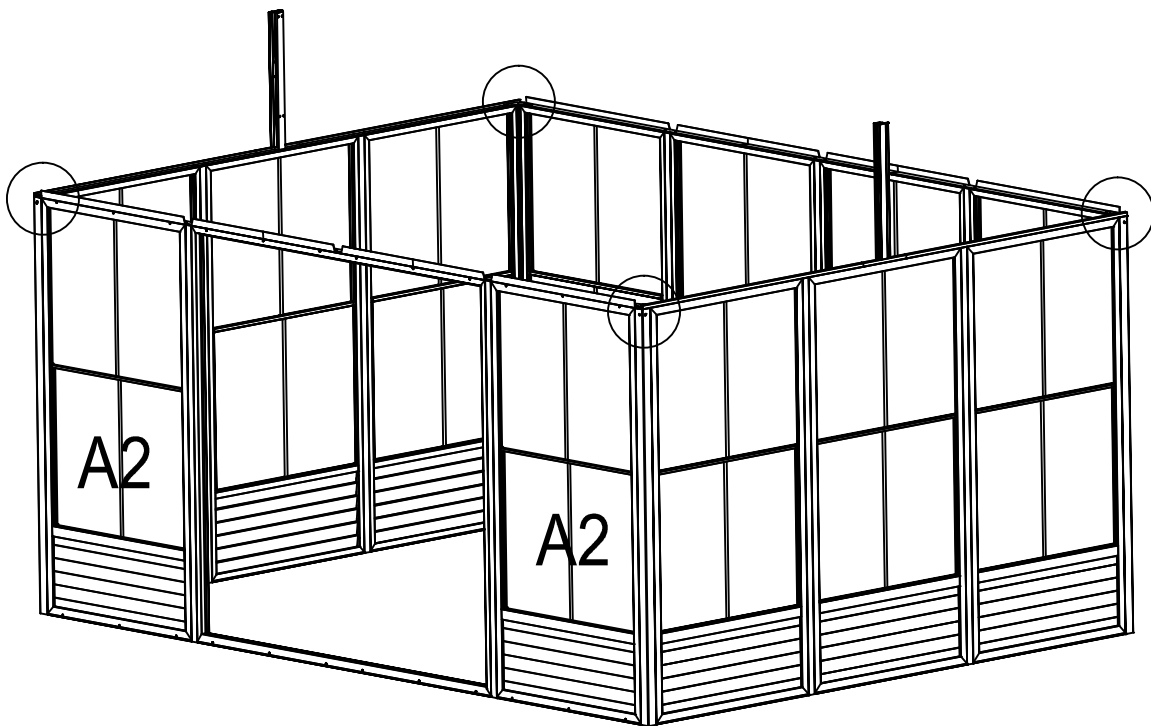
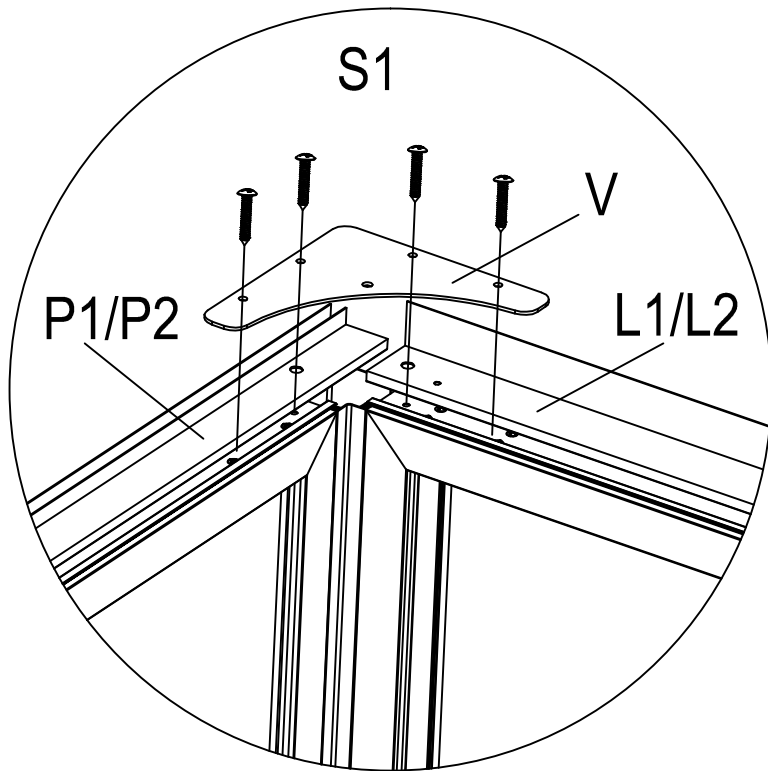



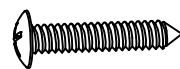

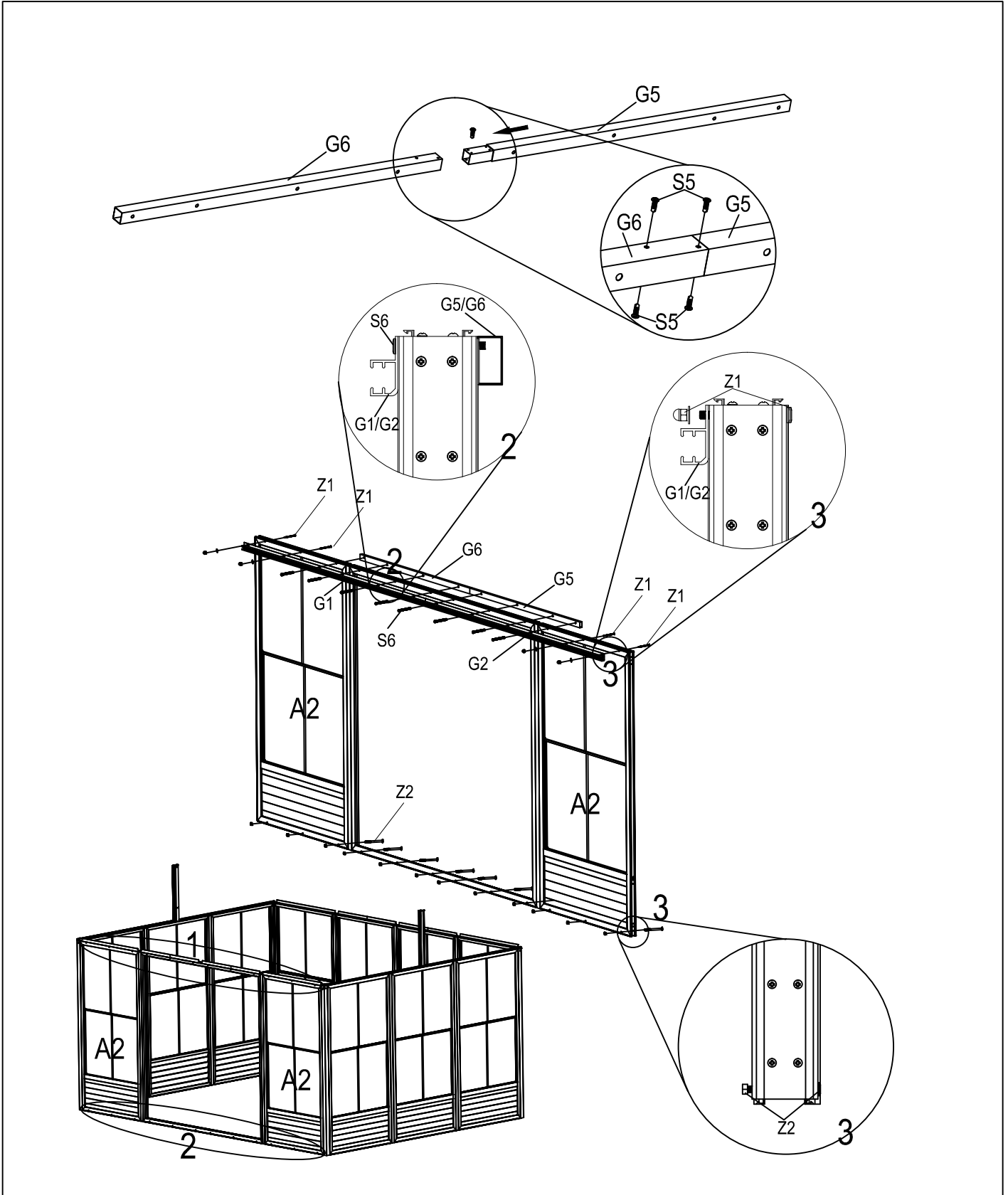

V X4

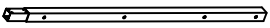



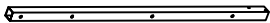

S1 X16

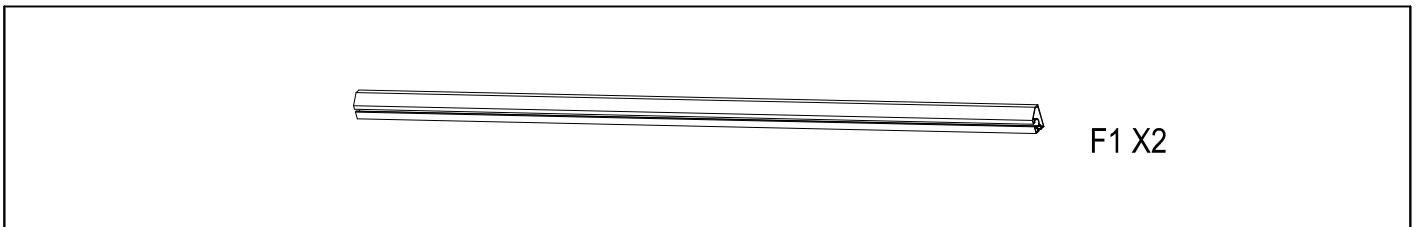
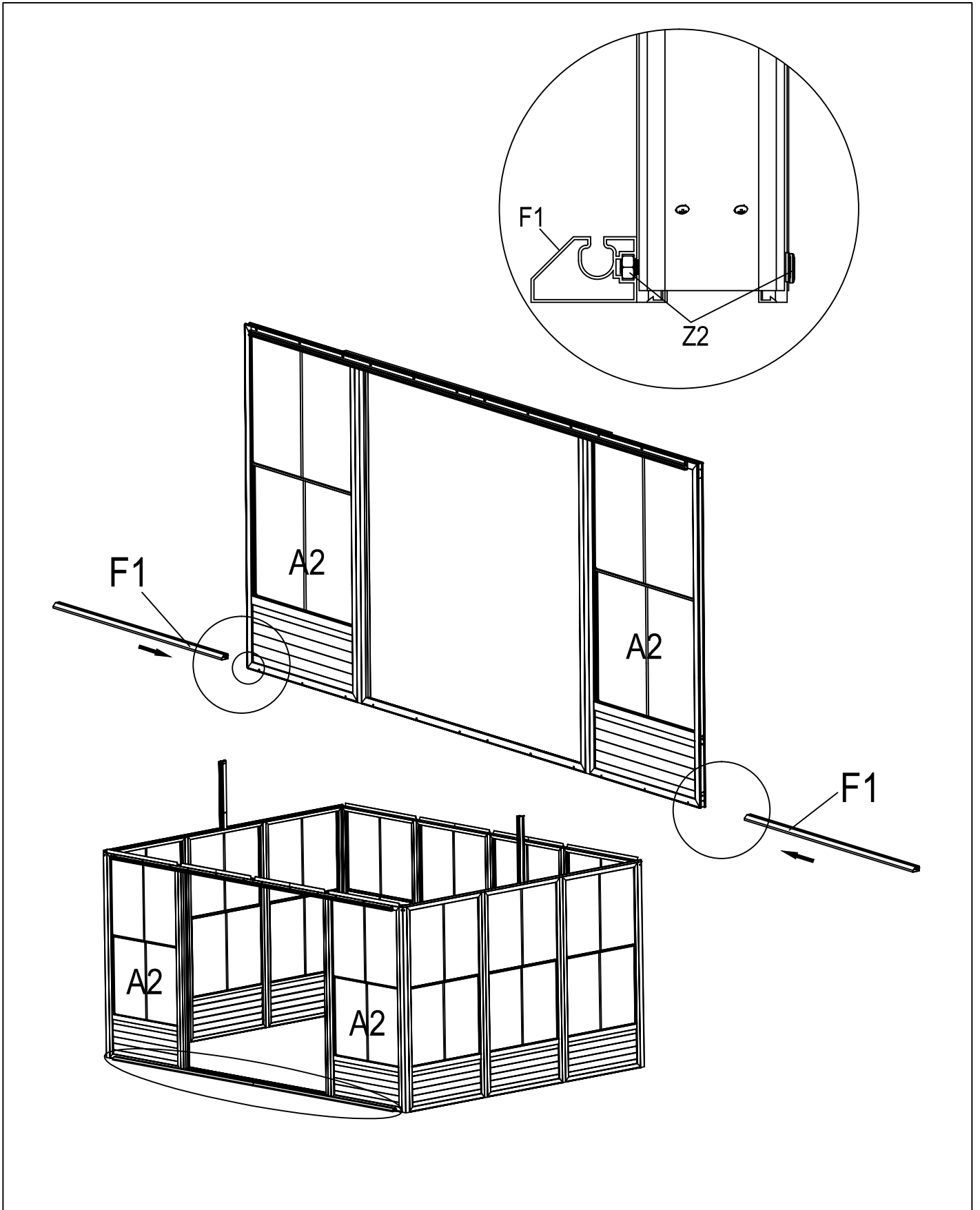

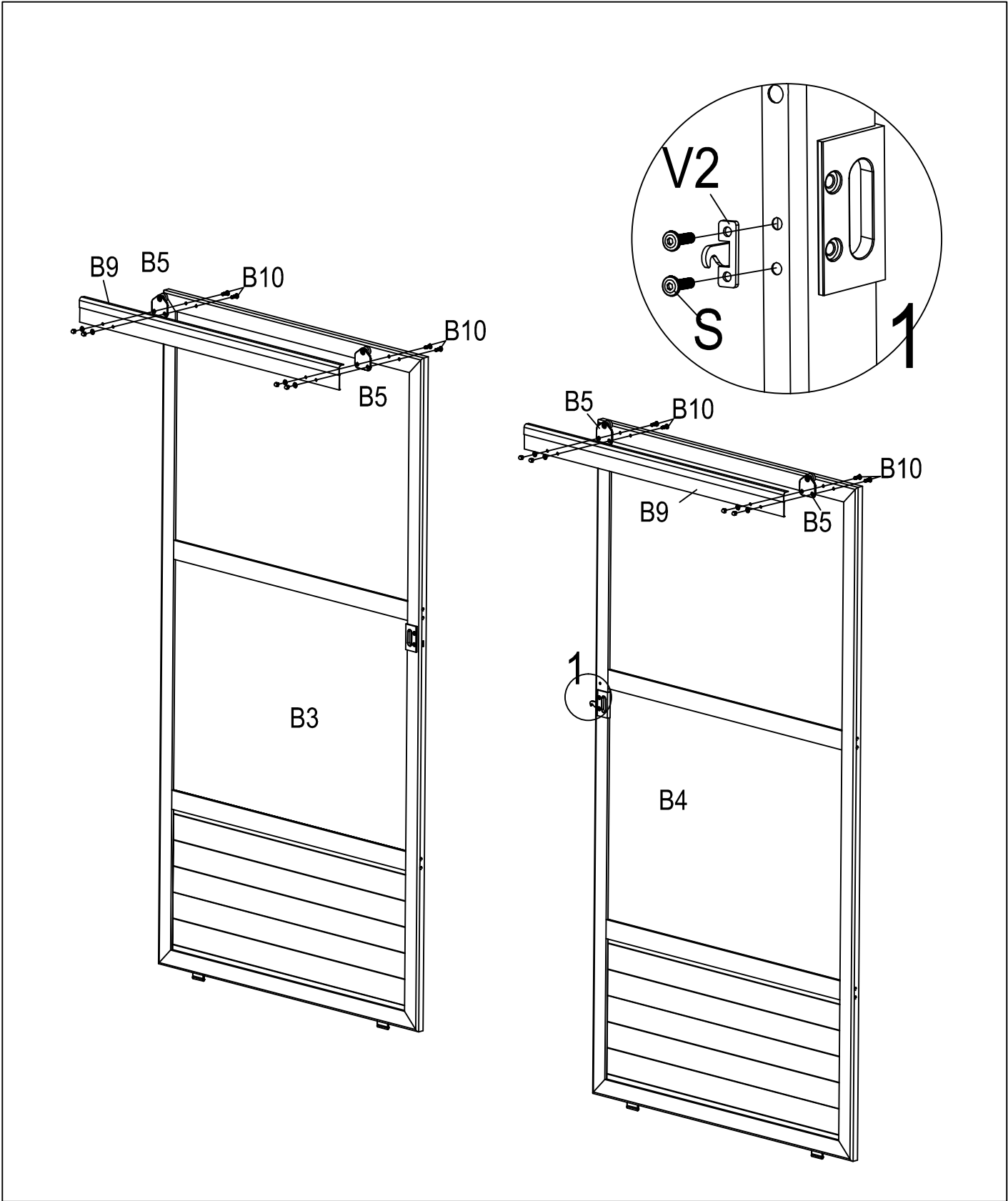
 G1 X1	 G5 X1	 Z1X4	 S6X8
 G2 X1	 G6 X1	 Z2X12	 S5x4

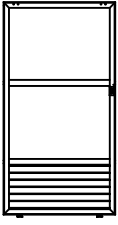
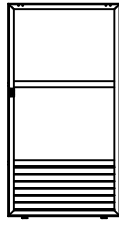

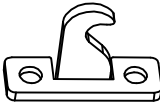
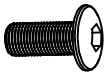

 <p>B3 X1</p>	 <p>B4 X1</p>	 <p>B9 X2</p>	 <p>B10 X8</p>	
		 <p>B5 X4</p>	 <p>V2 X1</p>	 <p>S X2</p>

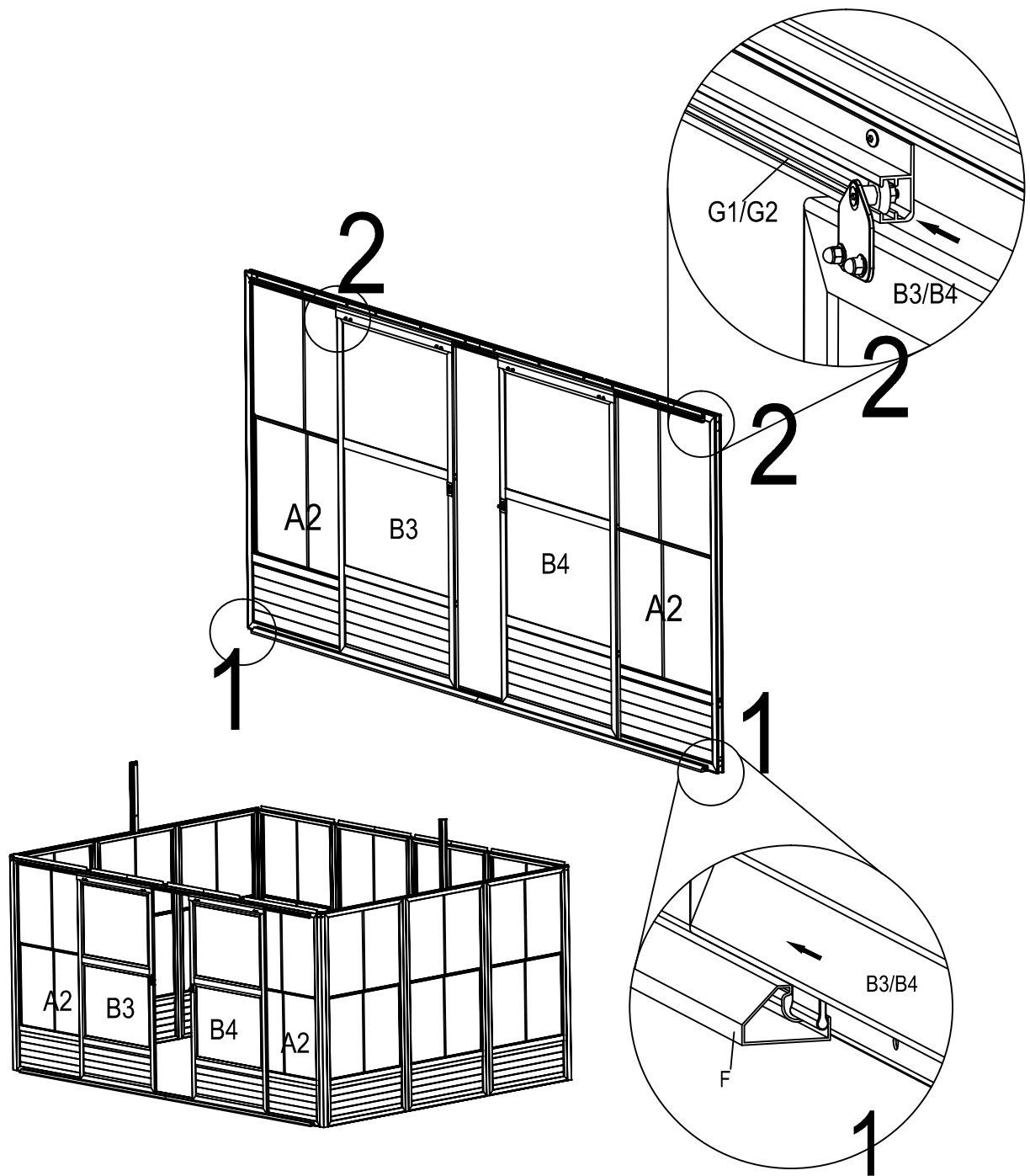

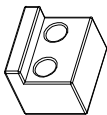
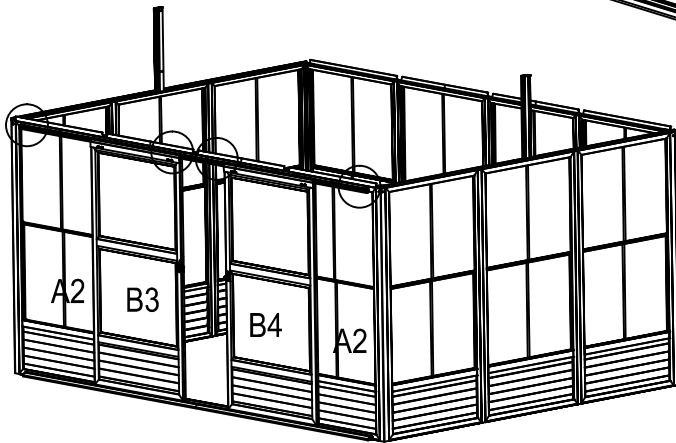
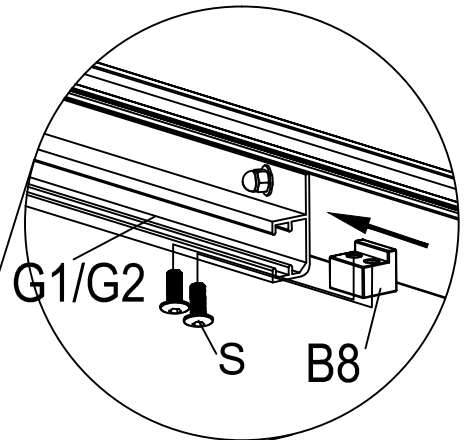
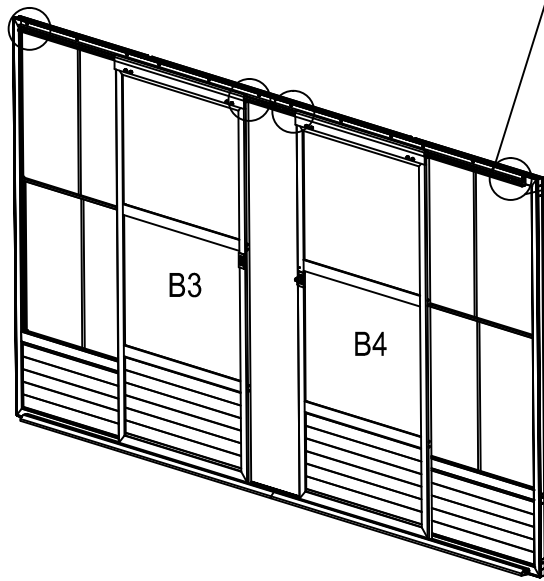

B8 X4

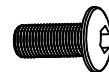

S X8

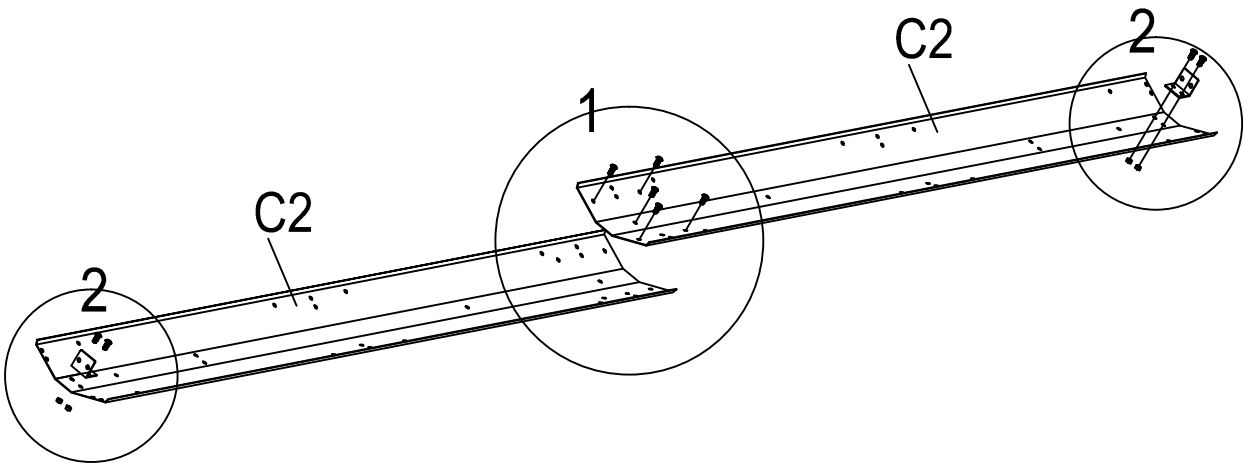
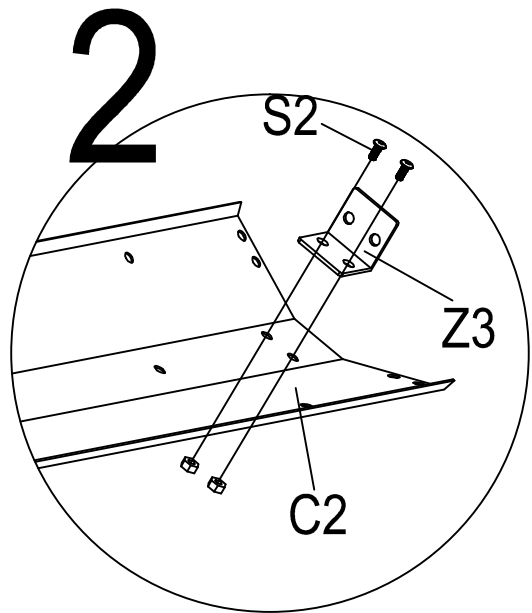
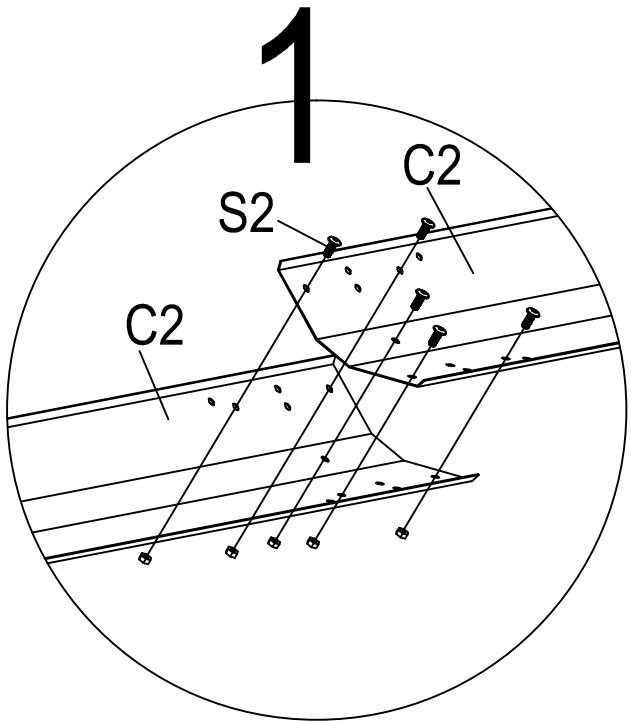

C2 X2



Z3 X2



S2 X9

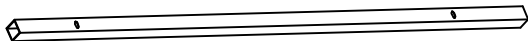
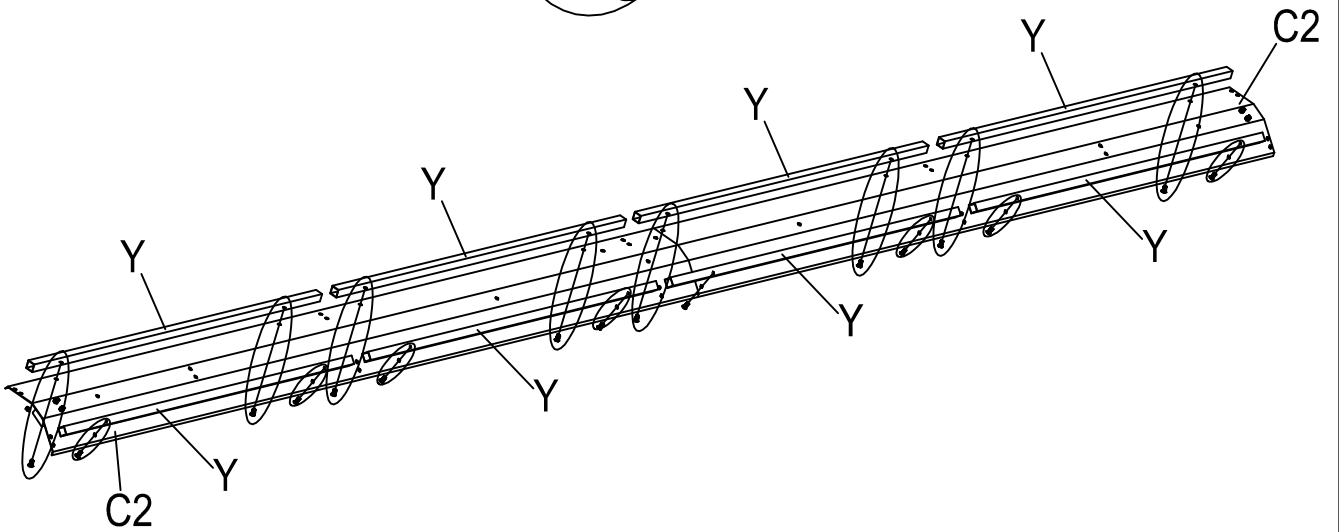
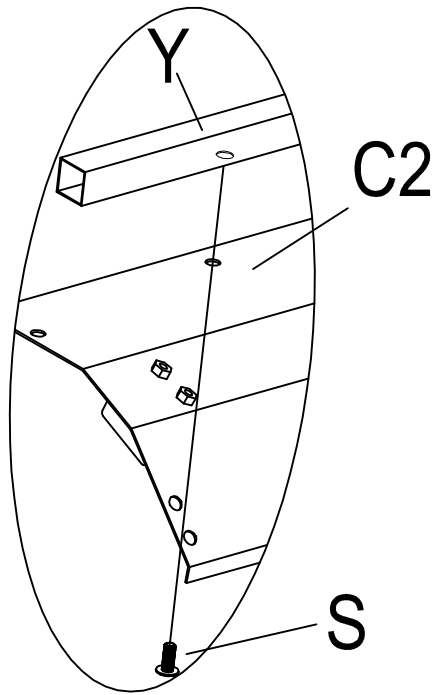

Y X8

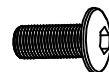



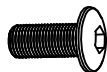
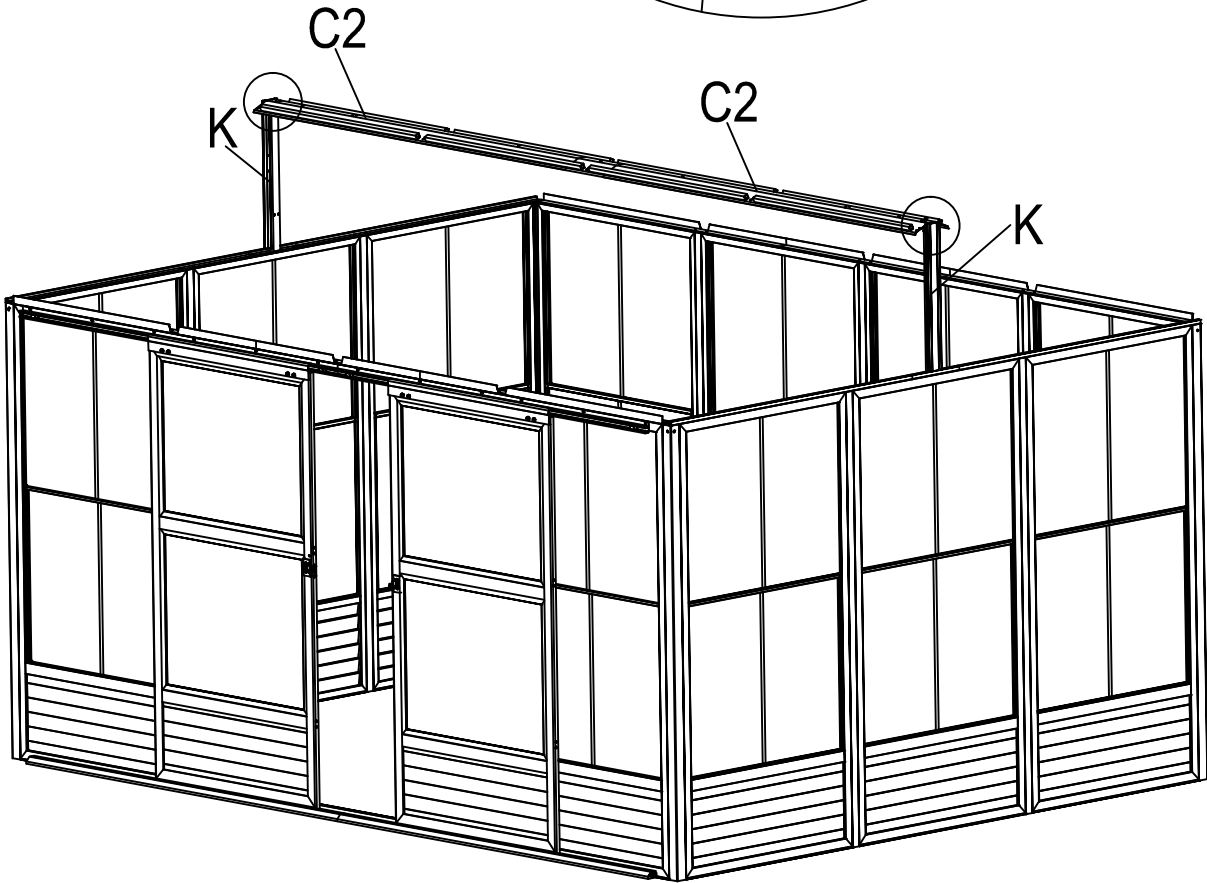
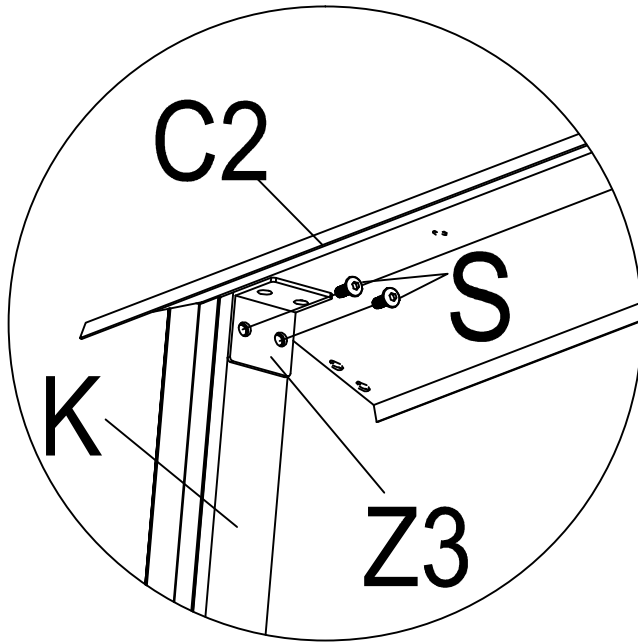

S X16

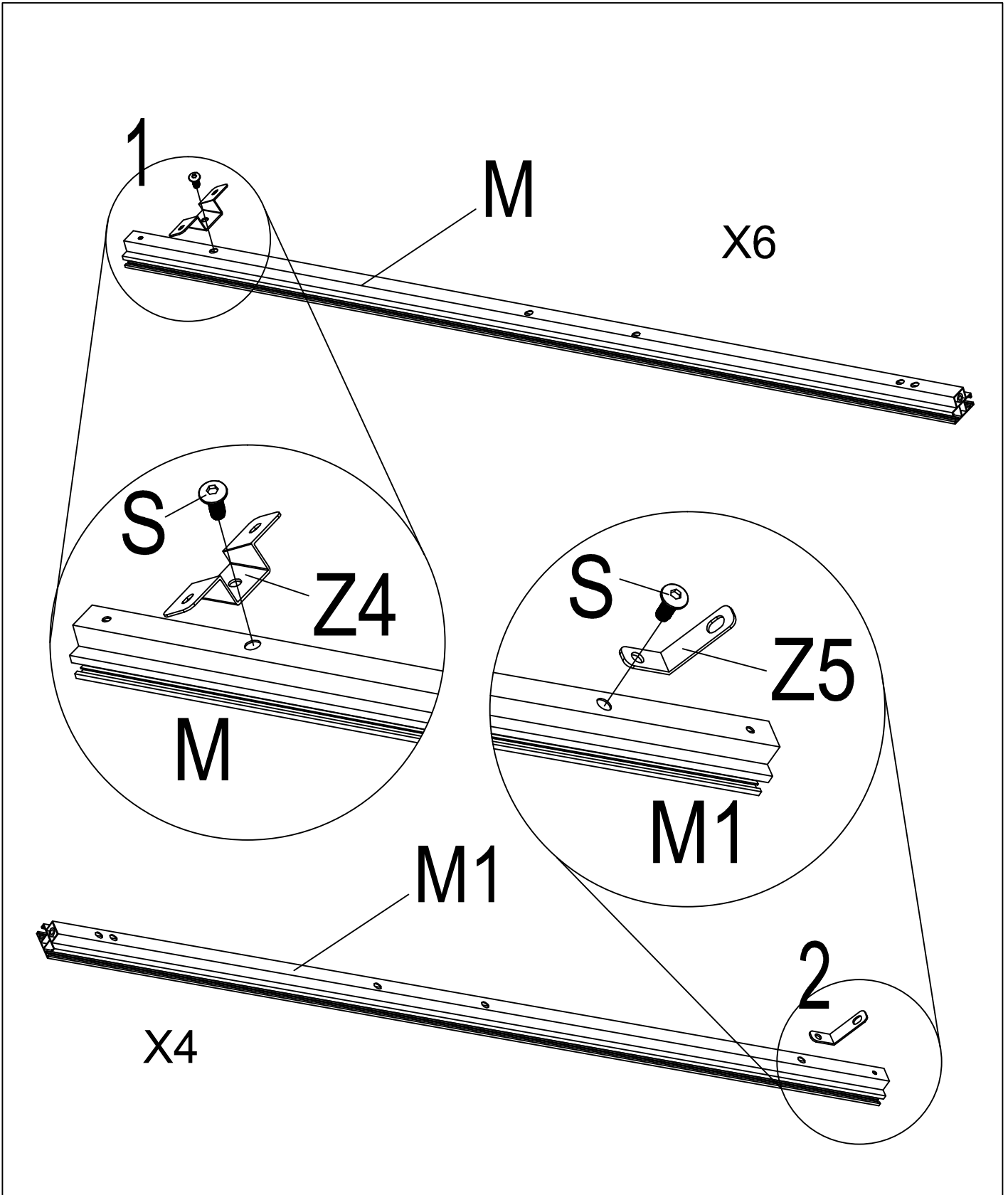

S X4

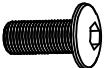

 <p>M X6</p>	 <p>Z4 X6</p>	 <p>Z5 X4</p>	 <p>S X10</p>
 <p>M1 X4</p>			

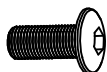
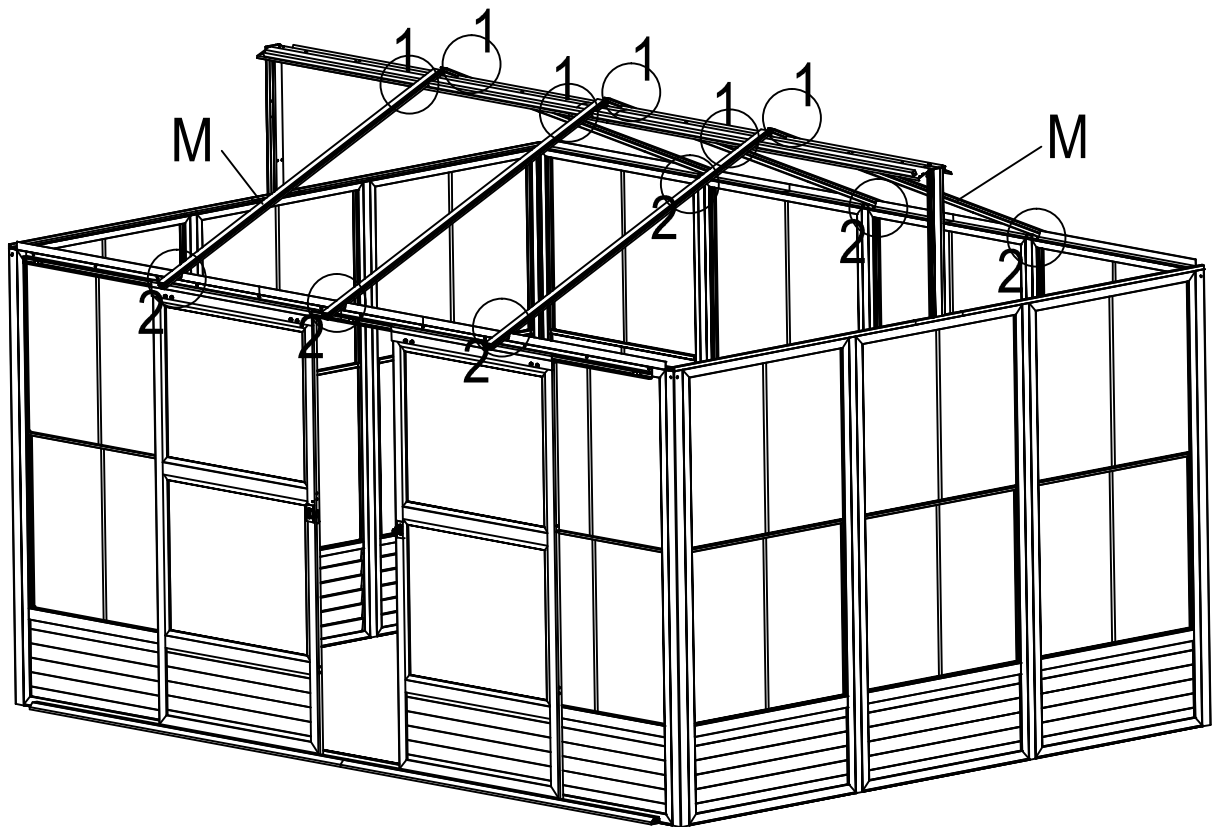
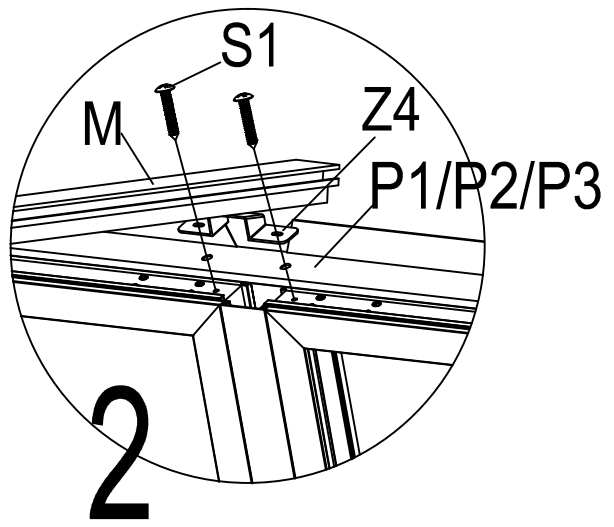
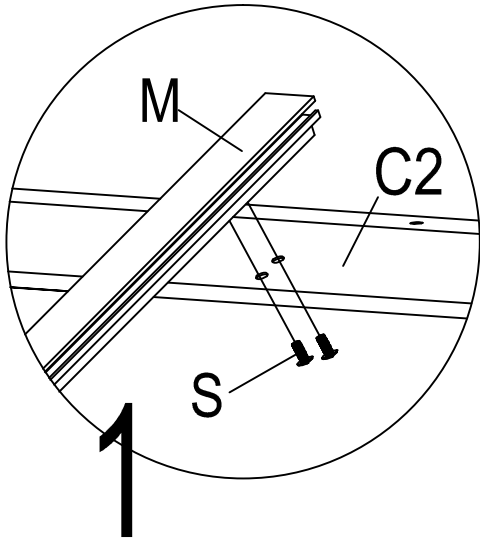

SX12



S1 X12

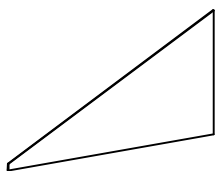
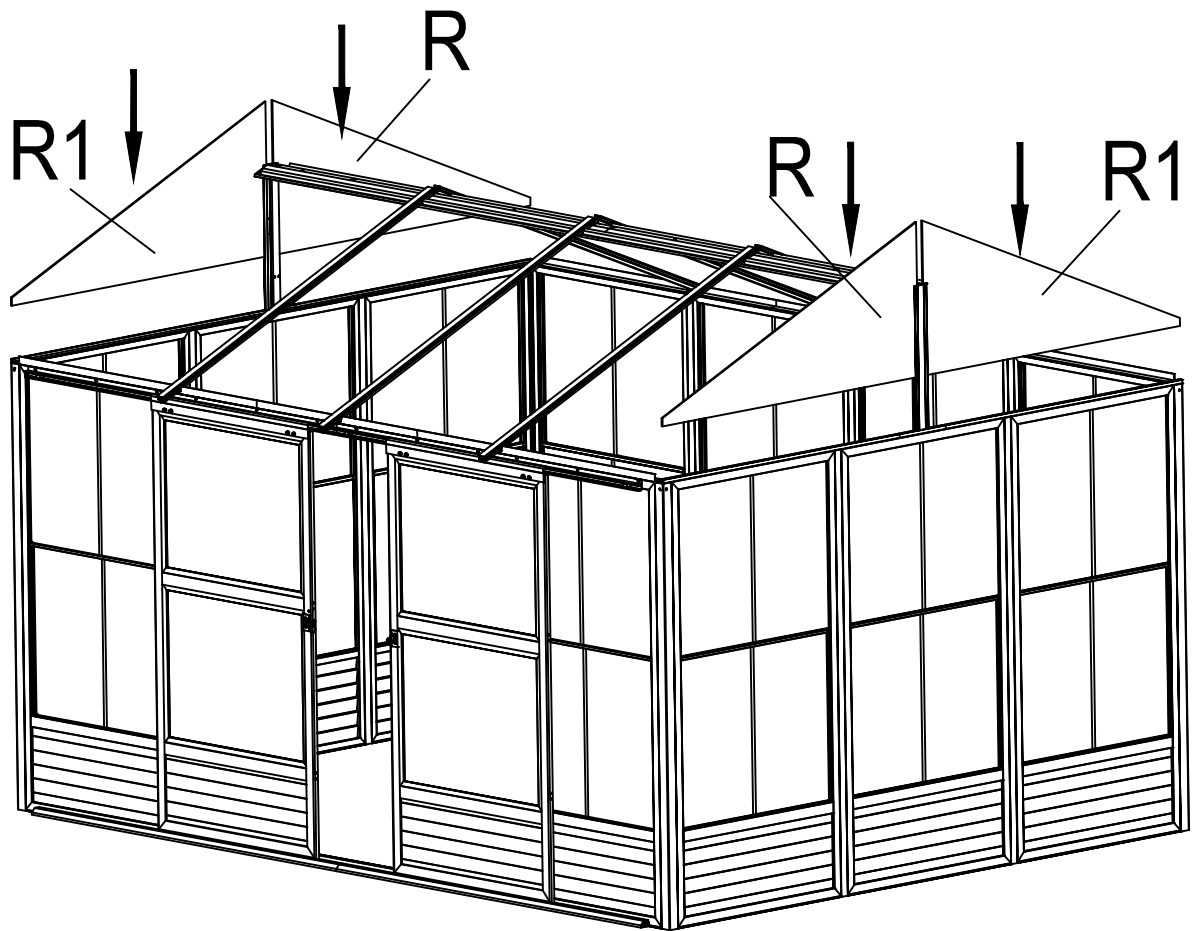
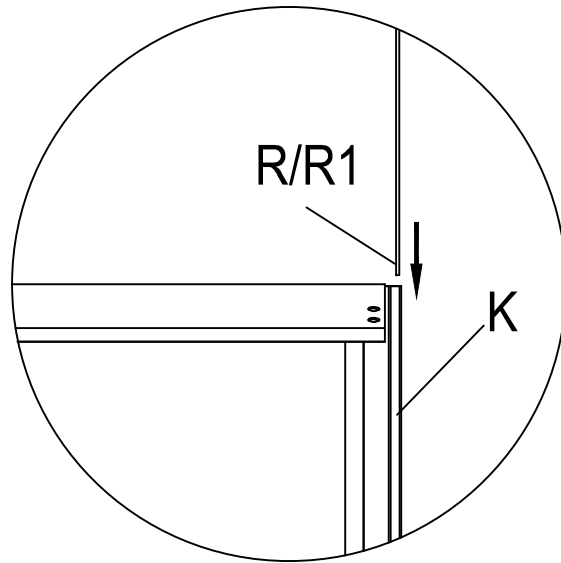

R X2

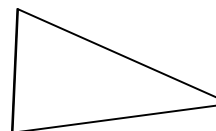

R1 X2

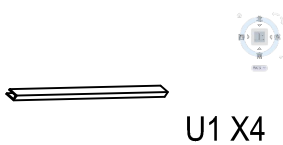
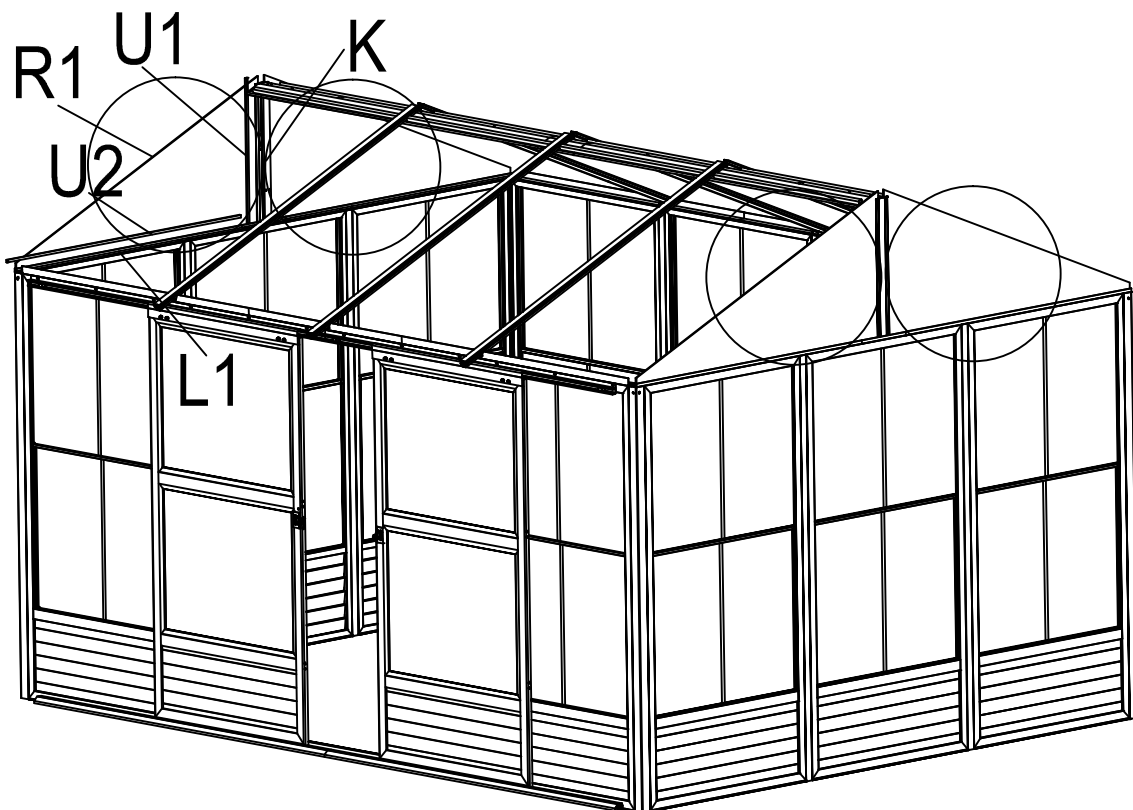
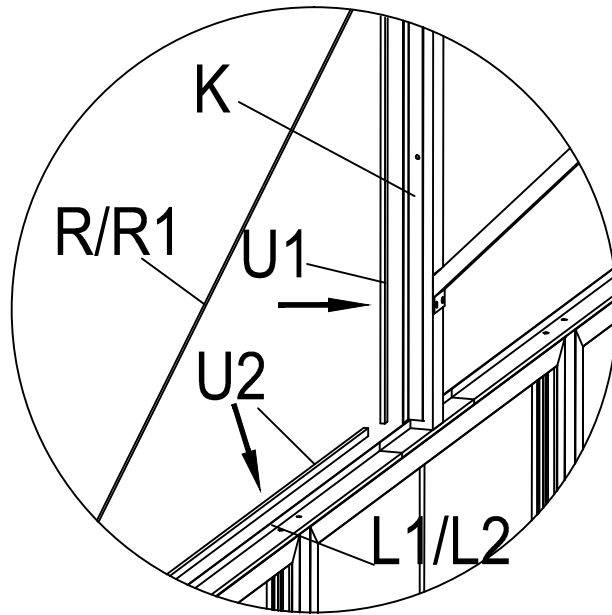

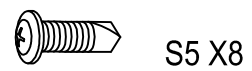
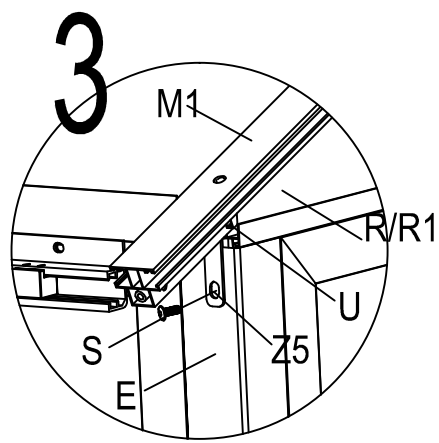
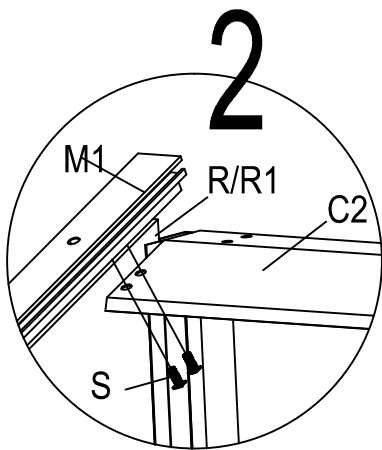
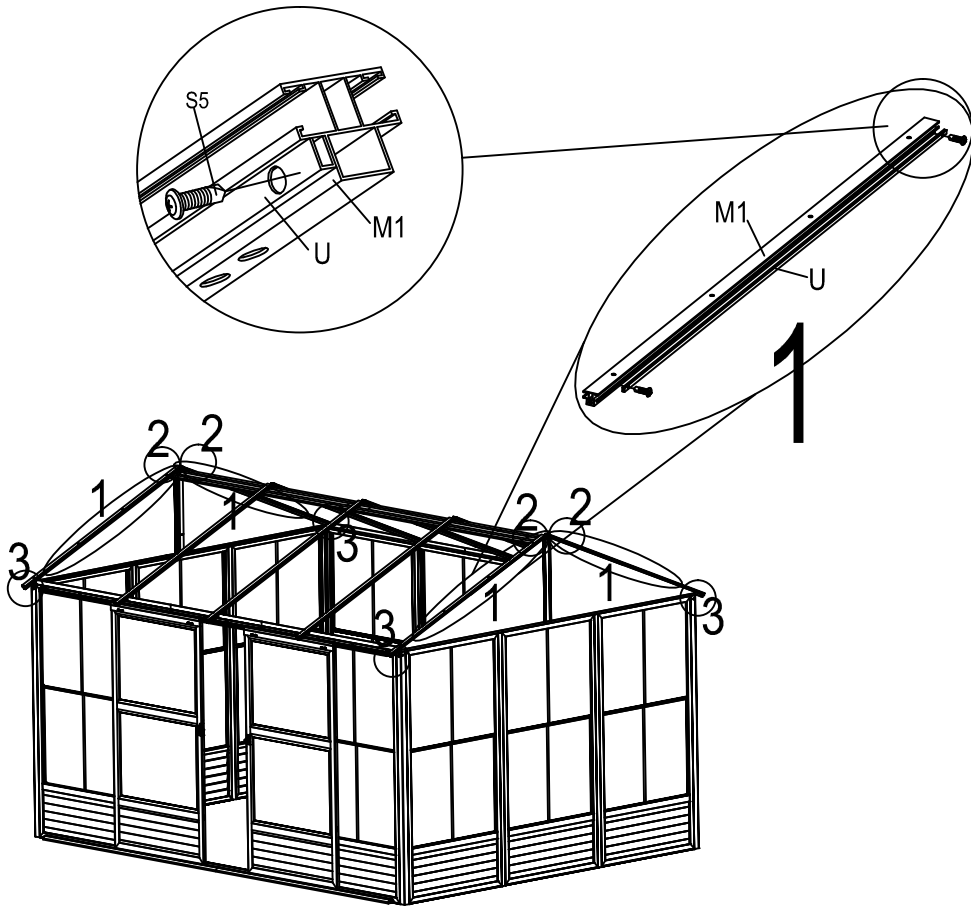

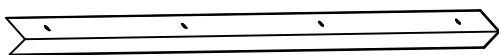
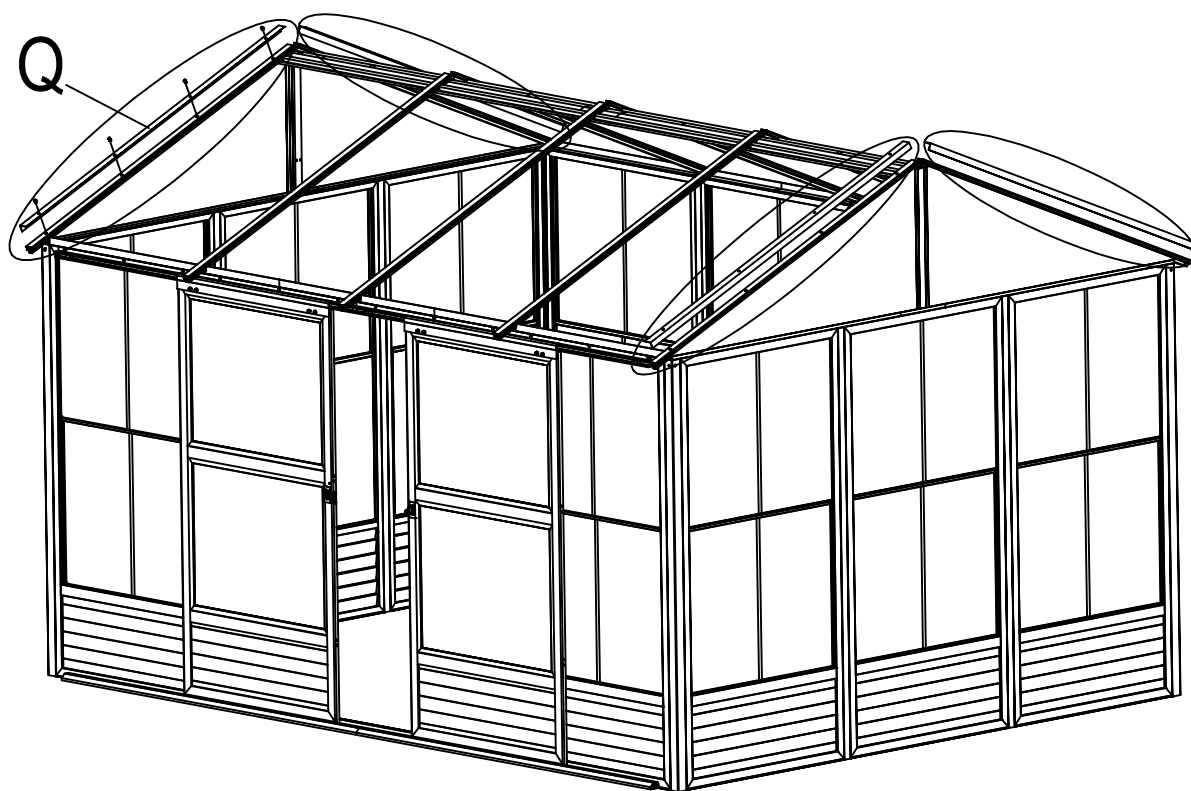
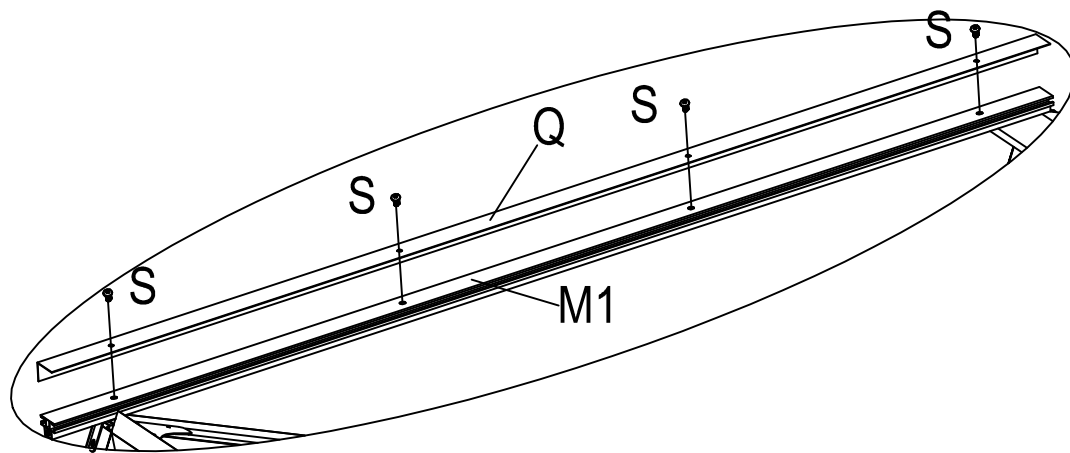

Q X4

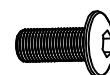

S X16

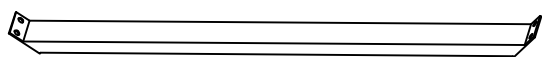
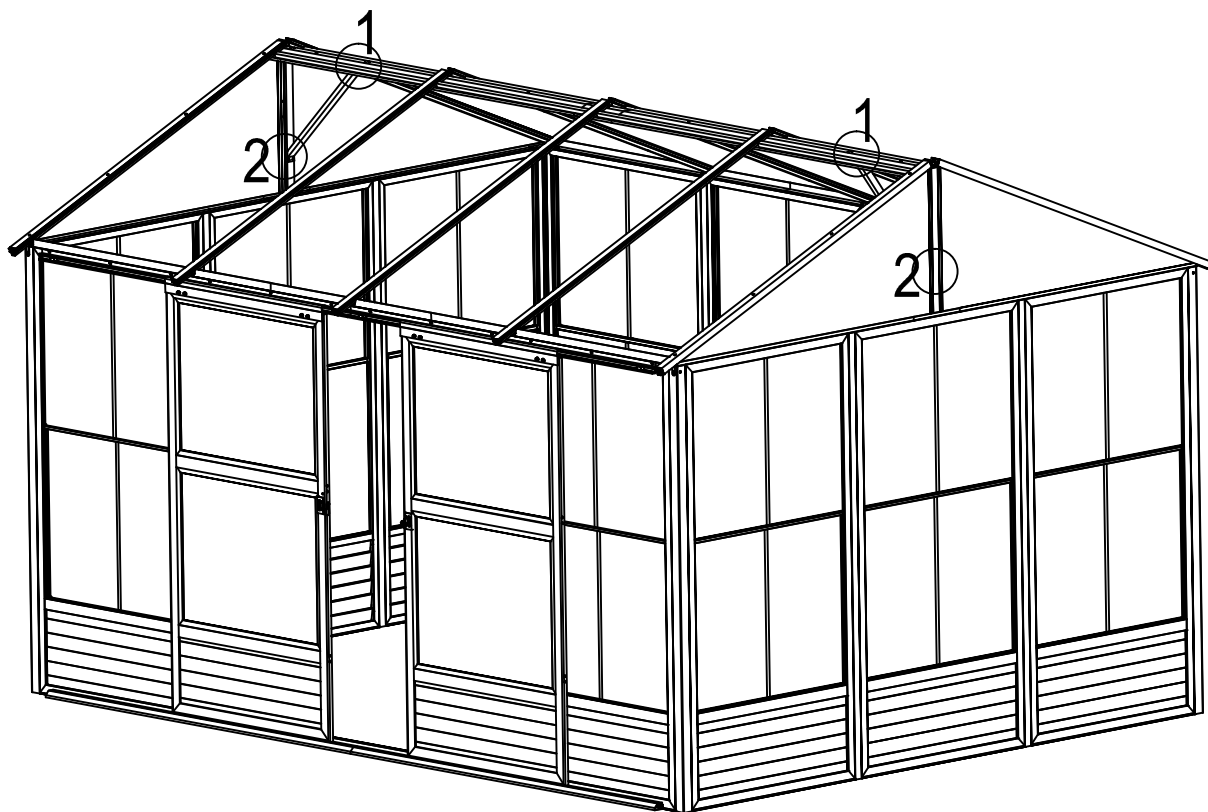
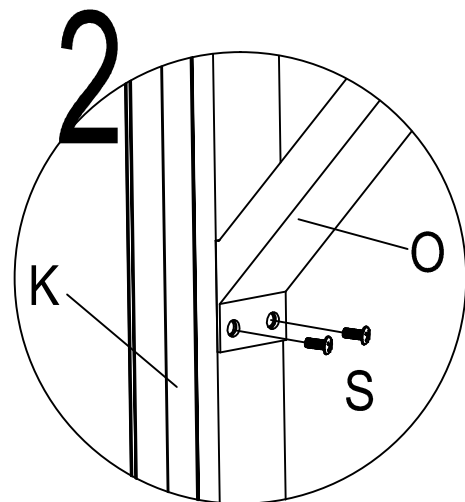
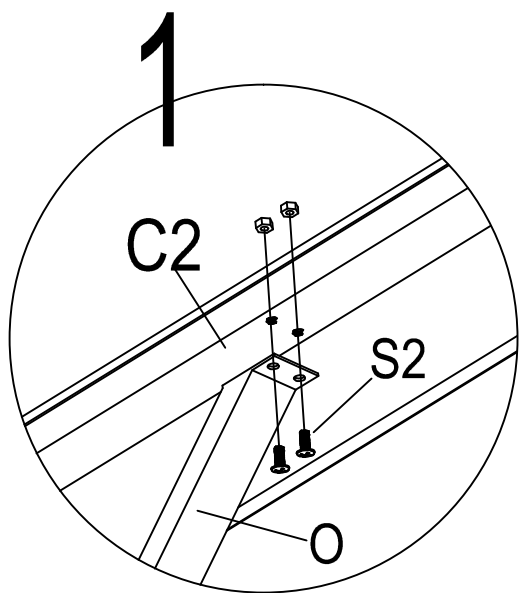

O X2

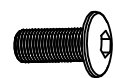

S X4



S2 X4

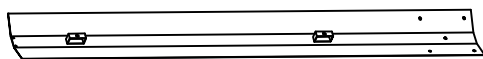
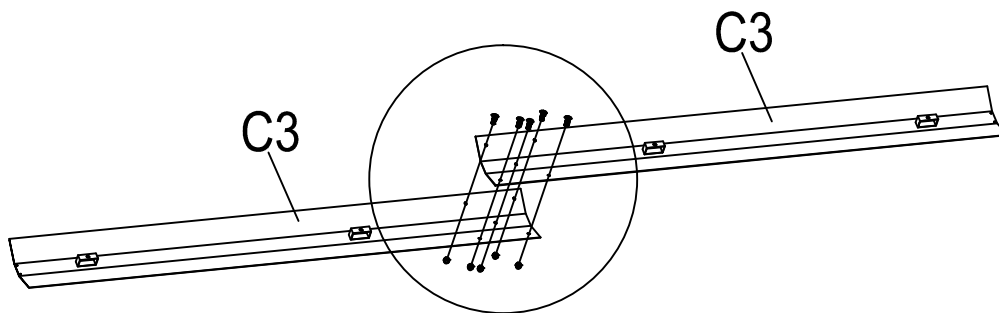
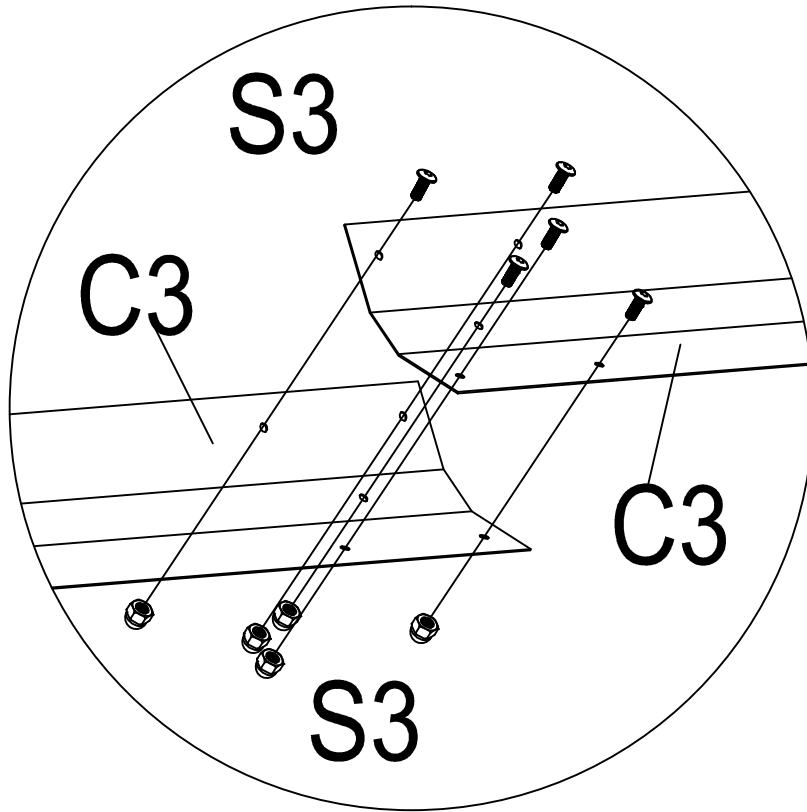

C3 X2



S3 X5

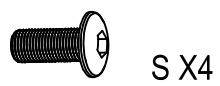
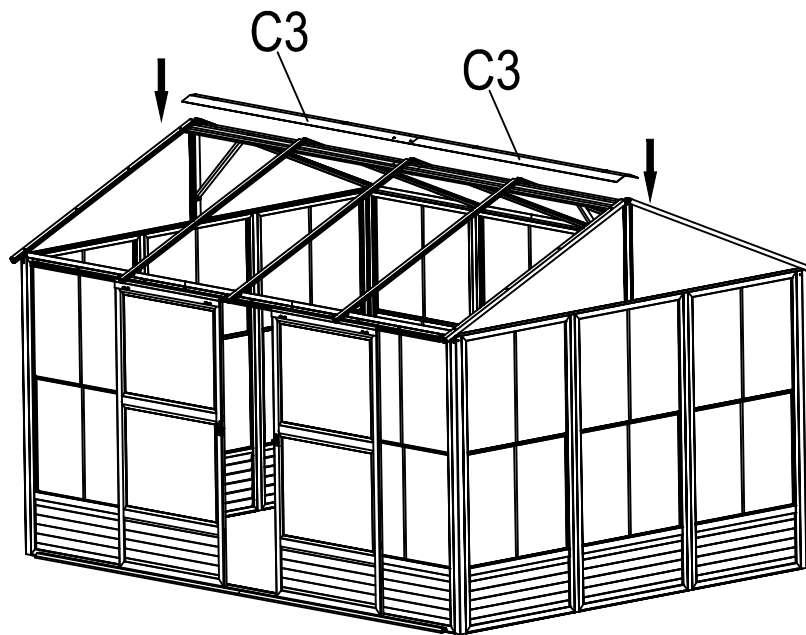
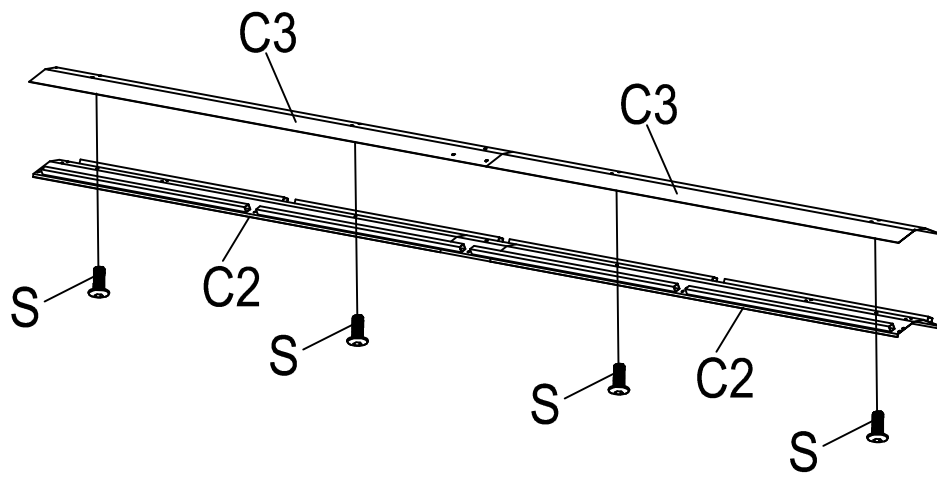

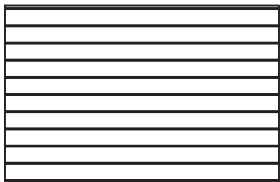
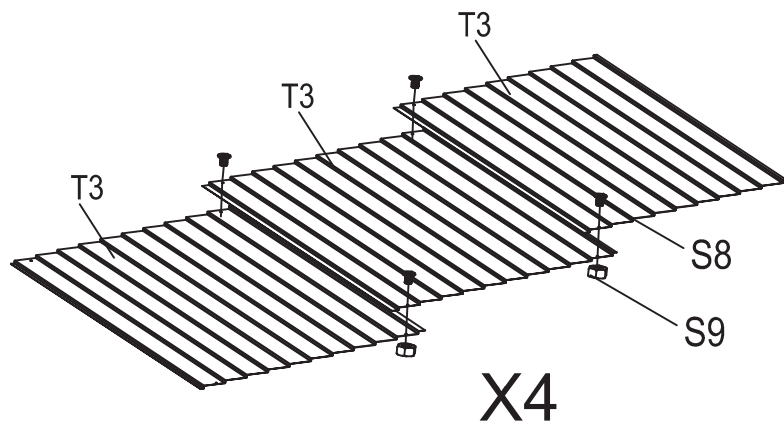
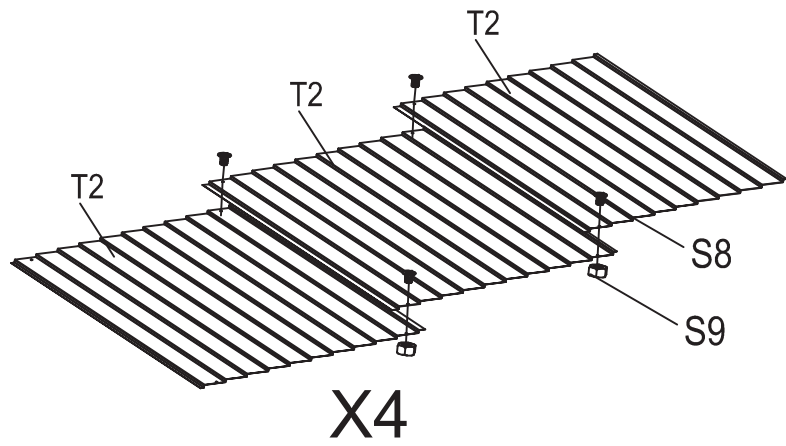

T2 X12

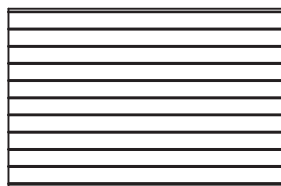

T3 X12



S8 X32



S9 X32

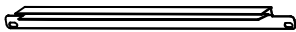
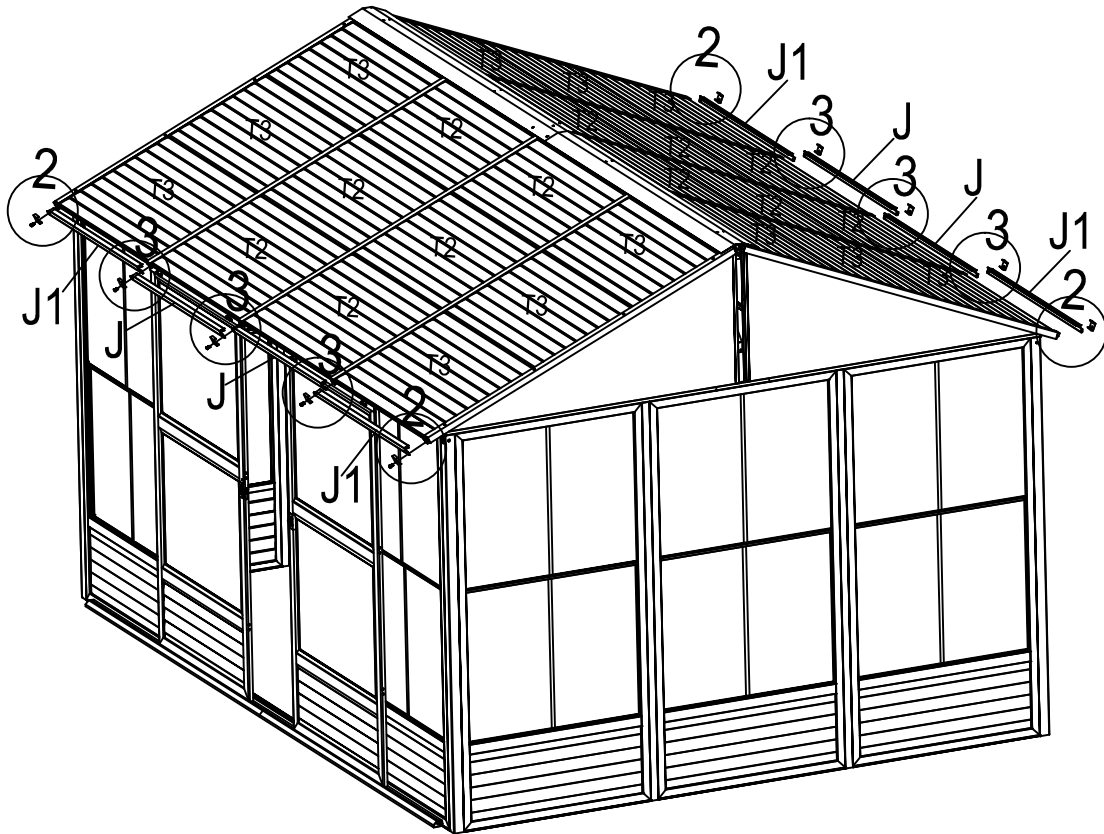
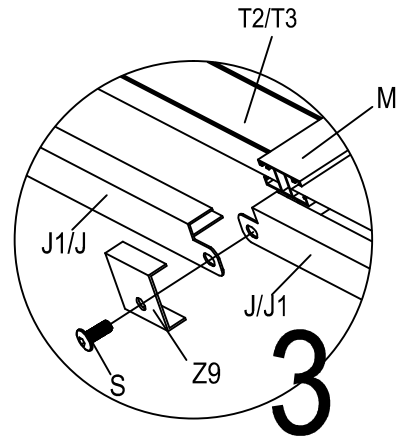
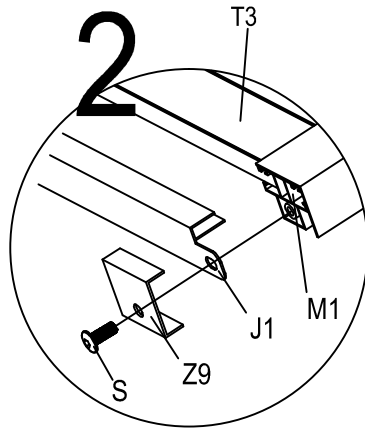
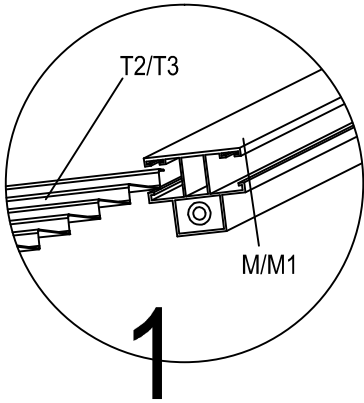

J X4

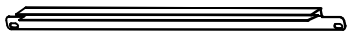

J1 X4



Z9 X10

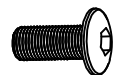

S X10

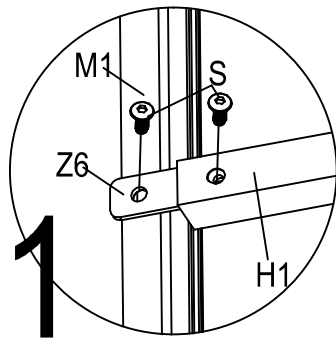

1

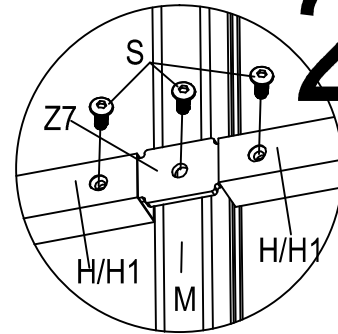

2

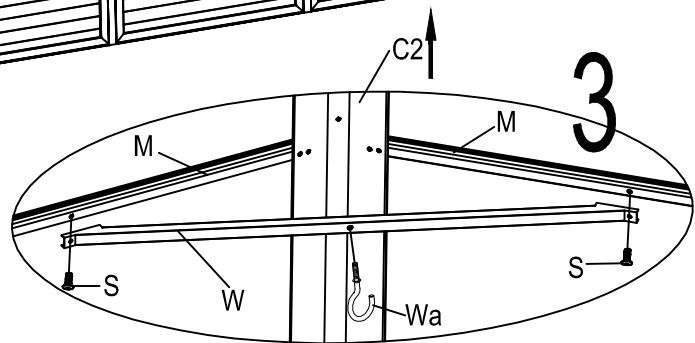
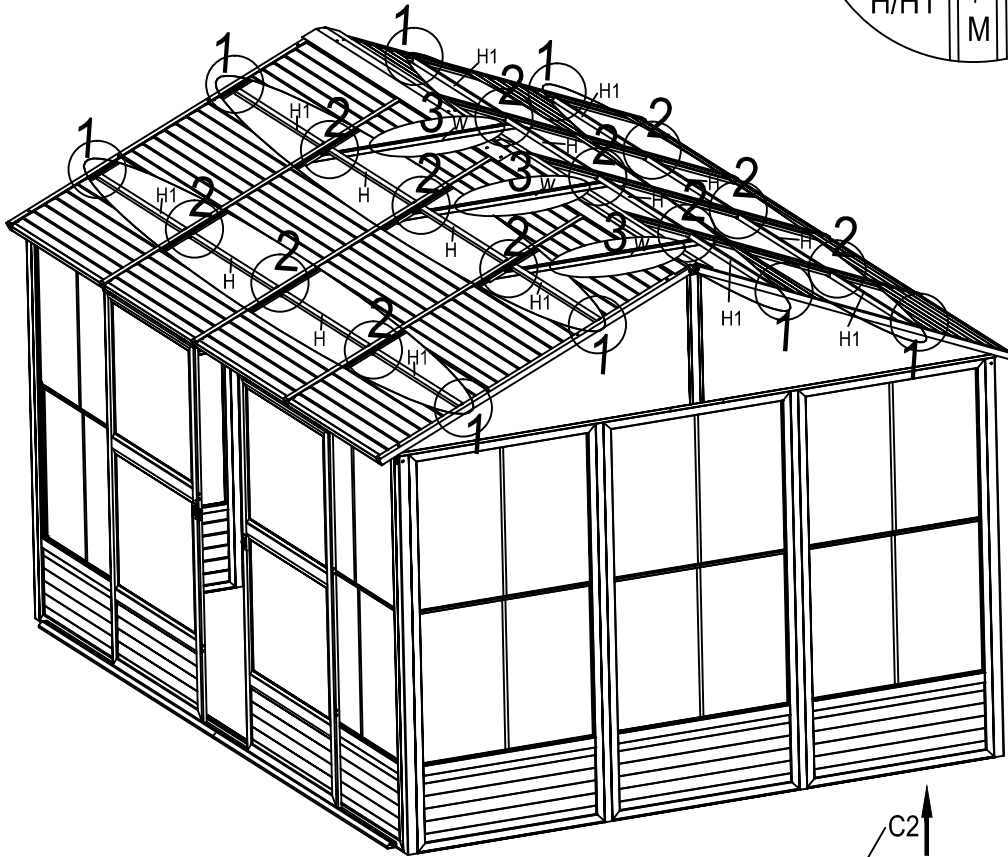

3

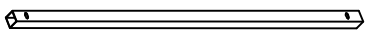

H X8

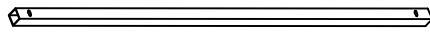

H1 X8



W X3

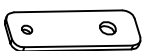

Z6 X8



Z7 X12

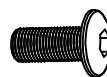

S X58

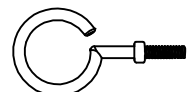

Wa X3

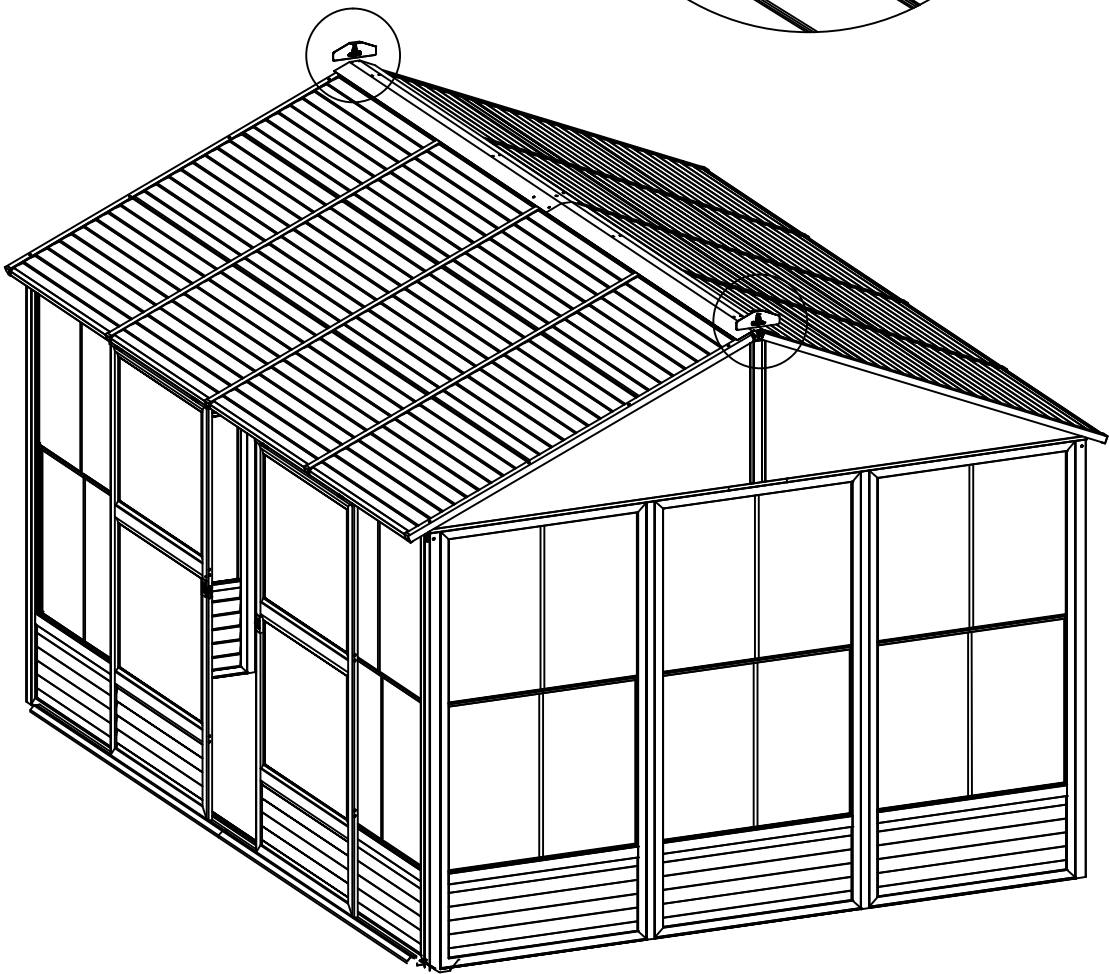
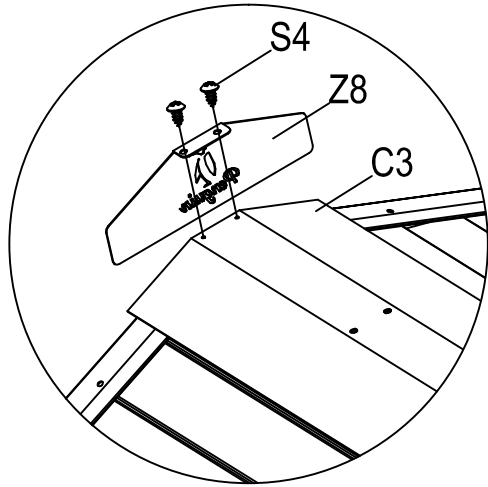

Z8 X2

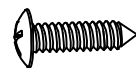

S4 X4

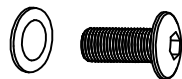
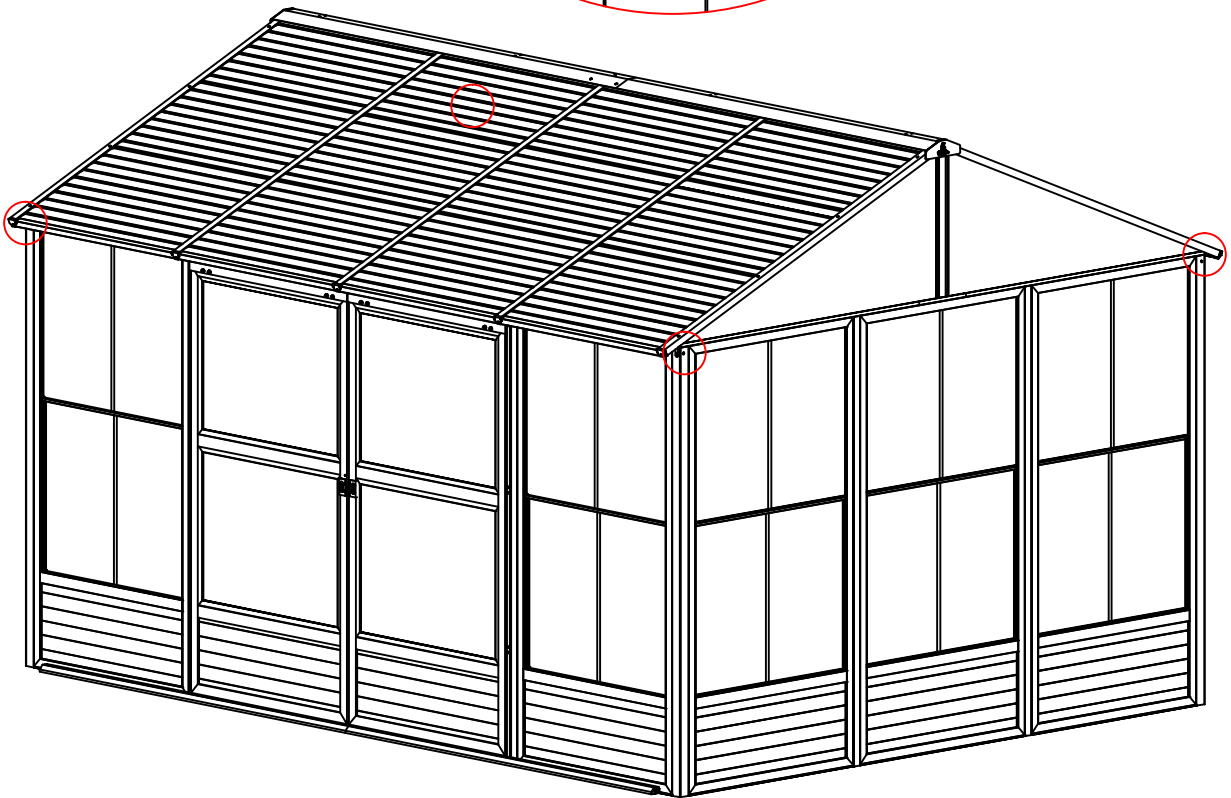
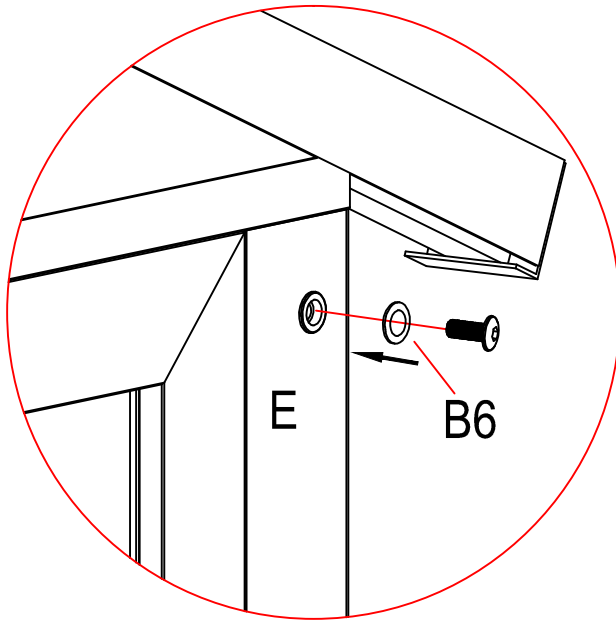

B6 X4

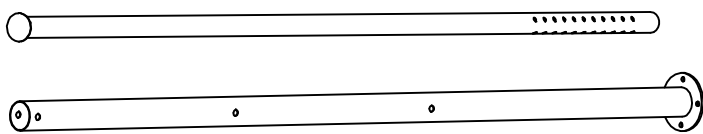
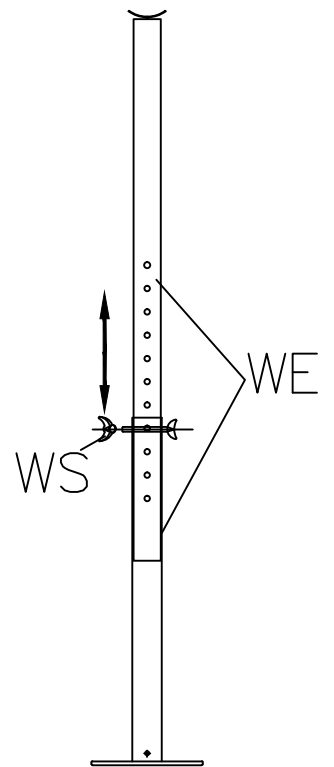
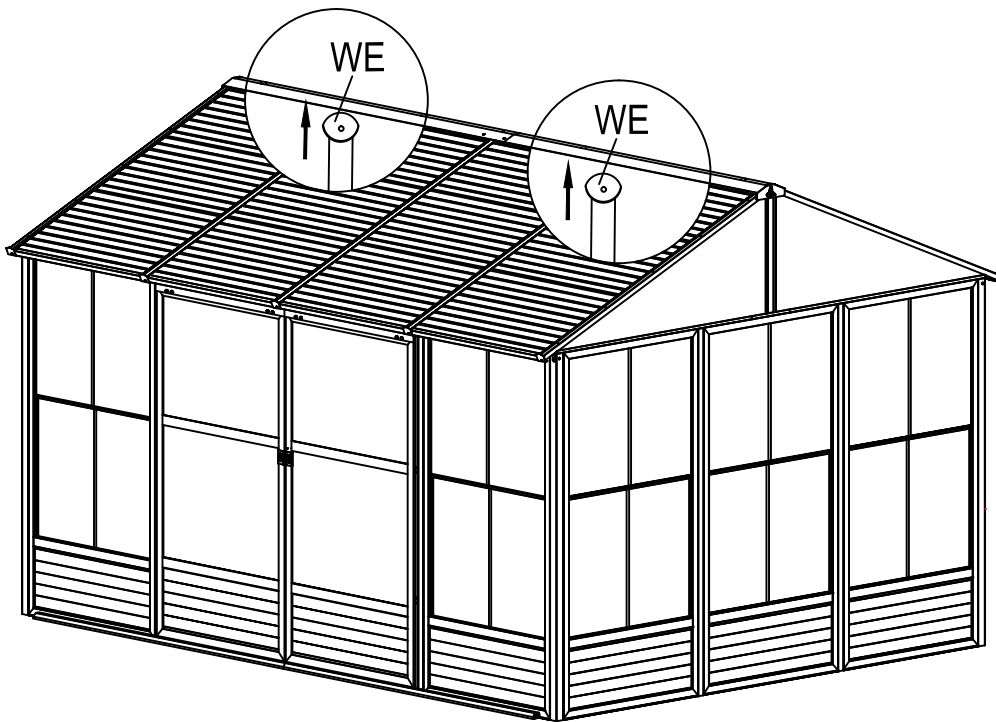

WE X2



WS X2

GARANTIE

Inspectez soigneusement le contenu de l'emballage afin de vérifier si certaines composantes sont manquantes ou endommagées. Advenant que certaines pièces soient manquantes ou endommagées, **ne retournez pas le produit à l'endroit où vous l'avez acheté**; contactez plutôt le département d'expérience client de Gazebo Penguin

Montréal : (514) 276-3485

Ailleurs au Canada et États-Unis : 1-800-737-7174

info@gazebopenguin.com

Ce produit a été conçu et fabriqué afin de répondre aux normes les plus exigeantes en matière de qualité et de durabilité.

Sous réserve de la section « limitations et exclusions à la garantie » ci-dessous, il est garanti contre les défauts matériels ou de fabrication:

- **1 AN SUR LES DÉFAUTS MANUFACTURIERS**

Advenant que le produit soit endommagé ou que la période de garantie soit expirée, veuillez contacter le département d'expérience client de Gazebo Penguin afin d'obtenir une liste complète des pièces de remplacement et des prix.

LIMITATIONS ET EXCLUSIONS À LA GARANTIE

- 1. Dommages non couverts:** Cette garantie ne couvre pas les dommages causés par le vent, la chute d'objets, le feu, les animaux, la végétation, le vandalisme, les conditions climatiques extrêmes, ni les effondrements dus à l'accumulation de neige et de glace.
- 2. Entretien du toit:** Le toit doit rester libre de toute accumulation de neige ou de glace. Ces accumulations doivent être retirées en sections de cinq pieds (5) à la fois, de droite à gauche. Les dommages causés par un défaut d'entretien du toit ne sont pas couverts par la garantie.
- 3. Retrait de neige et de glace:** Le retrait de neige ou de glace depuis l'intérieur du produit est interdit, car il peut causer des dommages au produit.
- 4. Positionnement:** Il est déconseillé de placer le produit à proximité d'immeubles ou d'arbres, car la neige ou la glace peut glisser et s'accumuler sur le toit, provoquant un poids excessif.
- 5. Installation:** La garantie est valide uniquement si le produit est installé conformément aux instructions fournies par Gazebo Penguin. Une installation incorrecte, notamment un ancrage inadéquat, annule la garantie.
- 6. Infiltration d'eau:** Des infiltrations d'eau peuvent survenir en cas de fortes pluies. Consultez le manuel d'instructions pour les positions des fenêtres et les informations sur l'évacuation de l'eau.
- 7. Clause de remplacement:** Nous nous réservons le droit de réparer ou remplacer tout produit ou pièce défectueuse, à notre seule discrétion.
- 8. Modifications:** Toute modification ou ajout au produit annule la garantie.

WARRANTY

Carefully inspect the contents of the package to check if any components are missing or damaged. In the event that any parts are missing or damaged, **do not return the product to the place of purchase; instead, contact Gazebo Penguin's Customer Experience Department.**

Montreal: (514) 276-3485

Elsewhere in Canada and the United States: 1-800-737-7174

info@gazebopenguin.com

This product has been designed and manufactured to meet the highest standards of quality and durability. It is warranted against defects in material and/or workmanship as subjected in the «Warranty Limitations and exclusions» listed below:

- **1 YEAR ON MANUFACTURING DEFECTS**

In the event that the product is damaged or the warranty period has expired, please contact Gazebo Penguin's Customer Experience Department for a complete list of replacement parts and prices.

WARRANTY LIMITATIONS AND EXCLUSIONS

- 1. Uncovered Damages:** This warranty does not cover damages caused by wind, falling objects, fire, animals, vegetation, vandalism, extreme weather conditions, or collapses due to the accumulation of snow and/or ice.
- 2. Roof Maintenance:** The roof must remain free of snow and ice accumulation. Such accumulation must be removed in five-foot (5') sections from right to left. Damages resulting from lack of roof maintenance are not covered under the warranty.
- 3. Snow and Ice Removal:** Removing snow or ice from inside the product is prohibited, as it may damage the product.
- 4. Positioning:** It is advised not to place the product near buildings or trees, as snow and/or ice may slide off and accumulate on the roof, causing excessive weight.
- 5. Installation:** The warranty is valid only if the product is installed according to the instructions provided by Gazebo Penguin. Improper installation, including inadequate anchoring, voids the warranty..
- 6. Water Infiltration:** Water infiltration may occur during heavy rains. Refer to the instruction manual for window positioning and information on water drainage.
- 7. Replacement Clause:** We reserve the right to repair or replace any defective product or part at our sole discretion.
- 8. Modifications:** Any modification or addition to the product voids the warranty.